

Complete Installation Guide

Open Area Sensor version OALR



Contents

01 – In the Box

02 – Hardware

03 – Power

04 – Networking

05 – Install Height & Considerations

06 – Mount Plate Installation

07 – Alternate Mounting Options

In the Box

01

Product

- + Density Open Area sensor
- + QR code for Quick Start Guide
- + Legal information booklet

Ceiling mount kit

- + Mount plate

Sensors

60-64GHz mmWave sensor

Environmental specifications

- + Temperature: 32°- 95°F (0°- 35°C)
- + Relative humidity: 20% to 80%
- + non-condensing
- + Rated for indoor installation only

Note: Open Area sensors can reach temperatures up to 135°F (57°C) after going online. Please keep proper ventilation in mind. If you need to handle the sensor, unplug it and wait a few minutes for it to cool down, or wear gloves so it is more comfortable to handle the device.

Indicators

Multi-color status LED

Unit weight

0.78lbs (0.35kg)

Dimensions & features

- + White polycarbonate enclosure
- + Powder coated aluminum base
- + Integrated 1/4"-20 mounting threads
- + Thread depth: 0.2in (0.5cm)
- + Mount plate

Interface

- + 1x 10/100/1000 BaseT RJ45 interface
- + WiFi/Bluetooth dongle
- + Reset button

Mounting Plate

- A. Ceiling or Drop Ceiling Tile
- B. 4" Square Junction Box (US)
- C. 4" Round Junction Box (US)
- D. 3.5" Round Junction Box (US)
- E. Single-Gang Outlet Box (US)
- F. Pass Through
- G. Auxiliary Hole
- H. 1/4"-20 Threaded Stud

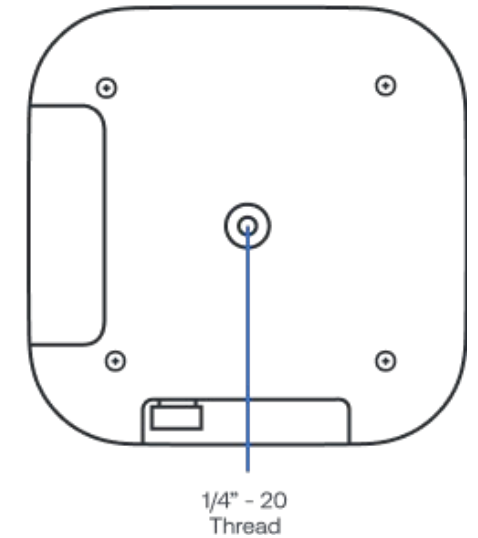
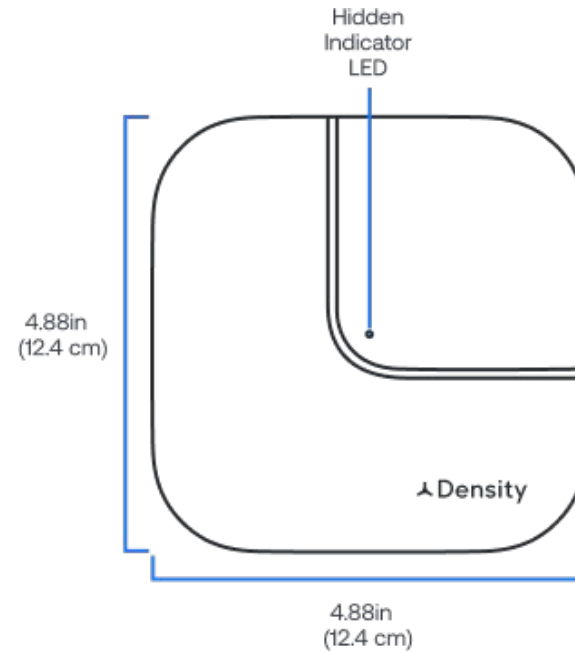
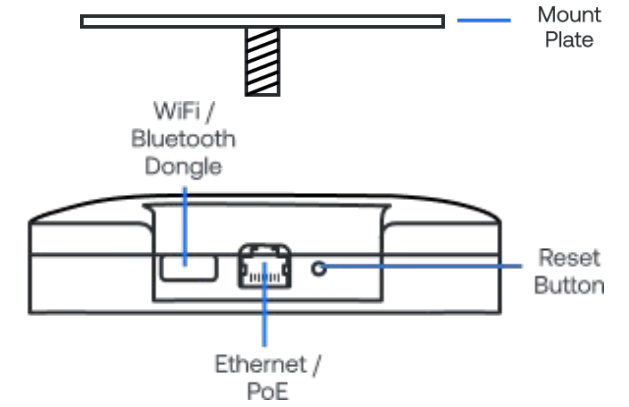
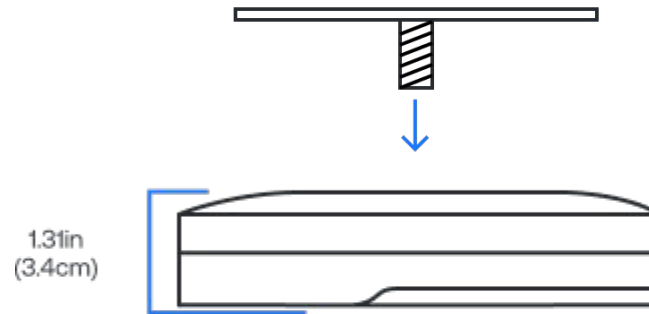
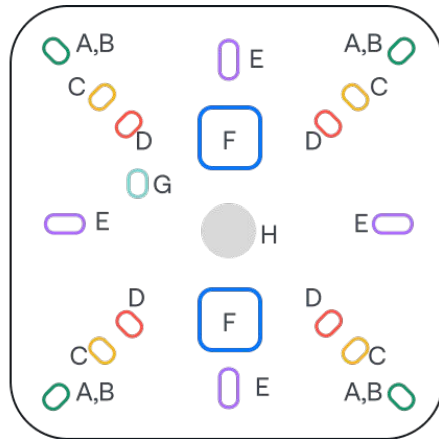

Resetting the sensor

To reset the sensor to default factory settings, press and hold the reset button until the LED stops blinking (approx 10 seconds). The sensor must be plugged in and connected to power in order to reset.

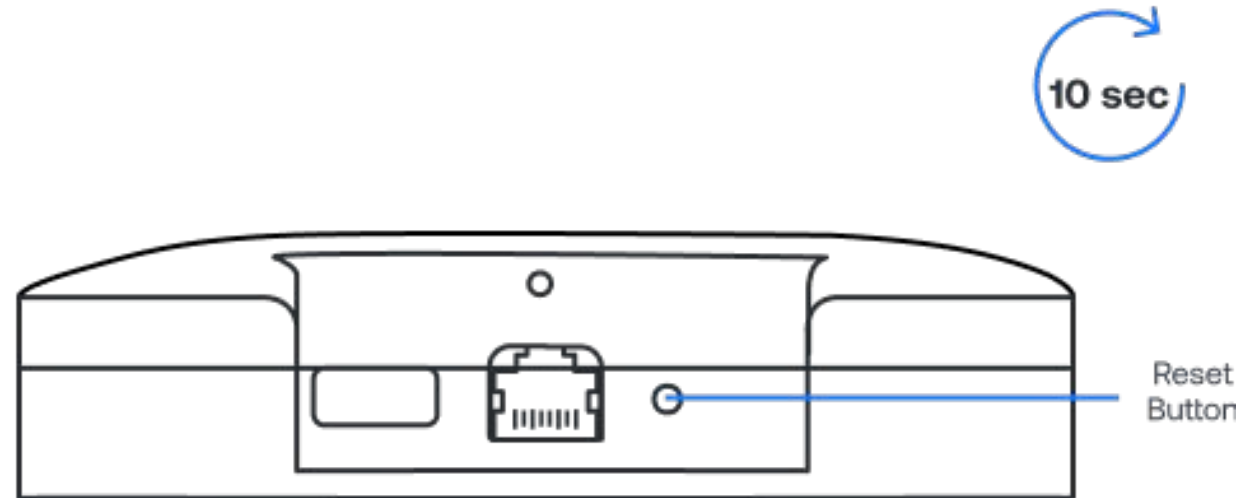

Power requirements

The Open Area sensor can be powered by either a 802.3af PoE switch or a PoE Injector Wall Plug.



Cable requirements

The sensor requires a Cat 5e or later ethernet cable (not included). Flat white cable recommended for optimal aesthetics.

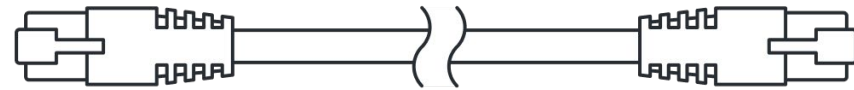

Cat 5e or later

Networking basics

Density devices require internet connectivity to pass data to the web application.

Recommended Configuration: Wired ethernet connectivity configured via DHCP with internal NTP and internal DNS servers. IPv4 is required.

Networks that are not supported:

- + Captive portal
- + Proxy
- + WPA2 Enterprise
- + Hidden Networks *
- + 5GHz WiFi networks

* Hidden networks can be used if temporarily made transparent while we configure the devices.

If you have a corporate firewall

You will need to safelist the device MAC addresses (the MAC addresses can be found on the outside of the packaging box for the device). You may also have to safelist the following addresses to ensure the device is able to communicate outside of your corporate network:

- + *.density.io (port 443)
- + *.amazonaws.com
- + *.gstatic.com
- + *connman.net
- + ntp port (port 123) must be open
- + If internal DNS is not available then external DNS servers 8.8.8.8 and 8.8.4.4 will be used and port 53 must be open

Density does not currently support IP address safelisting. A list of exact API subdomains is available by request.

Density does not currently support IP address whitelisting. A list of exact API subdomains is available by request.

- + Internal NTP server is strongly recommended. If not available, port 123 must be open to the internet.
- + An Internal DNS server is strongly recommended. If one is not available, access to the internet on port 53 is required.

Sensor LED status indicator

The sensor has an indicator LED located on the front of the sensor. The color chart below explains the meaning of each color, defines any issues, and lists what actions to take if necessary.

If the recommended action does not resolve the LED light error status, factory reset the sensor. To reset, press and hold the reset button on the side of the sensor until the LED light starts flashing white. If the issue persists, please reach out to support@density.io

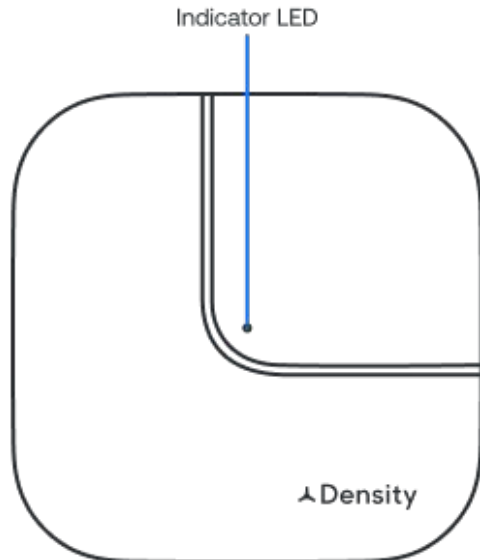

Color	Pattern	Visual	Meaning	Description/Action
No Light	No Light	•	Sensor is not receiving power	Check that sensor is plugged in and receiving power from the source
White	Solid	•	Operating Normally	No action needed
White	Flashing	• • •	Locate sensor function	Indicates which sensor you're interacting with when using "Locate" in the mobile app
Blue	Solid	•	Ready to be Provisioned	Typical state out of the box once sufficient power is provided.
Blue	Flashing	• • •	Connected to Bluetooth	No action needed FYI: LED blinks while the app is connected to the sensor
Orange	Solid	•	Factory OS	Contact support@density.io with serial numbers
Orange	Flashing	• • •	Low Power Mode	Confirm switch is PoE+ with at least 16W of power per port. Test ethernet cables.
Purple	Solid	•	Sensor cannot connect to the Density Server	Provision sensor via mobile app (mobile.density.io). If not resolved, run "Validate" in app and email results to support@density.io
Purple	Flashing	• • •	Server cannot connect to DNS	Verify DNS is available on VLAN. If no internal DNS server, review corporate firewalls to verify device can reach default DNS servers
Red	Solid	•	No Network Configuration	WiFi: Use the Spaces app to create a network template Ethernet: Verify DHCP server is available on VLAN
Red	Flashing	• • •	No Dongle Present or No ToF (reserved)	Occurs when device has not yet been provisioned and the Bluetooth Dongle is absent. Plug in Bluetooth Dongle to provision.

Unit Setup App

Used to configure units. iOS and Android application available - Go to mobile.density.io to download.

Option 1 – PoE switch

Connect one end of a Cat 5e or later ethernet cable to a 802.3af compliant network switch capable of providing 15.4W per port. Plug the other end of the ethernet cable into the Open Area sensor.

Density's Open Area device (model: OA1) requires PoE power to operate. You must use a PoE (802.3af) compatible switch or power injector that provides the specified 15.4W per port and be conscious not to exceed the switch load. For example, a 150W PoE switch can only host Open Area sensors assuming no other loads on that switch.

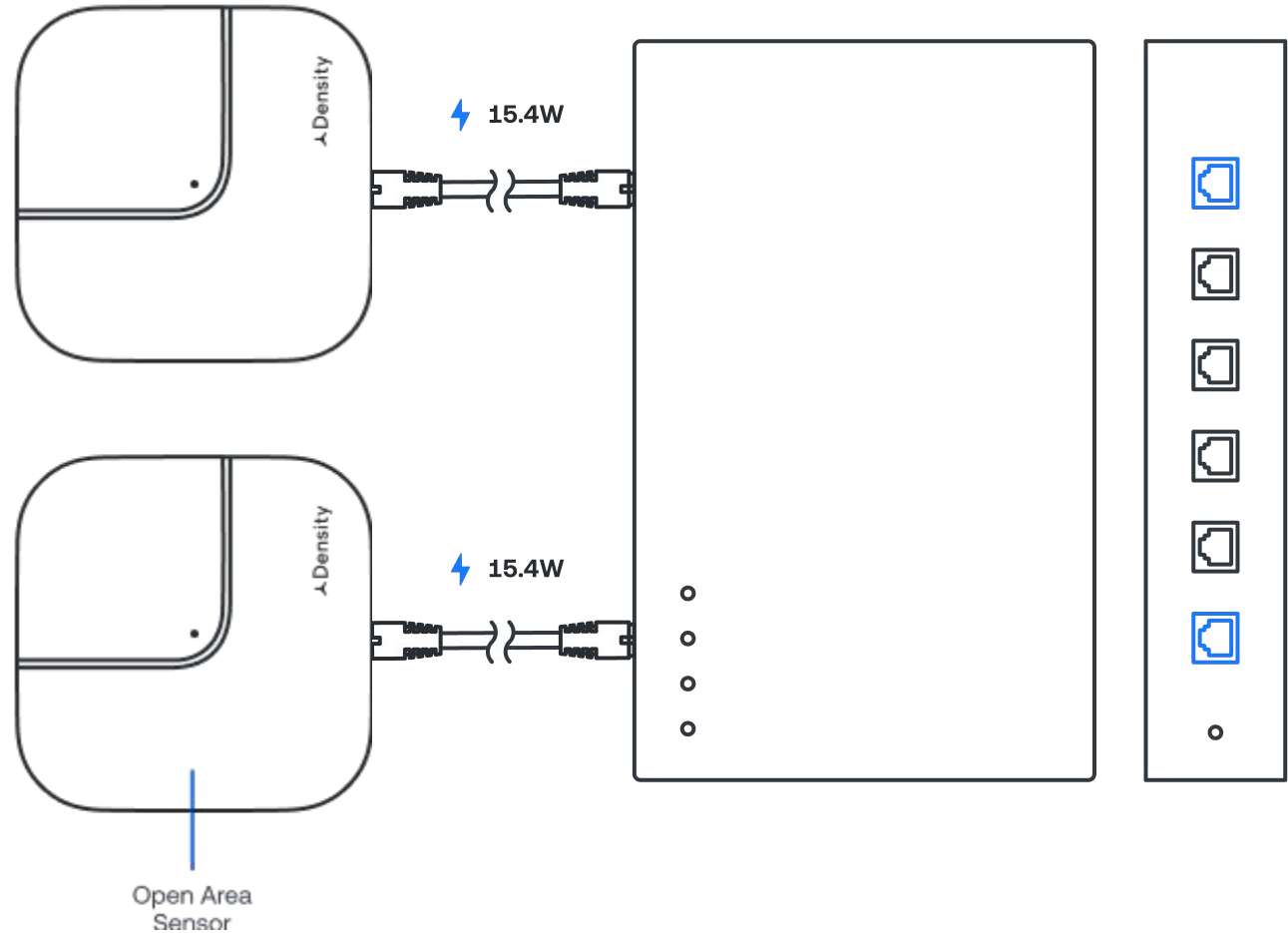

Option 2 – PoE injector using WiFi

Plug the PoE Injector into any standard 120v (US) wall outlet. Plug one end of a Cat 5e or later ethernet cable into the Data & Power Out port located on the bottom of the injector. Plug the other end of the ethernet cable into the sensor. Use the Unit Setup App to connect the sensor to a WiFi network.

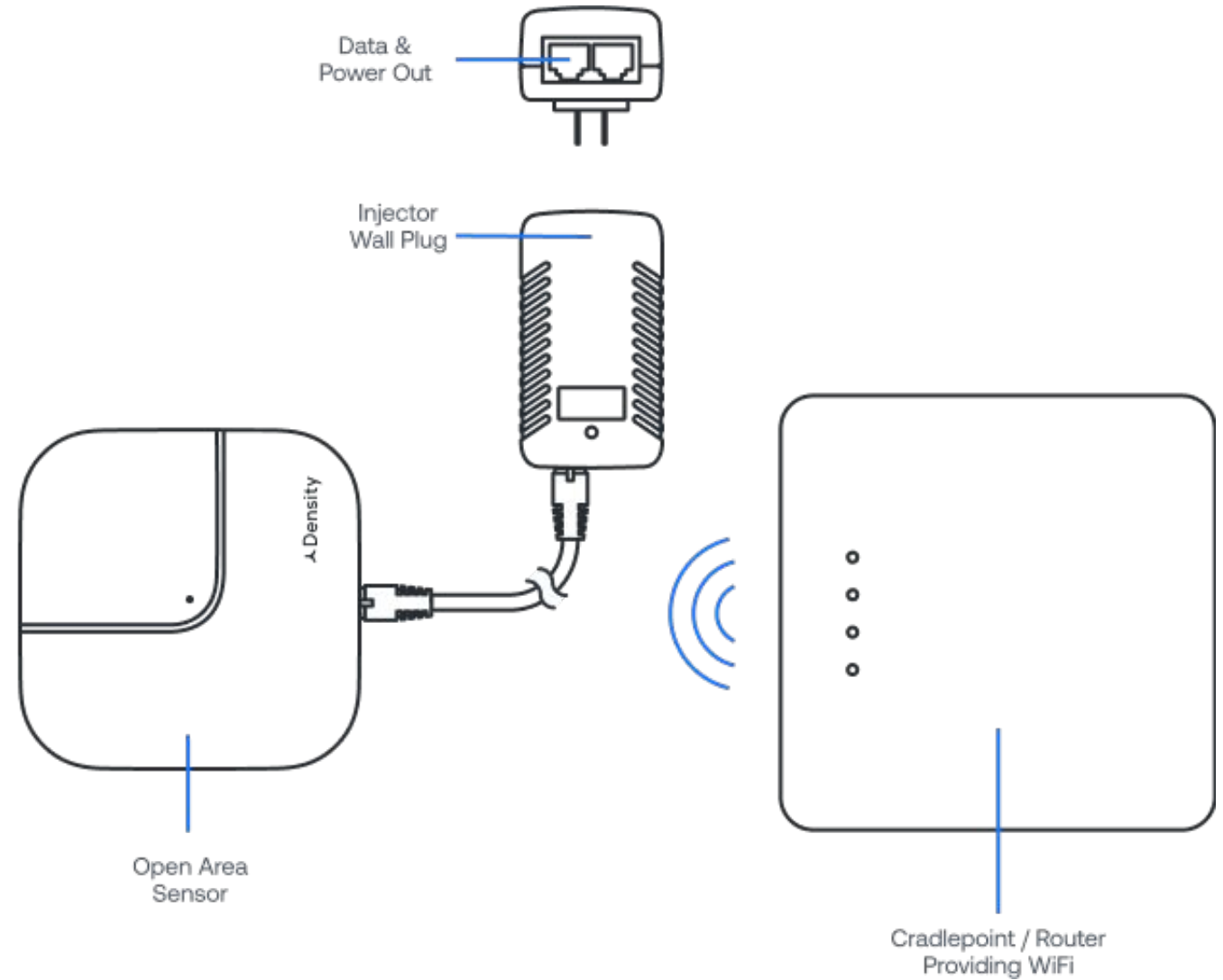

Option 3 – PoE injector using ethernet

Plug the PoE Injector into any standard 120v (US) wall outlet. Plug one end of a Cat 5e or later ethernet cable into a cradlepoint / router or non PoE switch. Plug the other end of the cable into the Data In port located on the bottom of the Injector. Plug an additional ethernet cable into the Data & Power Out port also located on the bottom of the injector. Plug the other end of the ethernet cable into the sensor.

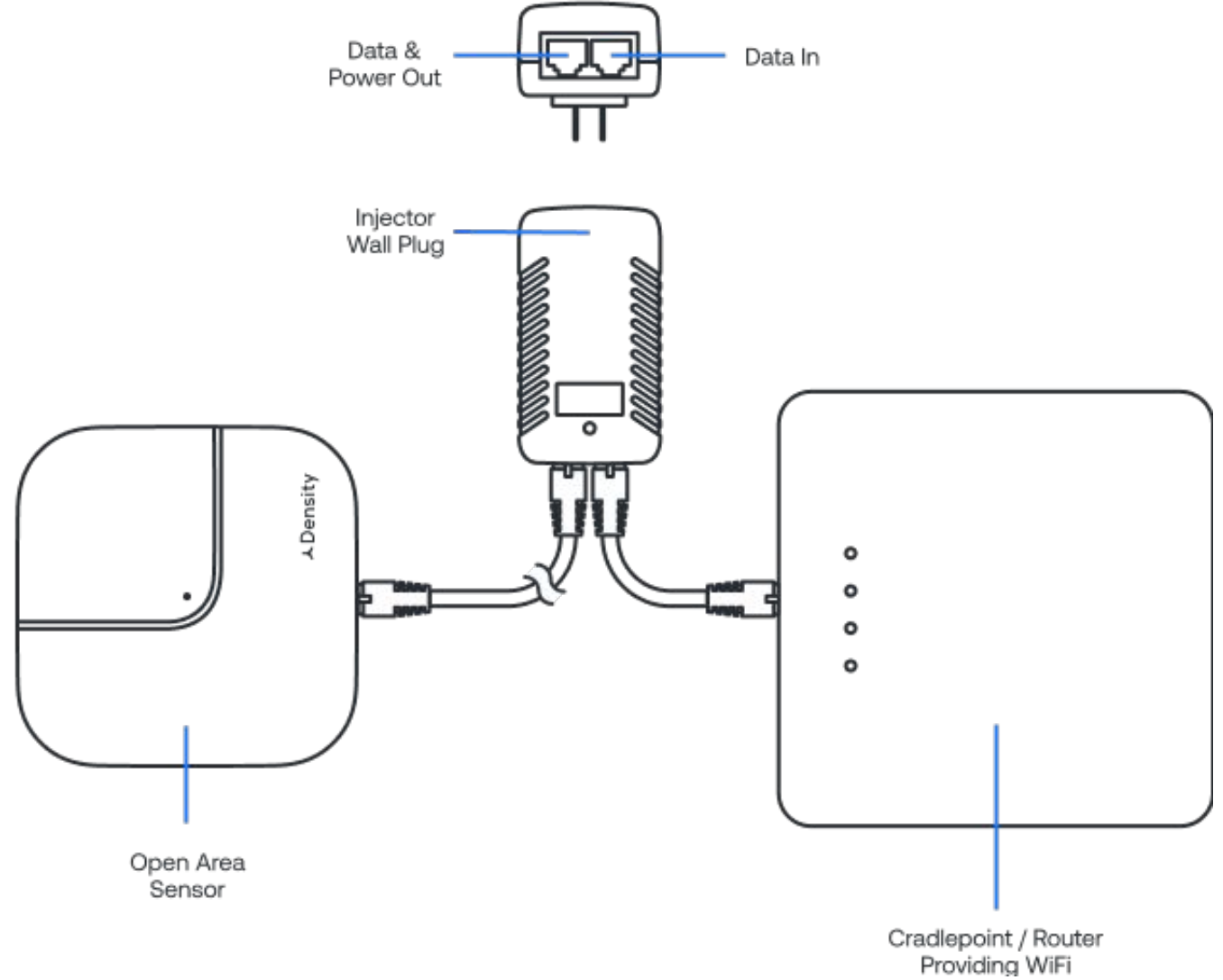

Power

Open Area sensors require standard power-over-ethernet PoE 802.3af, which can be supplied by an Ethernet switch or a PoE injector. The sensor can be connected via a wired network. For additional information, please see our [Open Area Power Requirements](#) and our [Network Requirements](#).

Device placement

The total detection area beneath an Open Area sensor is called the FOV (Field of View). The higher the sensor height, the greater the FOV coverage. To detect occupancy and people with Open Area, the sensor needs a clear line-of-sight to people passing through the area of interest. Any object obstructing the path between the sensor and a person passing through an area of interest will affect the sensor's ability to accurately detect the presence of that person. Please refer to the Install Height Chart on the following page to determine the minimum sensor height.

Sensor access and positioning

The rotation of the device during installation is important for sensor accuracy. The Ethernet and reset button are located on the back of the device. It is imperative to follow the orientation in the deployment plan.

Level mounting

In order to ensure sensor(s) are level to the floor it is imperative to check junction boxes and all parts provided by third party contractors are level and flush with hard ceiling or drop ceiling mounting surfaces. Look for crooked, loose, or sagging junction boxes.

Distance to wall

Open Area sensors may have data issues if installed too close to the wall. Ideally, Open Area sensors should be installed at least 30 inches from a wall or as far away from a wall as possible.

Device height

To determine the sensor height, measure the ceiling height in the desired install location. The maximum sensor height is 20ft (6.096 meters). The minimum sensor height is 7ft (2.1336 meters). Please refer to the table below for coverage characteristics based on sensor height.

Height (ft)	Major half (ft)	Minor half (ft)	Coverage (sq ft)
7	9.809	7.85249	242
8	11.5797	9.25479	337
9	12.9	10.3311	418
10	13.9217	11.1822	489
11	14.763	11.8897	551
12	15.5085	12.516	609
13	16.2092	13.1043	667
14	16.8825	13.6786	725
15	17.5122	14.2437	783
16	18.0485	14.7852	838
17	18.408	15.2695	883
18	18.4737	15.6438	907
19	18.4737	15.6438	907
20	18.4737	15.6438	907

Device interference

Items that are part of the underlying facility can interfere with sensor performance. Items that move slightly, rattle, or create any sort of static noise can create sensor issues. This section is particularly important because these items are difficult for the Deployment Planning team to see on deployment plans. Please look out for items such as:

- + Air vents
- + Air diffusers
- + Plants
- + Items “dangling” from the ceiling
(cords, cables, strings, etc.)
- + Blind handles
- + Ice machines
- + Fans
- + Anything with a motor
- + Elevators

Mount Plate Installation

06

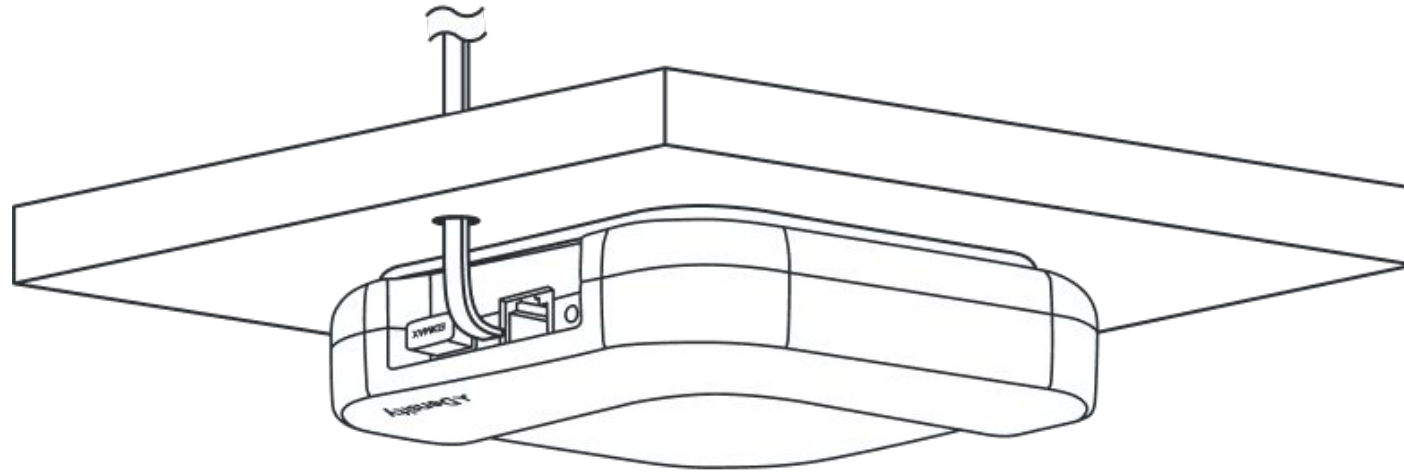

Materials NOT included

- + 4pcs #8 x 1.25in flat head screws
- + 4pcs multi-surface anchors
- + Mallet
- + Drill
- + 3/4in drill bit
- + 3/16in drill bit
- + 1/8in drill bit
- + Ethernet cable (Cat 5e or later)
- + Level

Power & connectivity

All sensors require power over ethernet and internet connectivity.

Ceiling mount plate assembly

The ceiling mount plate can be mounted to solid or hollow ceiling surfaces.

Position mount bracket on the ceiling in the prescribed location, with one of the square slots pointing in the direction the ethernet jack needs to point.

Note: OALR does not come with any screws or anchors. Please utilize appropriate screws and anchors for the given surface type.

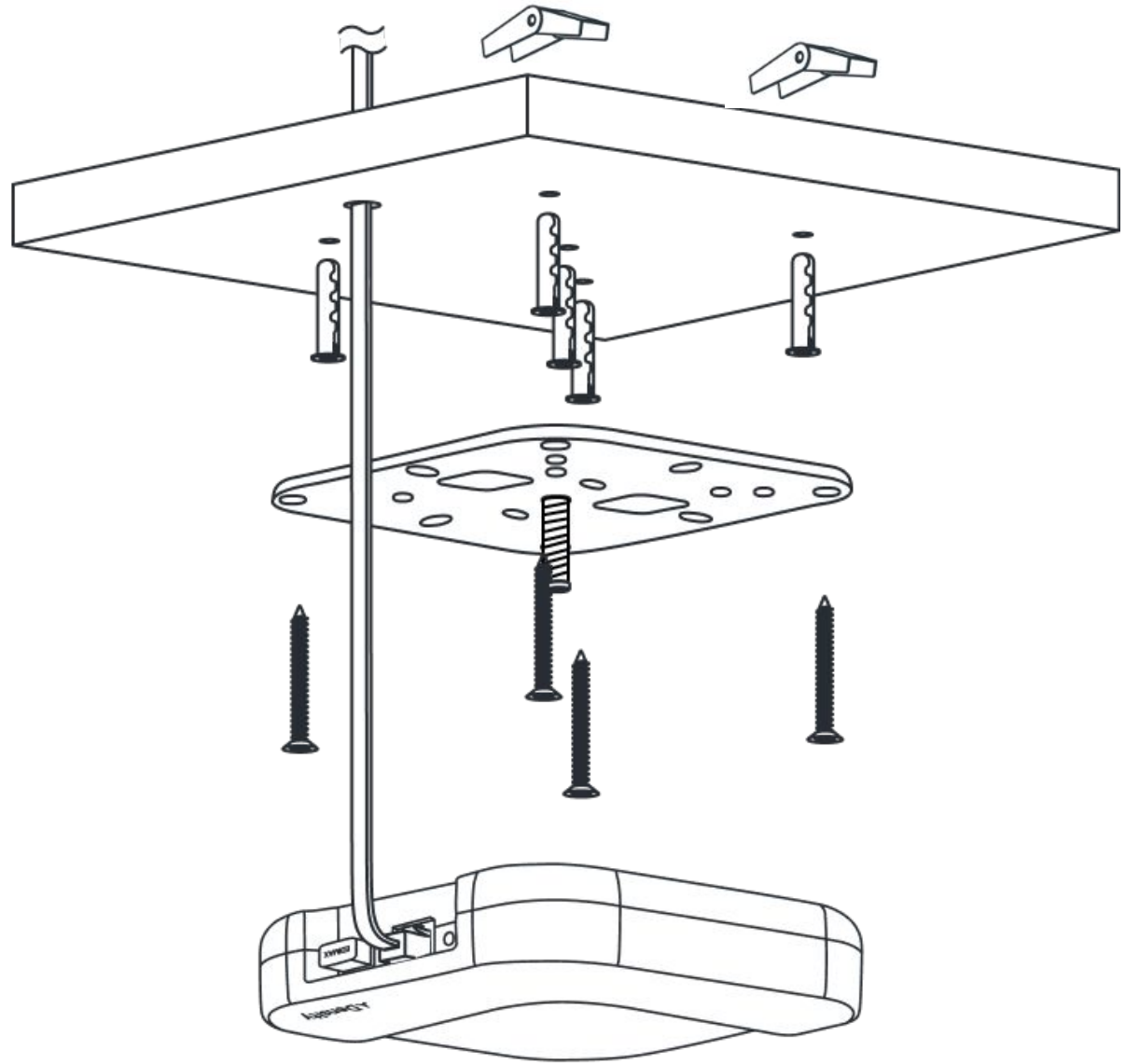

Step 1: Mark placement

Using a pencil or pen, mark the location on the ceiling for anchor screws. We recommend fastening the mount plate with at least two screws. If you will be using the optional cable pass through openings, outline the opening location also.

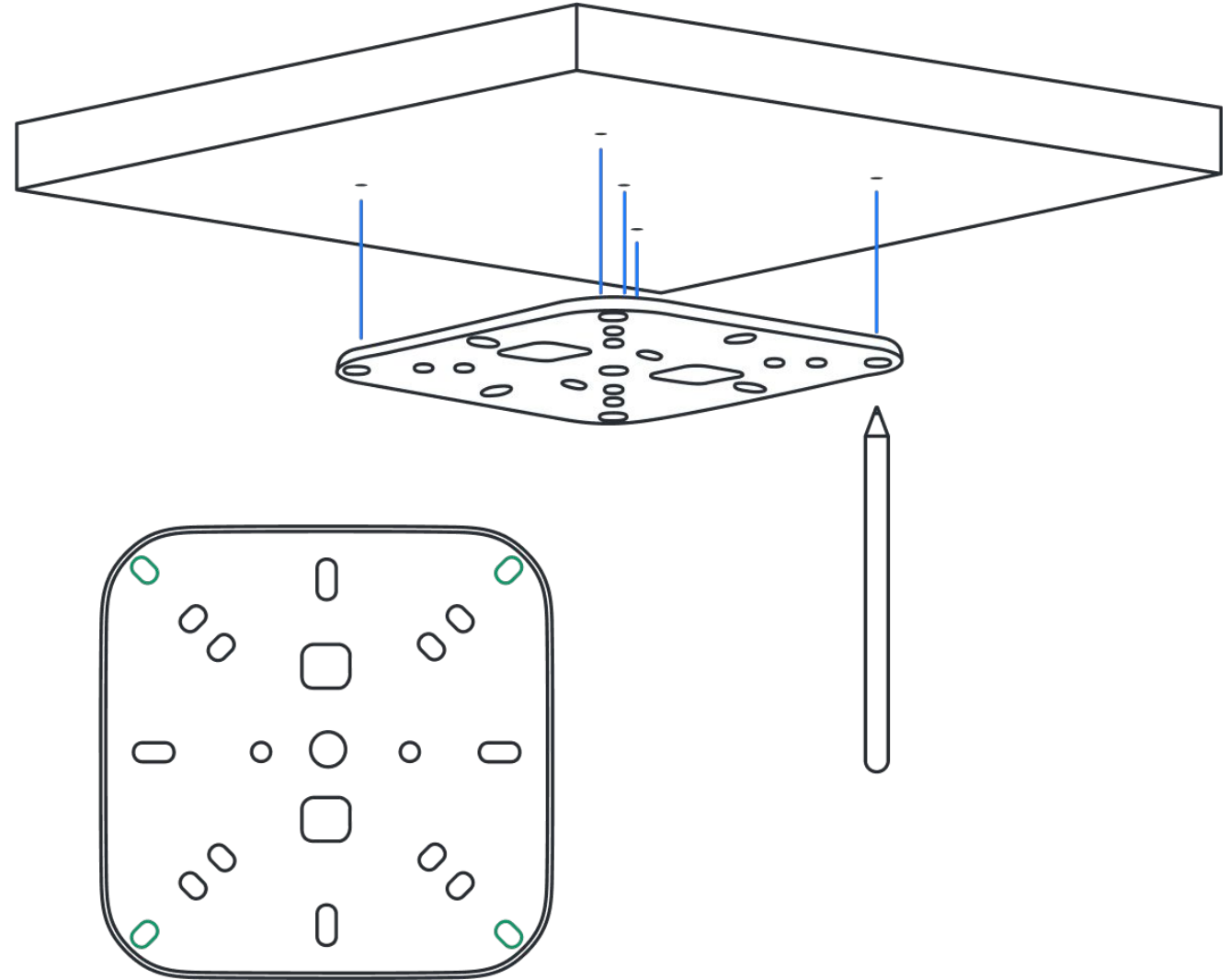

Step 2: Drill holes

Drill a hole through each pencil mark using the recommended sizing for the mounting hardware and anchors.

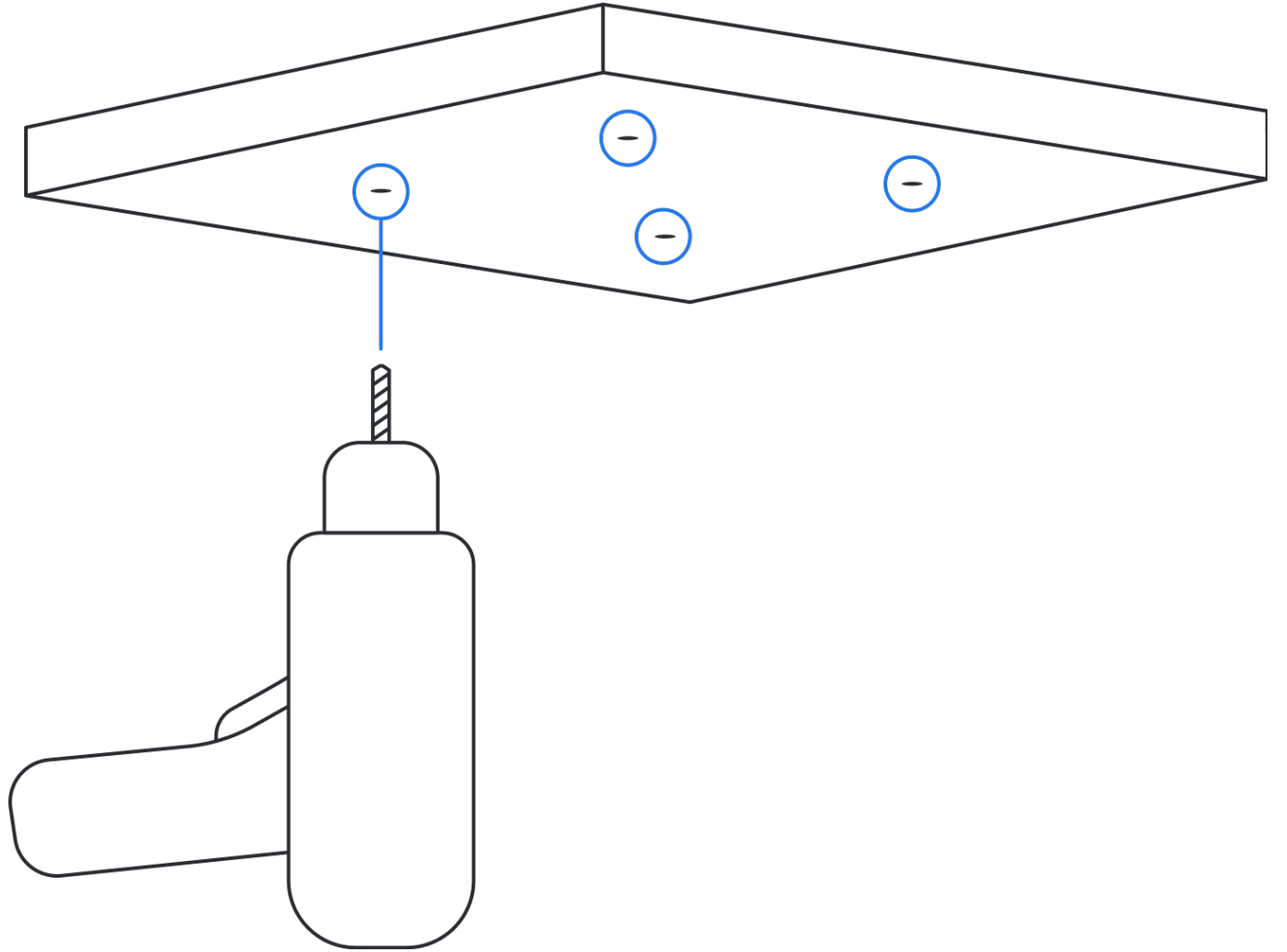

Step 3: Insert anchors

For hollow surfaces only, use a mallet to tap the anchors into each hole. Anchors should be flush with the surface.

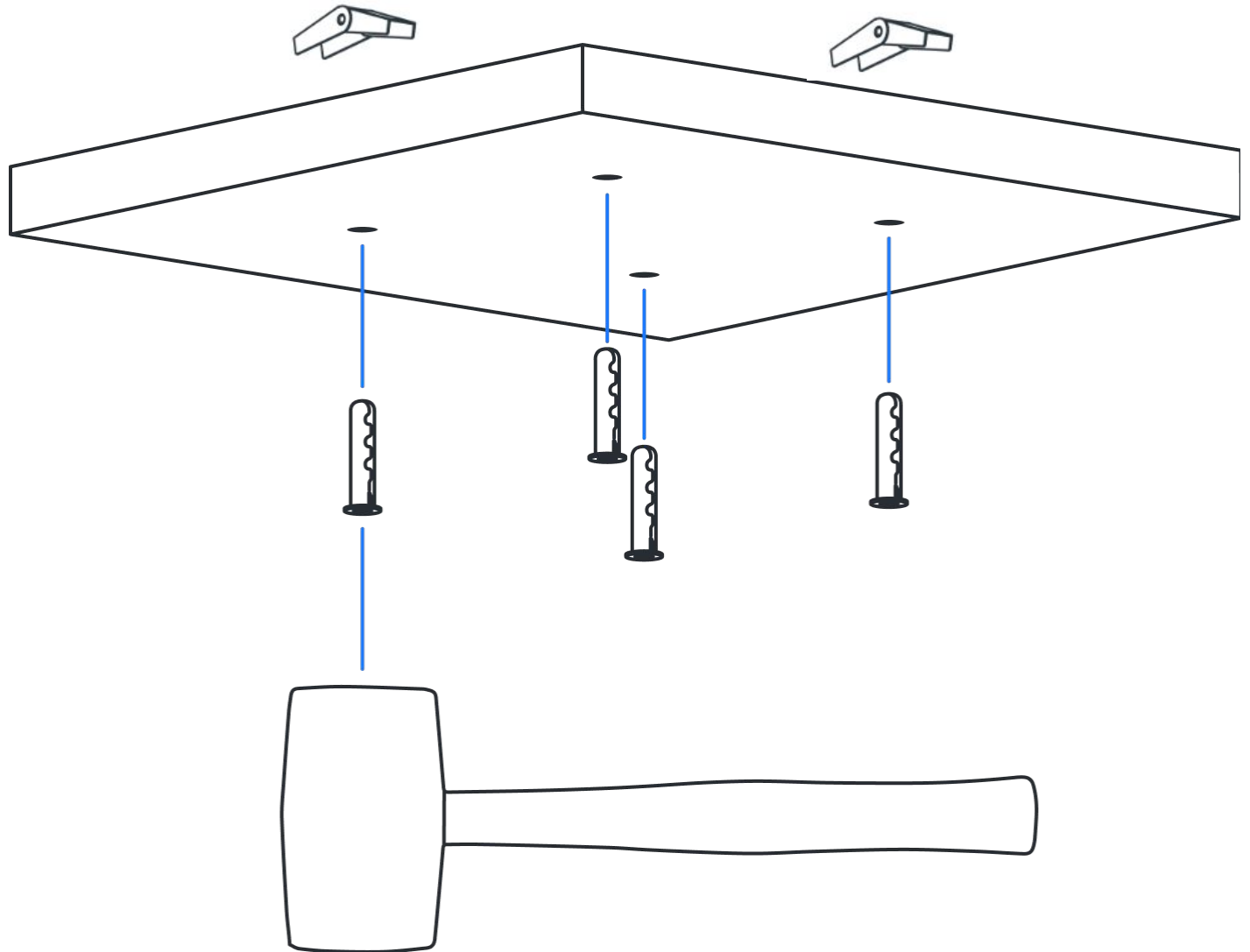

Step 4: Install mount plate

Align the holes in the mount plate with the installed anchors. Use a drill with #2 Phillips Screwdriver bit to drive each screw into the drywall anchors. Screws can also be driven in manually with a standard Phillips head screwdriver.

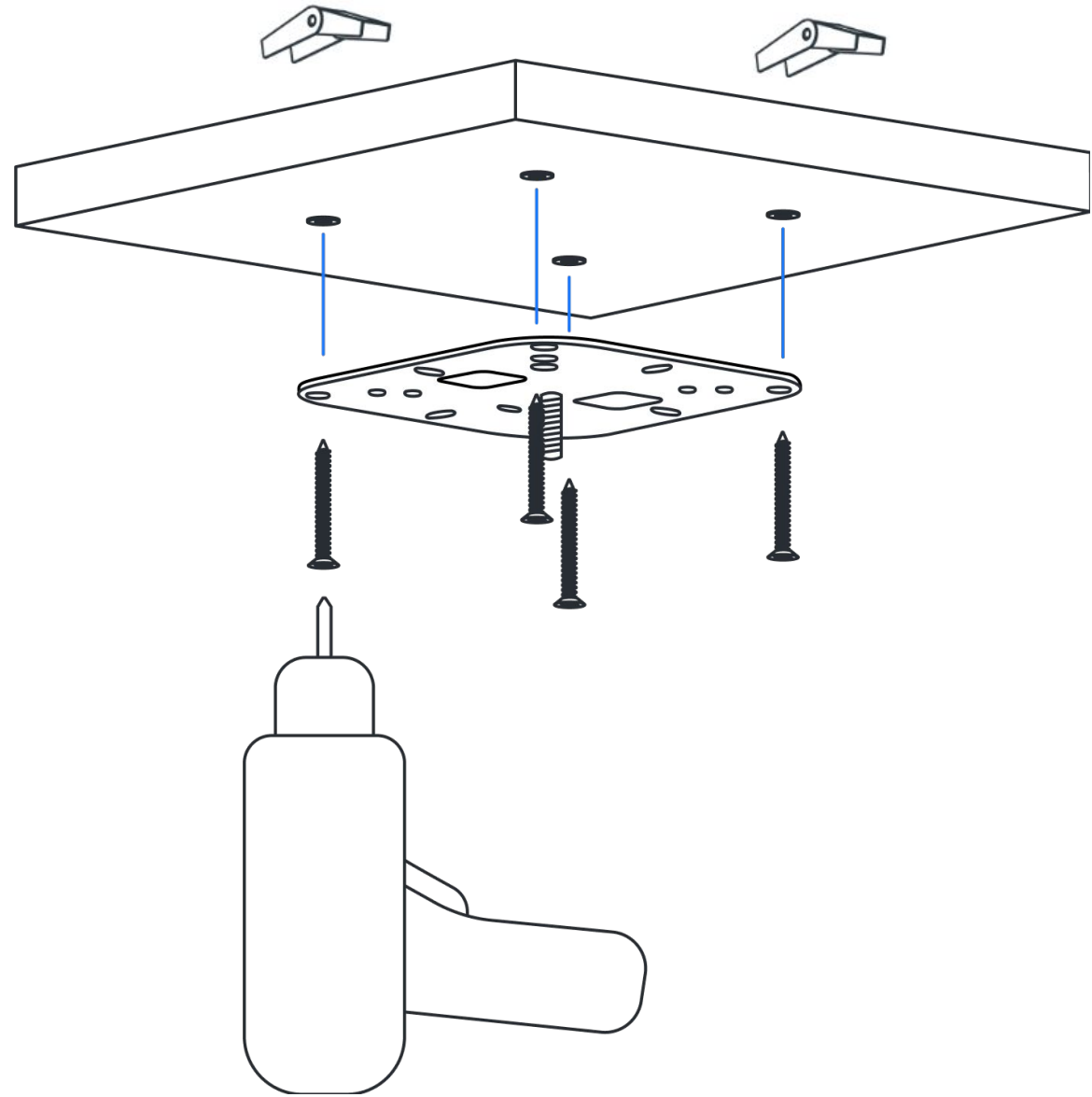

Step 5: Drill cabling hole

If you are not using the optional cable pass through hole, drill a hole using a 3/4in (16mm) drill bit to route the cable through.

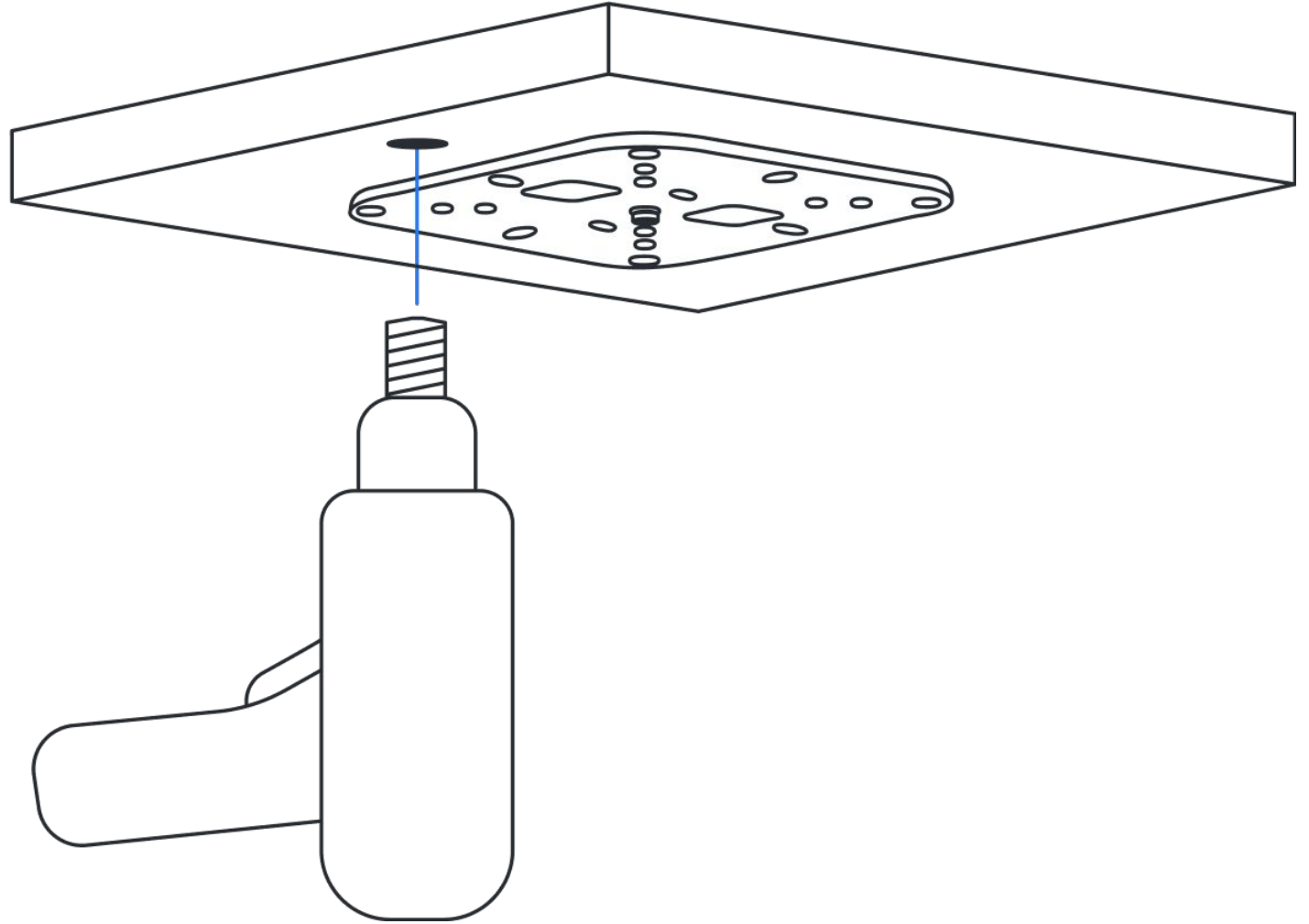

Step 6: Route cable

Route the ethernet cable through the drilled hole. Make sure the cable passes through opening in mount plate if you're using the Cable Pass Through.

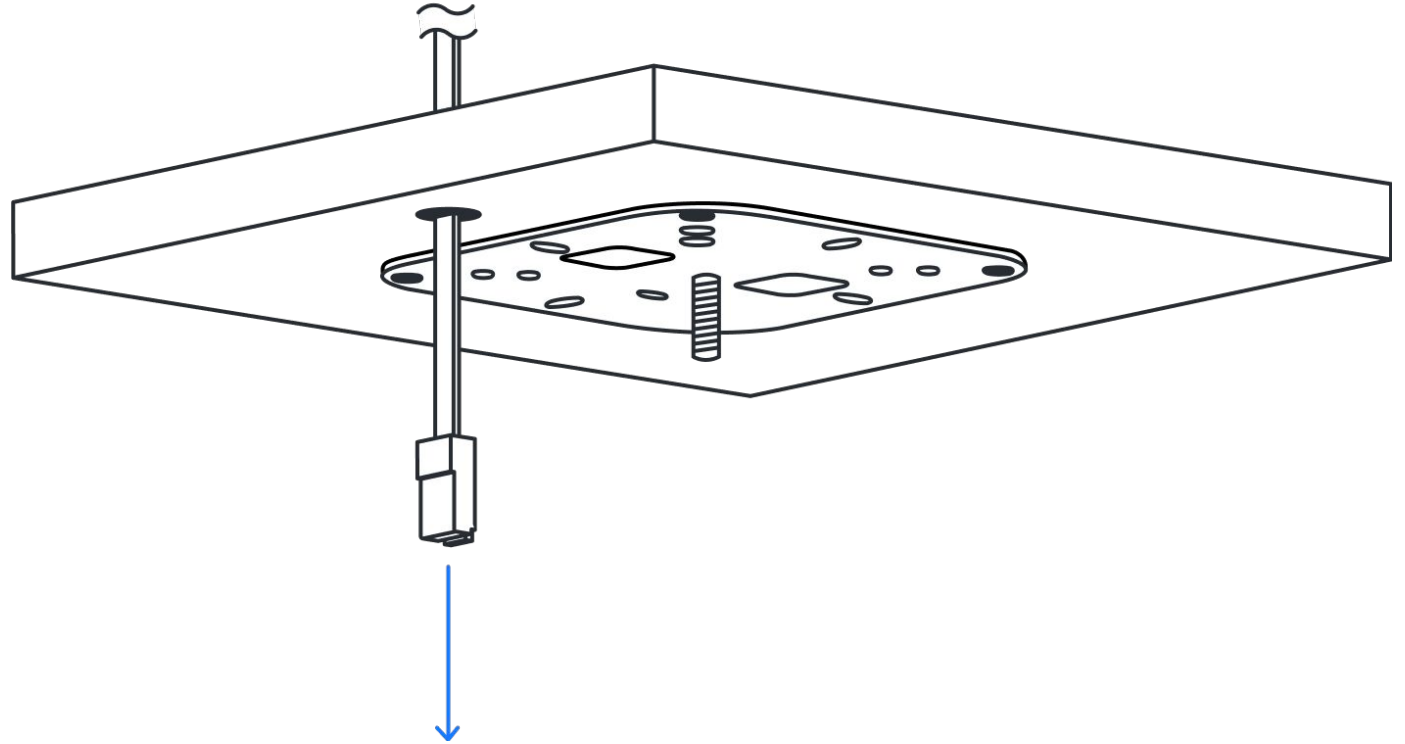

Step 7: Attach Open Area sensor

Attach the Open Area unit by threading onto the bracket. Pull the ethernet cable through approximately 6 inches out from the opening in the ceiling.

Screw the unit on all the way until it stops, then back it off to the prescribed location using the ethernet jack as the location guide.

Warning! Do not over-tighten as this can damage the unit.

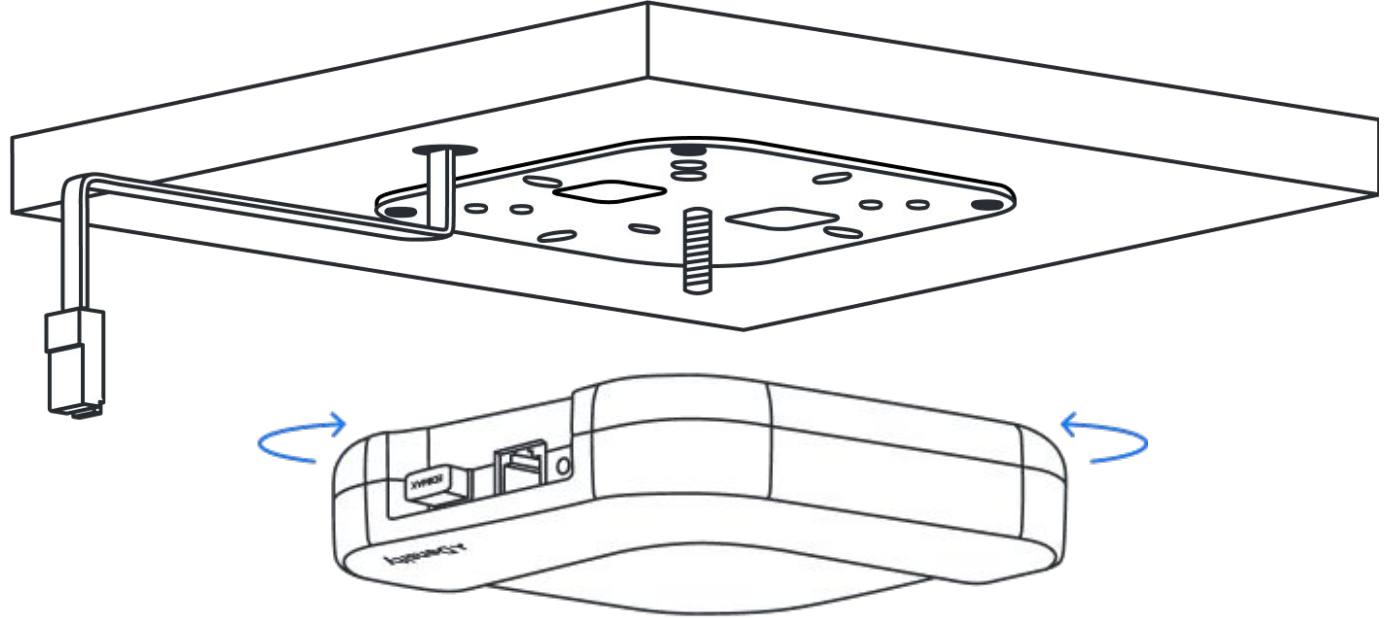
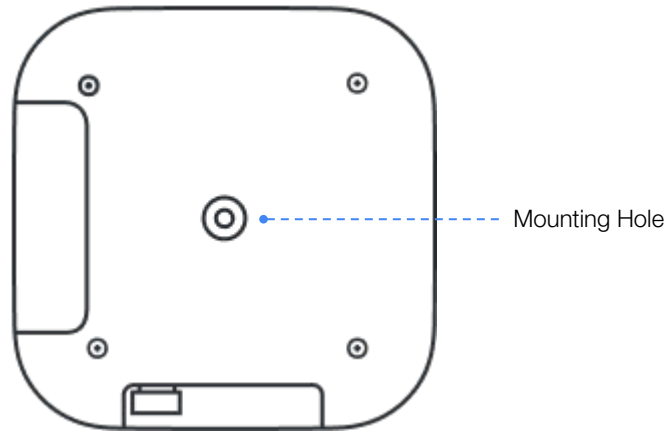

Step 8: Plug in cable

Plug the ethernet cable into the Open Area sensor.

Ensure the Open Area unit is level and parallel to the floor.

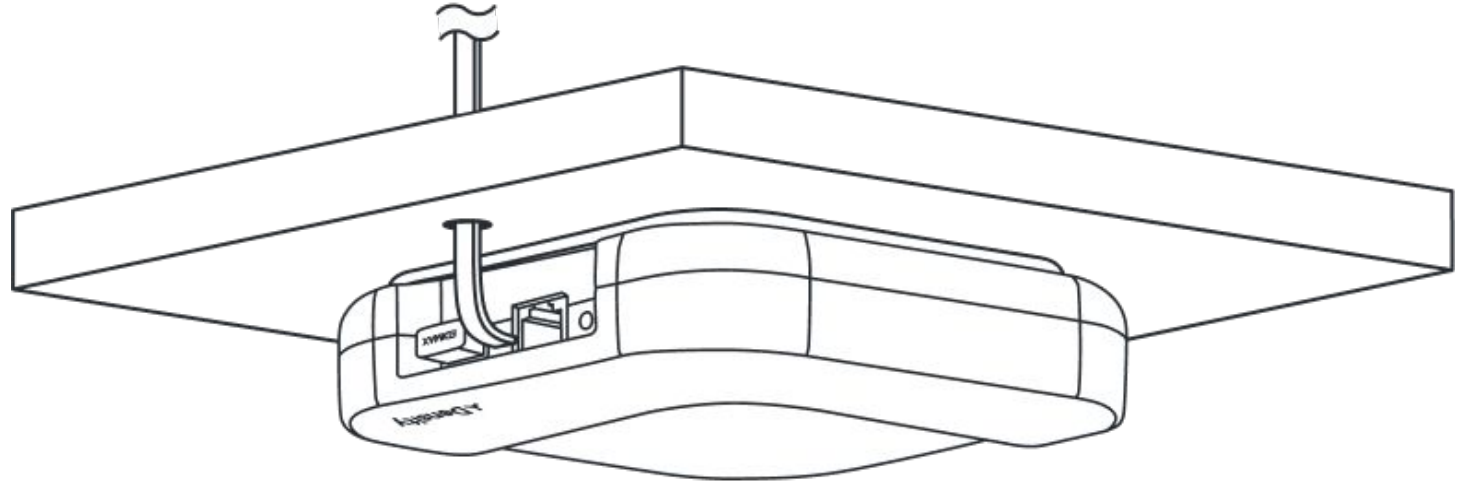

Alternate Mounting Options

Note: Please contact your Density Project Manager or support@density.io to order mounting kits for these mounting options

07

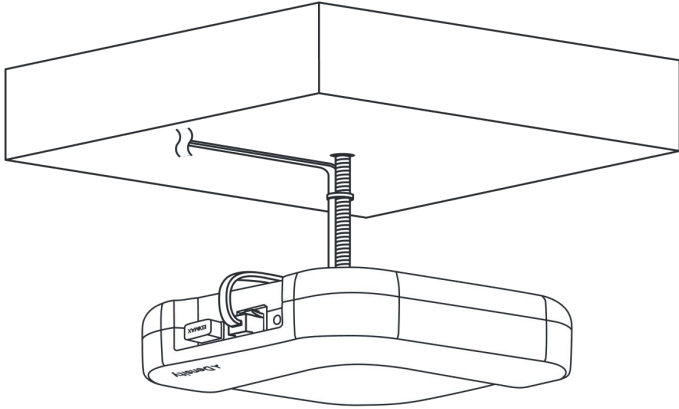

Suspended Ceiling Mounting (Available to Order)

The Threaded Rod Mount is used for mounting the sensor to solid ceiling types (wood, concrete, steel and hollow).

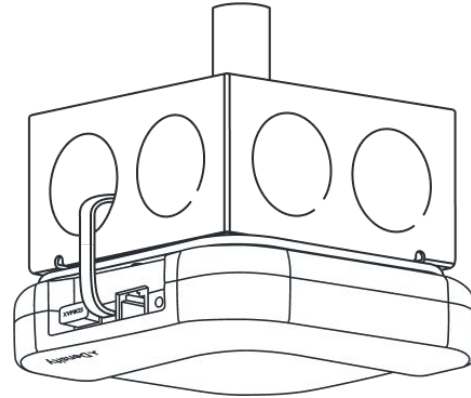

Junction Box Mounting

The Junction Box Mounting is used for mounting the sensor to square, round, or octagonal junction boxes.

Suspended Ceiling Mounting

For solid ceiling types
(wood, concrete, steel, and hollow)

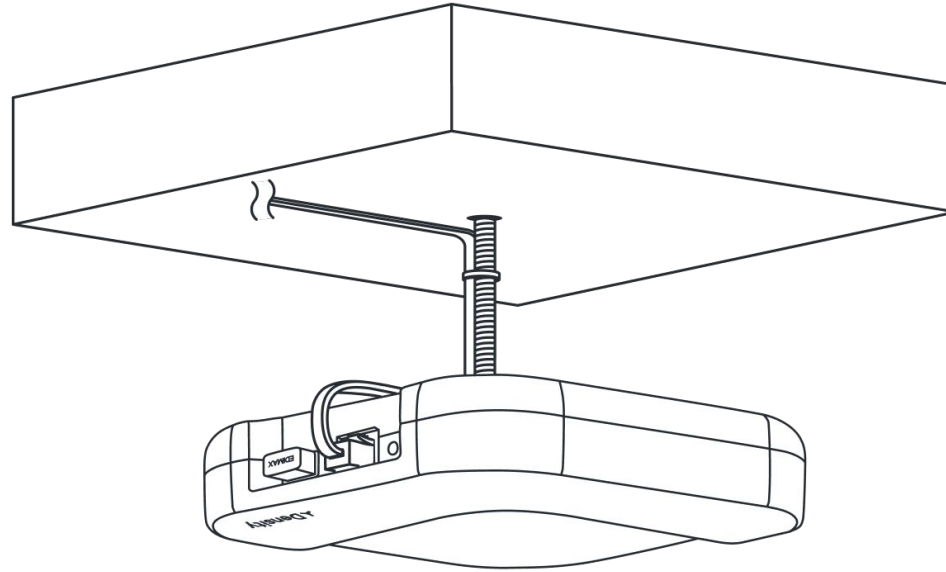

Suspended Ceiling mount (available for order)

- + Hex Key
- + Threaded Rod Anchor - Wood
- + Threaded Rod Anchor - Steel
- + Expansions Anchor - Concrete
- + Installation Tool - Concrete
- + 1/4in-20 Toggle Anchor - Hollow
- + Steel Washer
- + Hex Nut

Materials NOT included

- + Drill
- + Hammer
- + 5/8in Drill Bit
- + 5/8in drive socket (wood only)
- + 1/2in drive socket (steel only)
- + ANSI 3/8in masonry bit (concrete only)
- + 1/4in-20 threaded rod
- + Cable management clips
- + PVC pipe (optional for cable management)
- + Ethernet cable (Cat 5e or later)

Power & connectivity

All sensors require power over ethernet and internet connectivity.

Threaded rod anchor assembly

The Entry LR Sensor can be suspended from a 1/4in 20 threaded rod and mounted to solid wood, concrete or steel ceiling types using the threaded rod anchors (not included).

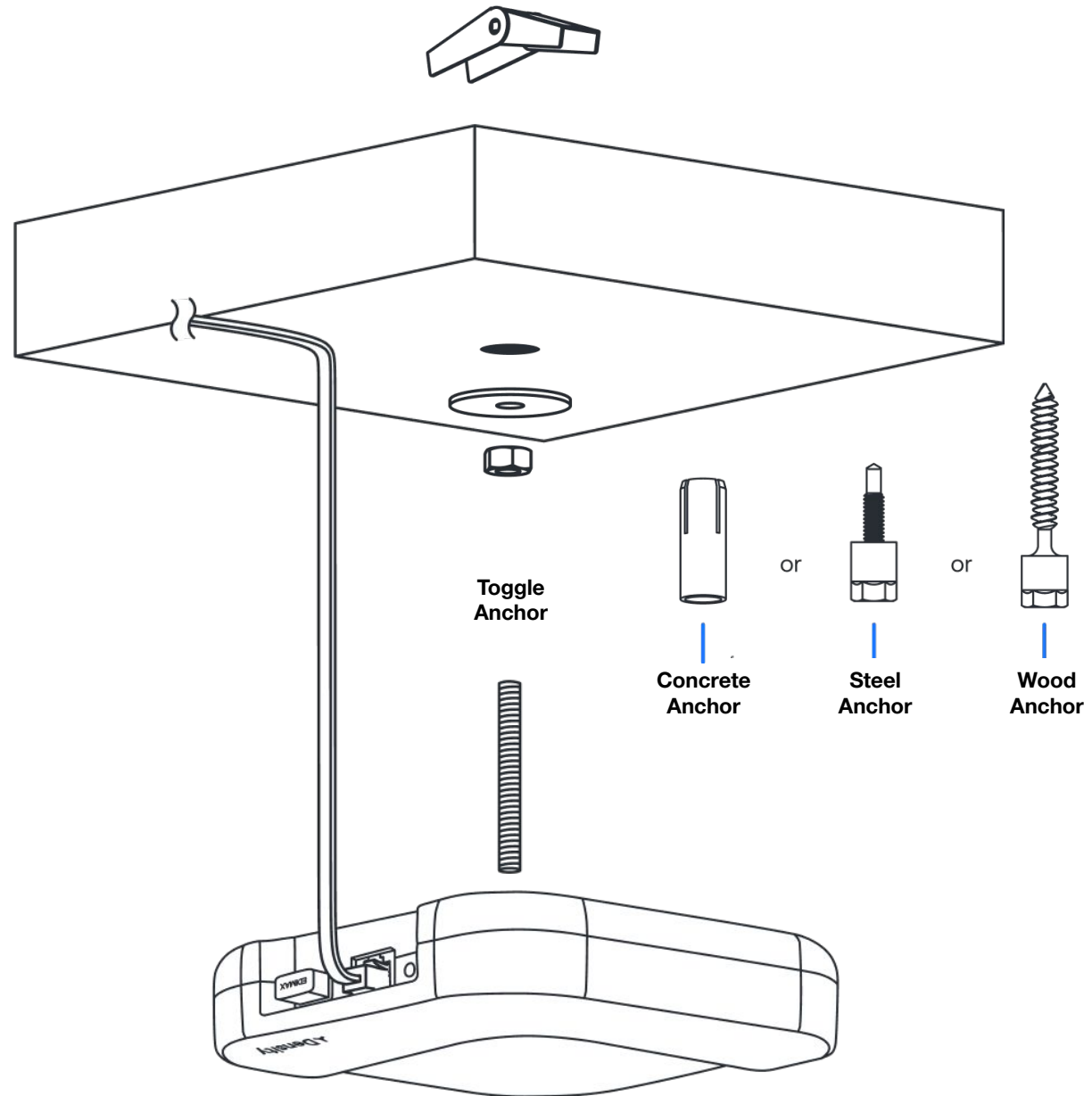

Suspended Ceiling anchors

Install directly into a mounting surface to suspend a threaded rod. Three different mounting anchors are specifically designed for wood, steel, and concrete surfaces. The wood and steel anchors require a drill along with the appropriate sized drive socket (not included) for installation. The concrete anchor requires a hole drilled by an ANSI 3/8in masonry bit, as well as a hammer (not included) and an installation tool (not included).

Wood Anchor

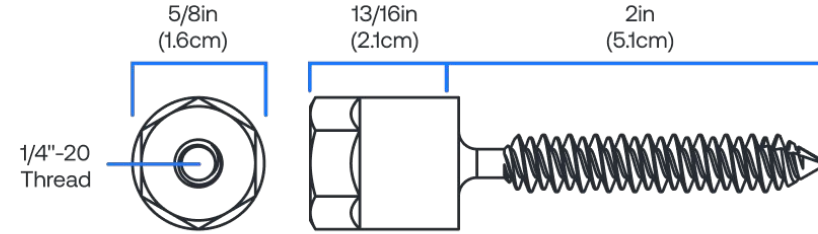

Steel Anchor

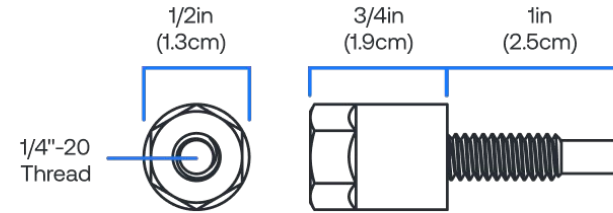

Concrete Anchor

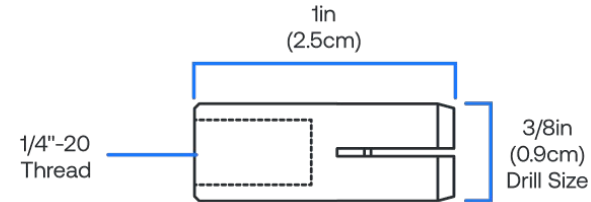

Toggle Anchor

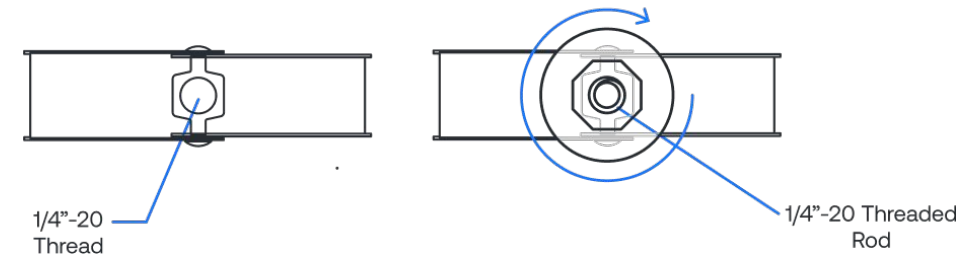

Step 1: Install threaded rod anchor

Wood and Steel installation:

Use a drill and a drive socket (5/8in for wood, 1/2in for steel) to drive the anchor into the ceiling until the bottom side of the anchor head is flush with the ceiling.

Concrete installation:

Anchors for concrete require a hole drilled by an ANSI 3/8in masonry drill bit. To install, place the anchor into the drilled hole, insert the required installation tool into the anchor, and drive with a hammer until the thicker portion of the tool makes contact with the anchor. When installed, anchors sit flush with the surface.

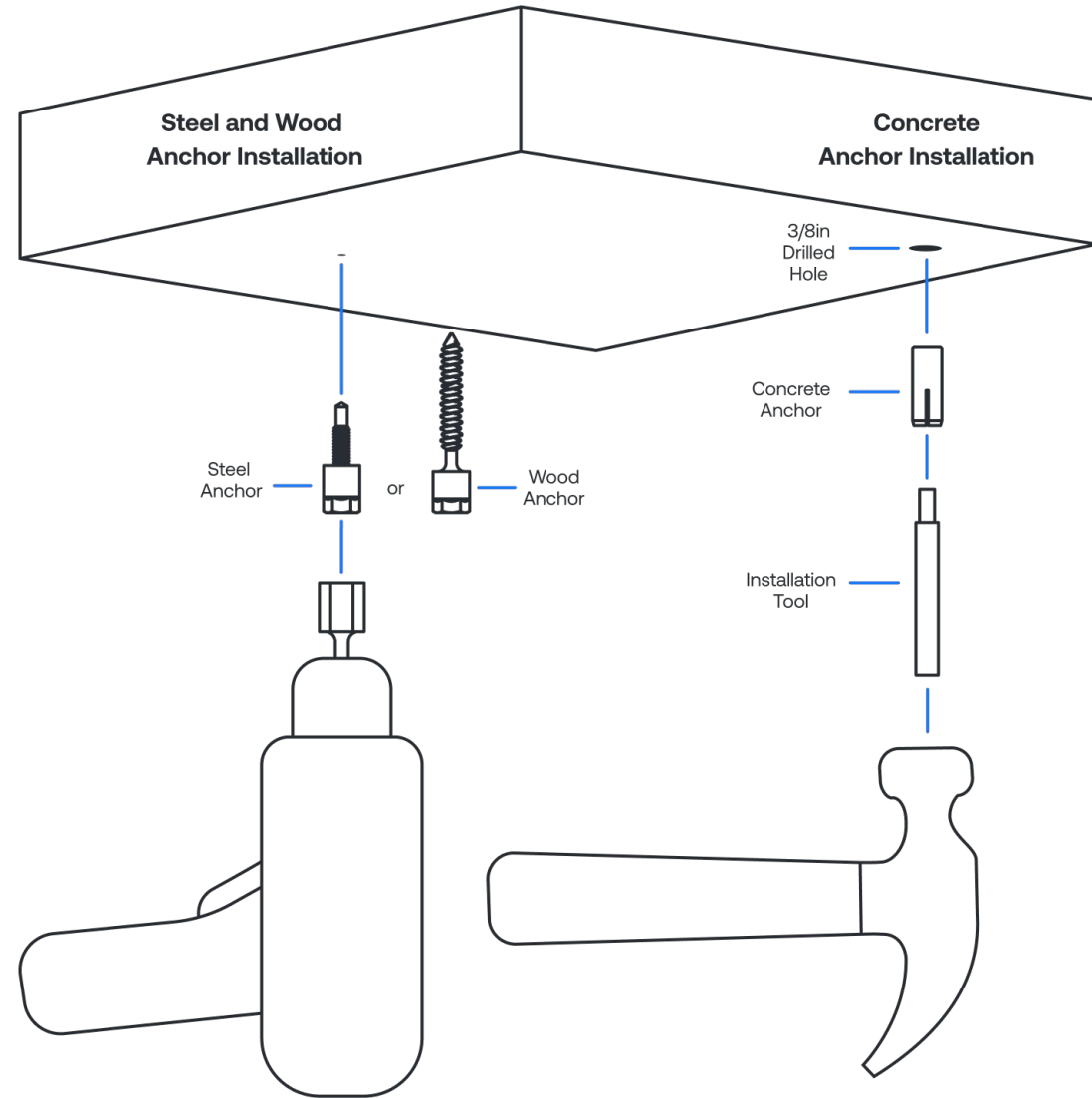
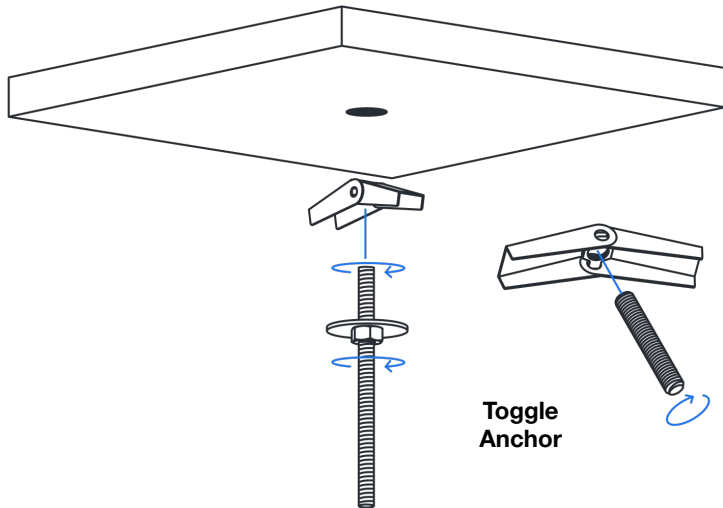

Step 2: Attach Entry LR Sensor

Attach the Entry LR Sensor to the threaded rod by inserting the threaded rod into the 1/4in-20 threads on the back of the Open Area sensor and twisting the sensor onto the rod until tight.

Screw the unit on all the way until it stops, then back it off to the prescribed location using the ethernet jack as the location guide.

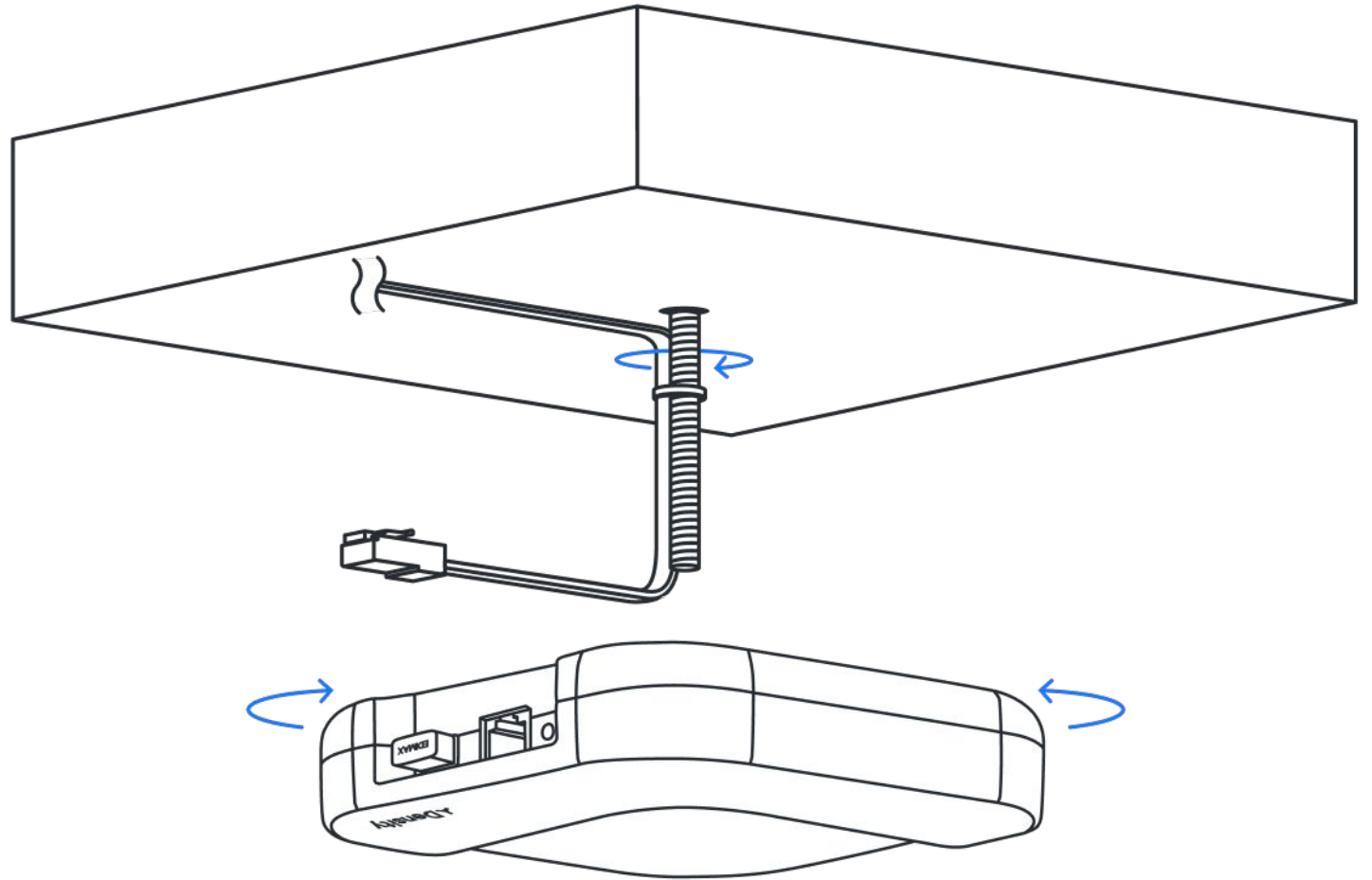
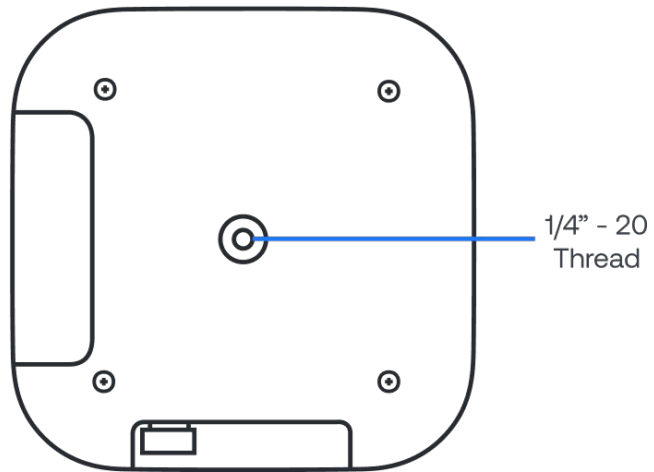

Step 3: Plug in cable

Plug the ethernet cable into the Entry LR Sensor.
Ensure the Open Area unit is level and parallel to
the floor.

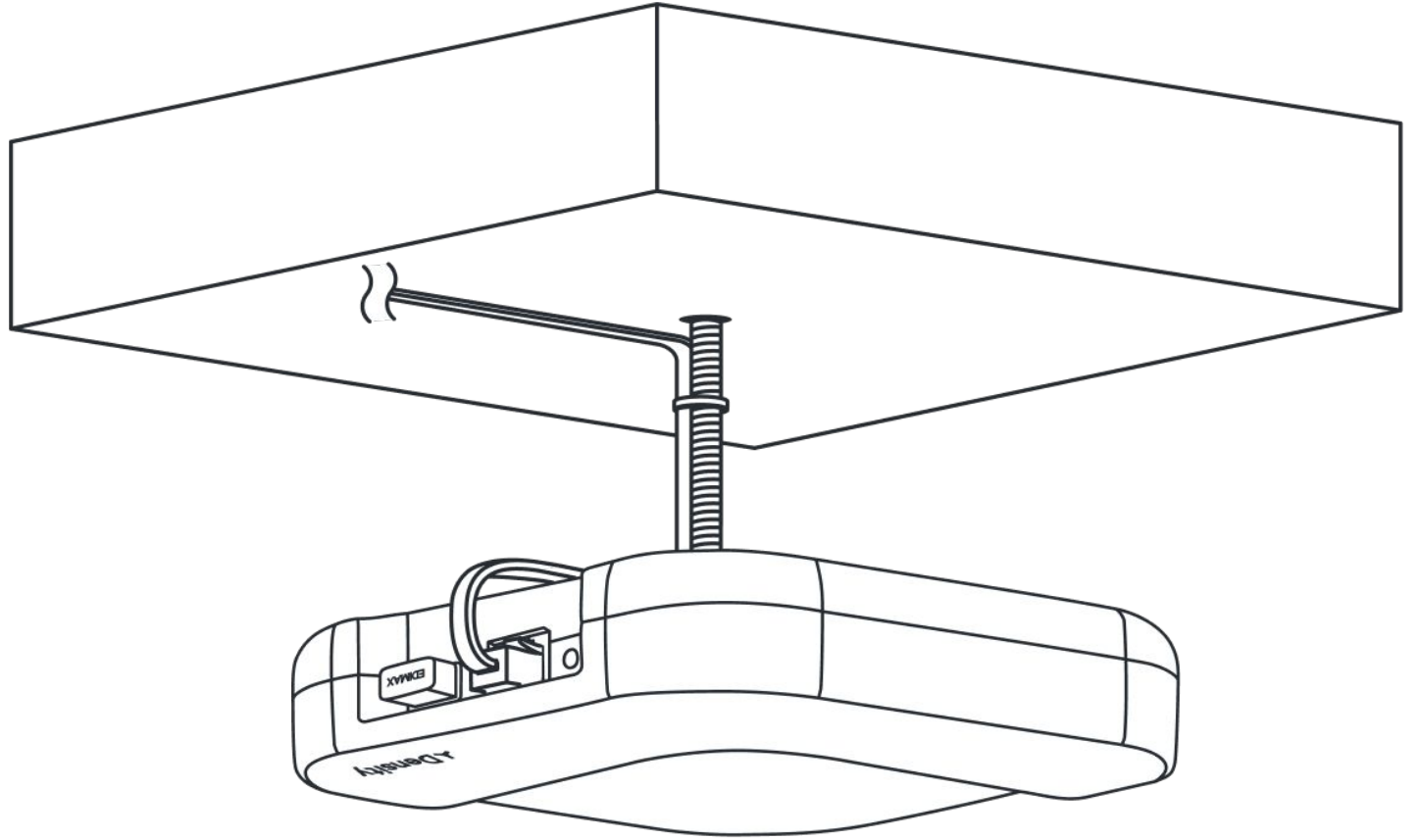

Step 4 (optional): Cable management

A 1/2in PVC pipe can be used to run the cable and rod through. Before assembly, cut the PVC pipe to the proper length and drill or cut a notch or hole at the top of the pipe to allow for cable relief. For optimal cable aesthetics, we recommend using a flat white Cat 5e or greater ethernet cable as shown. Make sure to use a pipe size with a minimum inner diameter of 0.62in (1.6cm). The cable can be attached to the ceiling using a variety of screw or nail in cable management clips.

Be sure to follow recommended minimum bend radius guidelines for any type of cable used.

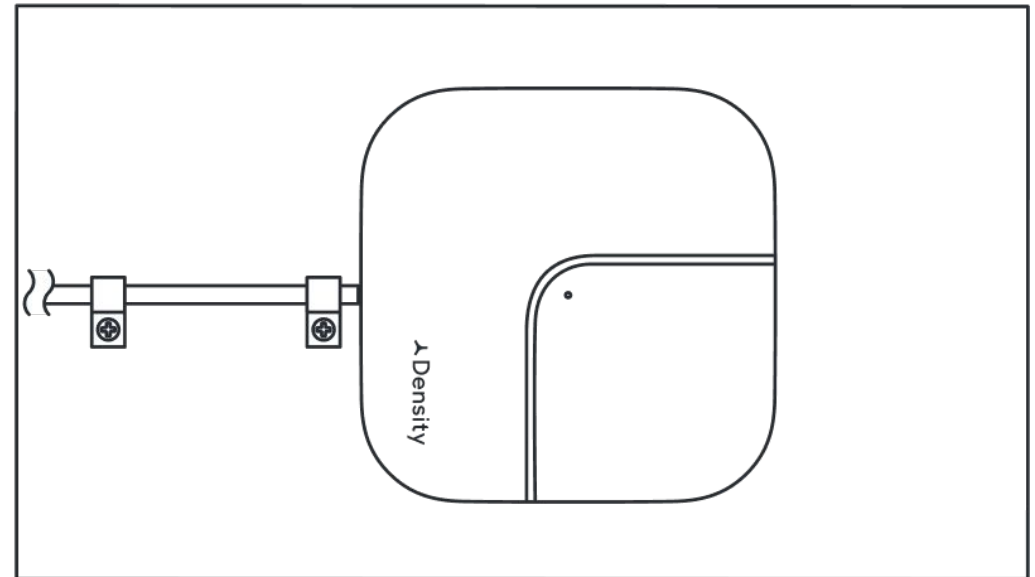
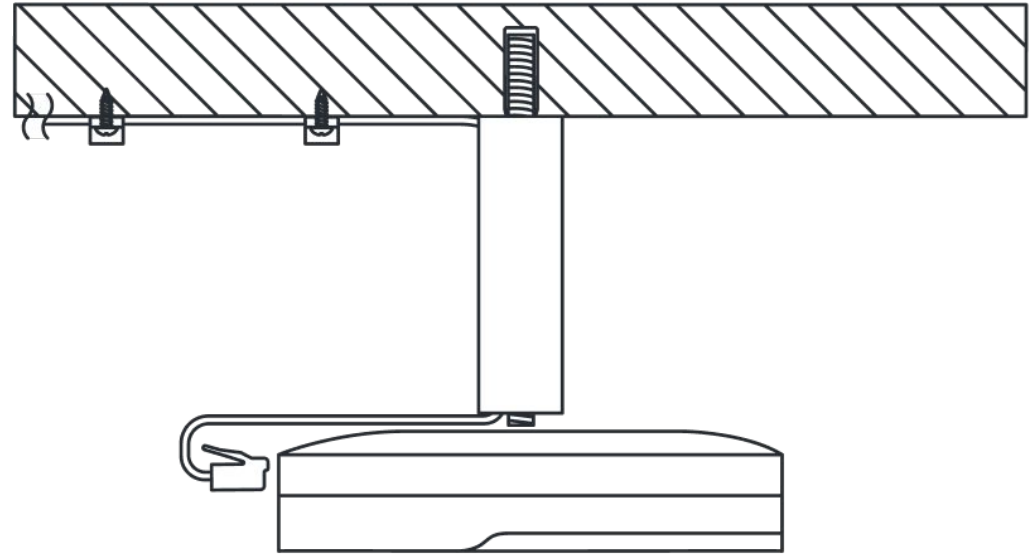
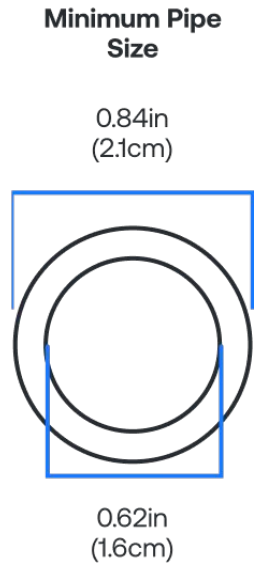

Installation complete

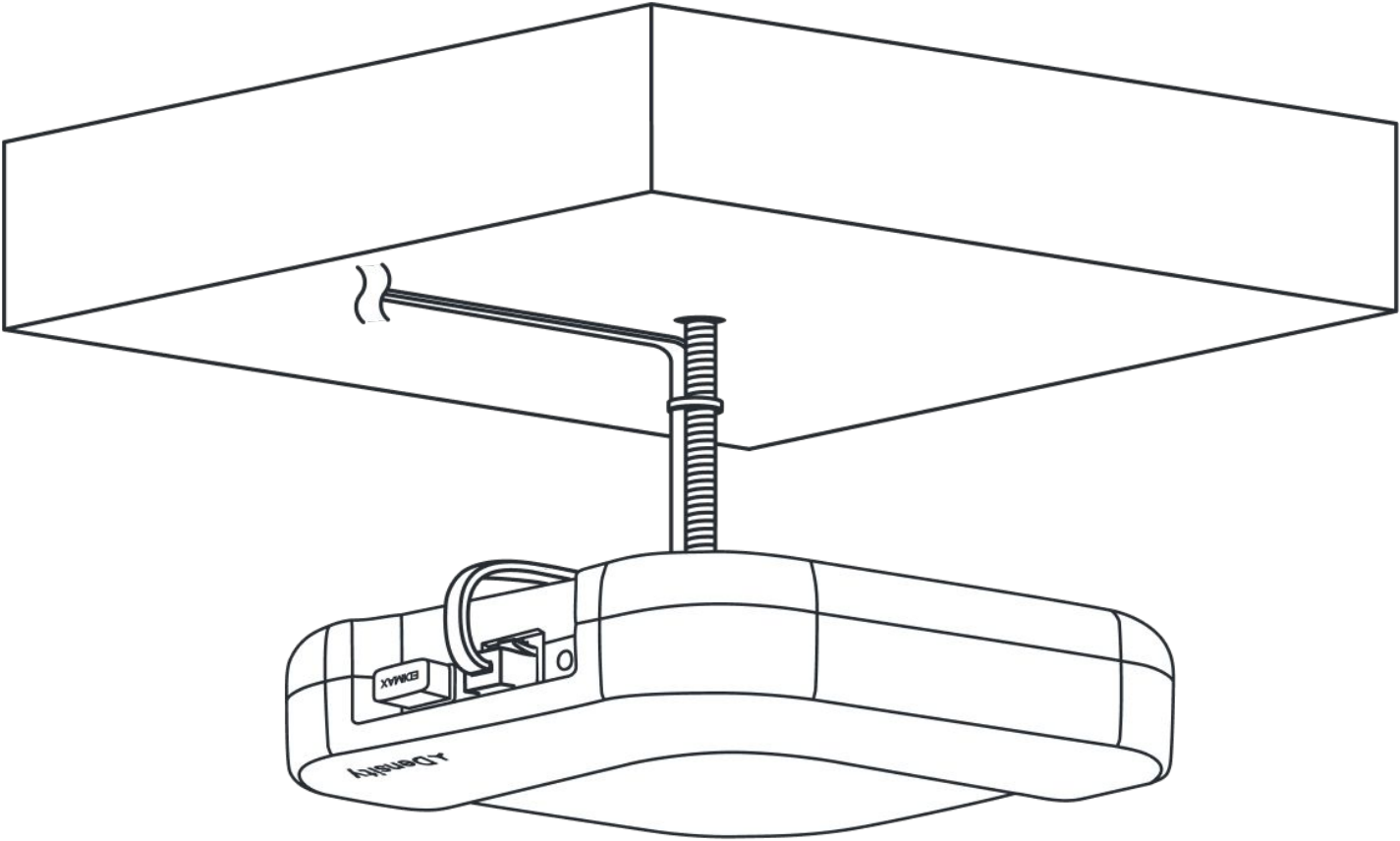

Junction Box Mounting

For mounting to square, round, or octagonal junction boxes

Please ensure that the junction box is not sagging, loose, or crooked.

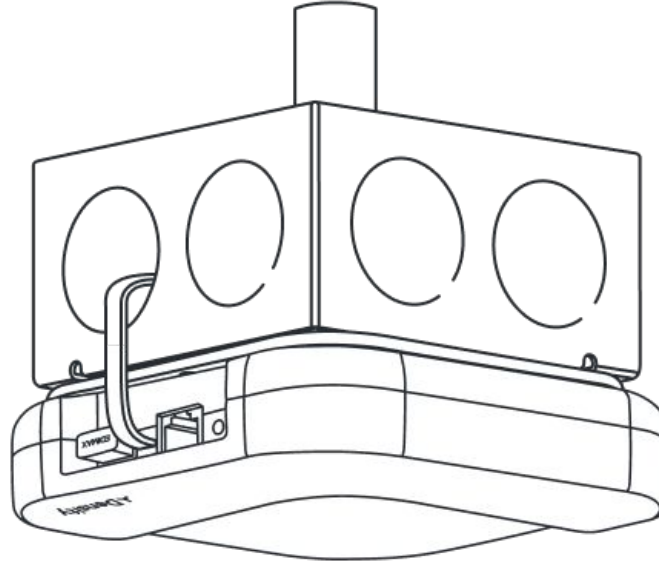

Junction box mounting

- + Mount plate

Materials NOT included

- + Drill or screwdriver
- + Junction box
- + Ethernet cable (Cat 5e or later)
- + Screws

Power & connectivity

All sensors require power over ethernet and internet connectivity.

Junction box mounting

With the junction box hung and positioned, affix the mount plate to the junction box using the appropriate hole pattern and screws.

Mounting Plate

- A. Ceiling or Drop Ceiling Tile
- B. 4" Square Junction Box (US)
- C. 4" Round Junction Box (US)
- D. 3.5" Round Junction Box (US)
- E. Single-Gang Outlet Box (US)
- F. Pass Through
- G. Auxiliary Hole
- H. 1/4"-20 Threaded Stud

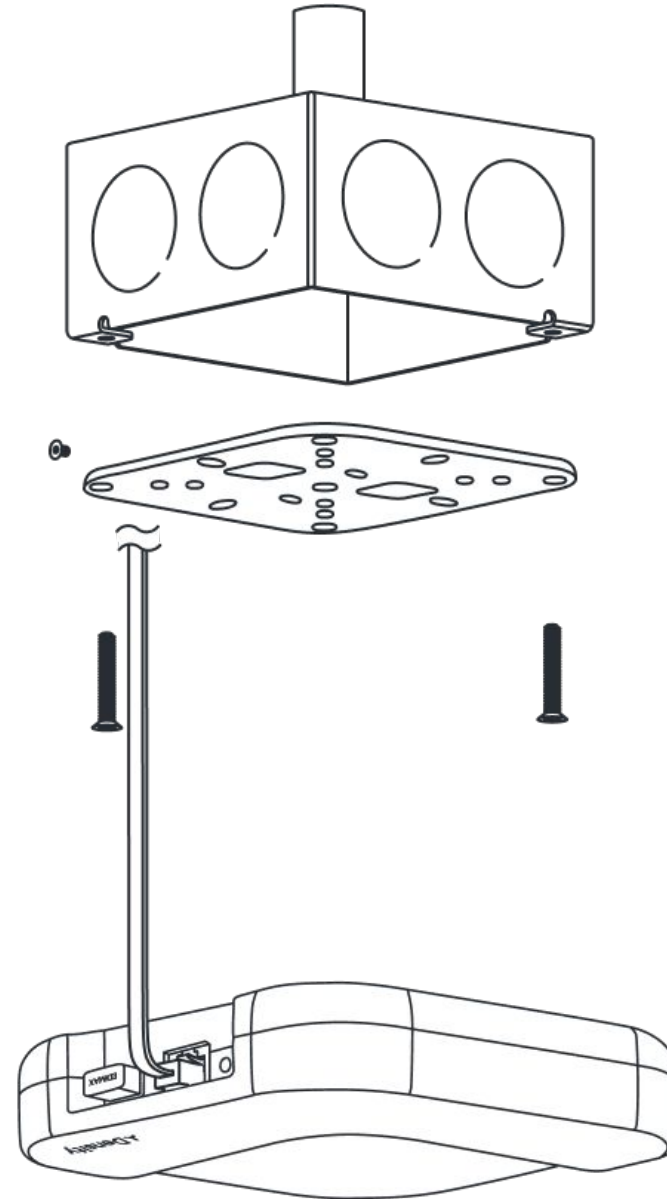
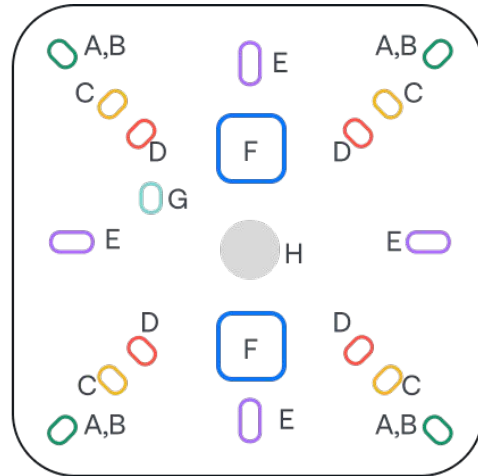

Step 1: Attach mount plate

Attach the mount plate to the junction box using the necessary screws. Make sure you have the proper screw for the desired junction box.

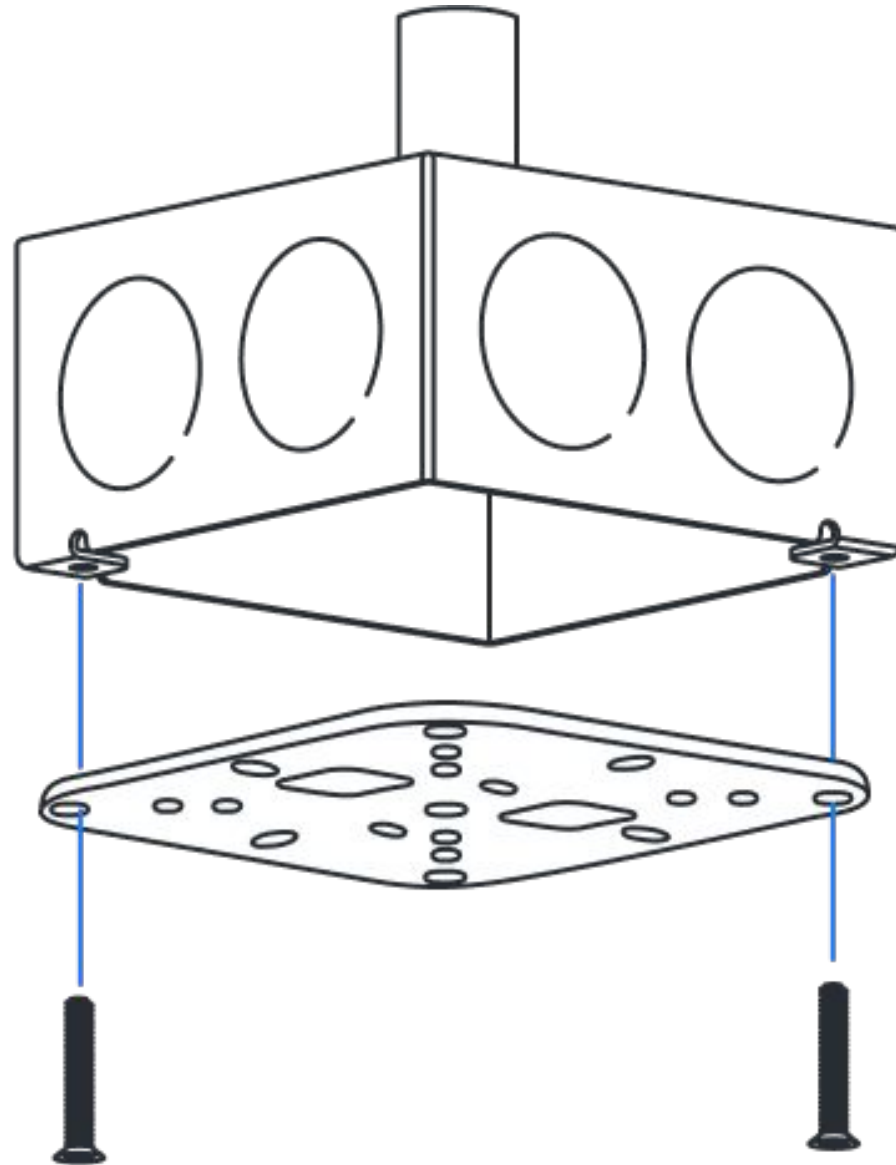

Step 2: Attach Entry LR Sensor

Attach the Entry LR Sensor to the threaded rod by inserting the threaded rod into the 1/4in-20 threads on the back of the Open Area sensor and twisting the sensor onto the rod until tight.

Screw the unit on all the way until it stops, then back it off to the prescribed location using the ethernet jack as the location guide.

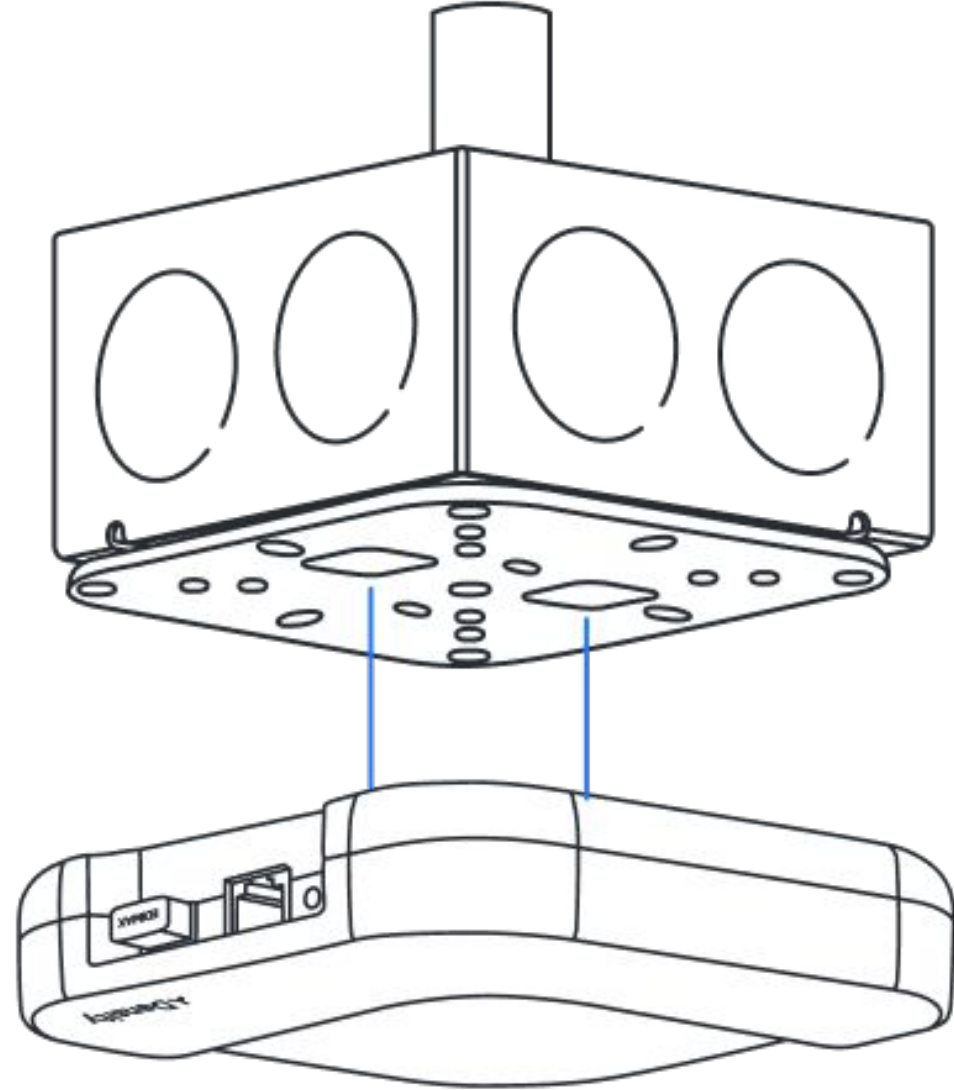
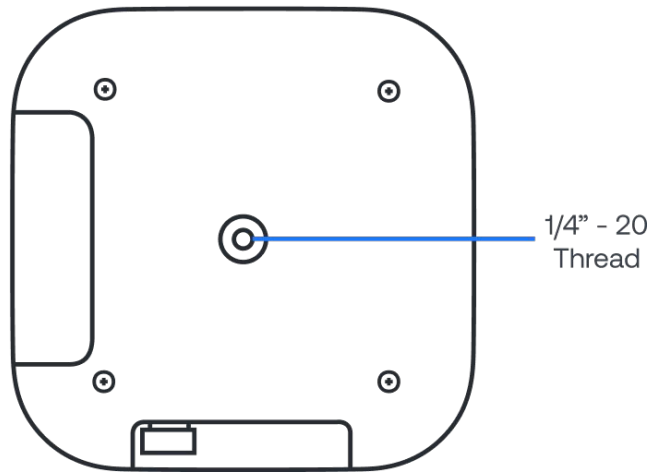

Step 3: Route cabling

The ethernet cable should be routed through the knockout holes in the junction box.

Be sure to use appropriate connectors or bushings to provide physical protection to the cable. Follow minimum bend radius requirements for the type of cable used.

