

Complete Installation Guide

Entry Long Range Sensor



Contents

01 – In the Box

02 – Hardware

03 – Power

04 – Networking

05 – Entryway Guidelines

06 – Mounting Options

07 – Ceiling Mount

08 – Wall Mount

09 – Alternate Mounting Options

In the Box

01

Product

- + Entry Long Range Sensor
(Note: The box will say Open Area Sensor)
- + Legal Information Booklet
- + Quick Start Guide

Ceiling Mount Kit

- + Mount Plate

Alternative Mounting (Available to Order)

- + Entry Long Range Wall Mount Kit
(895-0011)

Sensors

60-64GHz mmWave sensor

Environmental specifications

- + Temperature: 32°- 95°F (0°- 35°C)
- + Relative humidity: 20% to 80%
- + non-condensing
- + Rated for indoor installation only

Note: Open Area sensors can reach temperatures up to 135°F (57°C) after going online. Please keep proper ventilation in mind. If you need to handle the sensor, unplug it and wait a few minutes for it to cool down, or wear gloves so it is more comfortable to handle the device

Indicators

Multi-color status LED

Unit weight

0.78lbs (0.36kg)

Certifications

FCC Part 15 Subpart B Class A
+ Conducted Emissions (15.107)
+ Radiated Emissions (15.109)
CE Certification
UKCA Certification
ISED Certification
UL Std. No. 62368-1
IEC 60950-1:2009 Product Safety
EN 55032:2012
EN 301 489-1
RoHS2 Compliant
COO (country of origin): US
REACH Compliant
HS Code: 8471.90.0000

Dimensions & features

- + White polycarbonate enclosure
- + Powder coated aluminum base
- + Integrated 1/4"-20 mounting threads
- + Thread depth: 0.2in (0.5cm)
- + Mount plate

Interface

- + 1x 10/100/1000 BaseT RJ45 interface
- + WiFi/Bluetooth dongle
- + Reset button

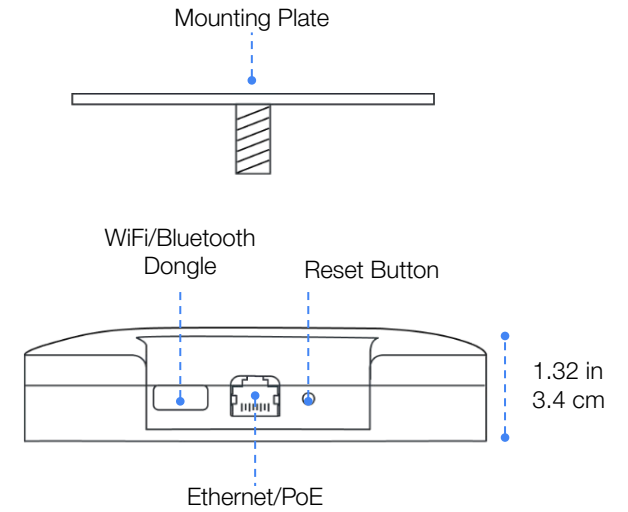
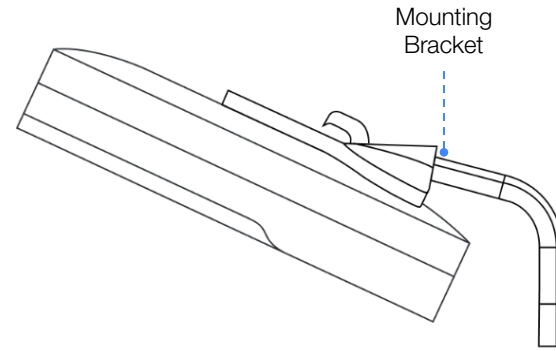

Hidden Indicator LED

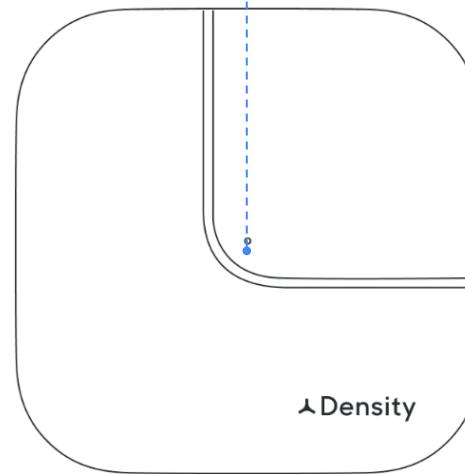

1/4 in - 20 Thread

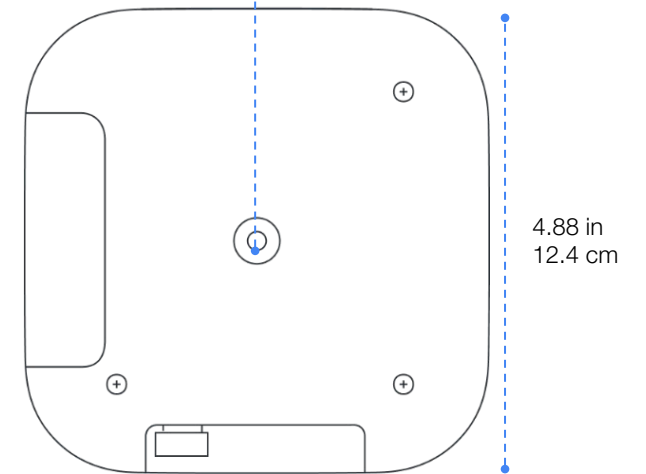

Mounting Plate

- A. Ceiling or Drop Ceiling Tile
- B. 4" Square Junction Box (US)
- C. 4" Round Junction Box (US)
- D. 3.5" Round Junction Box (US)
- E. Single-Gang Outlet Box (US)
- F. Pass Through
- G. Auxiliary Hole
- H. 1/4"-20 Threaded Stud

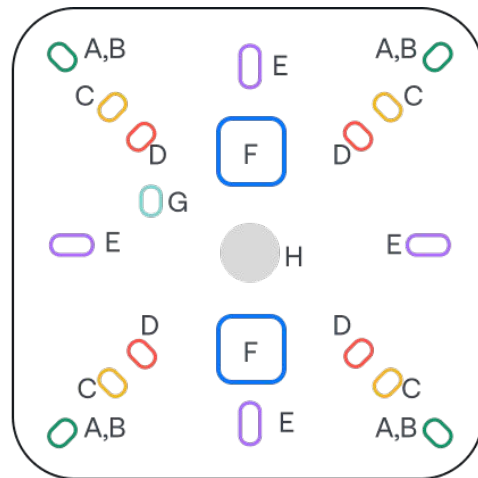

Interface

1x 10/100/1000 Base-T RJ45 interface

- + 1x USB 2.0 Port for WiFi/Bluetooth dongle
- + Reset Button

MAC address

Can be found on the side of the box that the sensor came in.

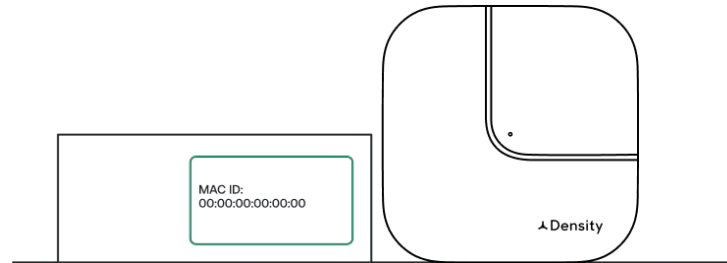

Serial Number Label

Appears on the side of the sensor.

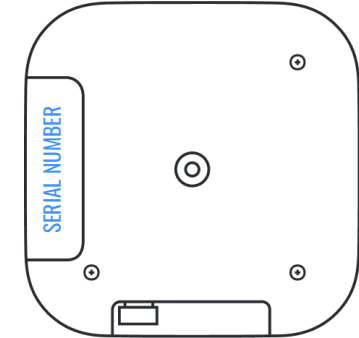

Temperature

The aluminum enclosure of the sensor is expected to be hot during operation. Density sensors comply with certification temperature requirements and do not pose any risk of burning the skin or causing fires. If the sensor has been powered on for an extended period of time, it is recommended to remove the power cable and allow the sensor to cool for at least 5 minutes before handling.

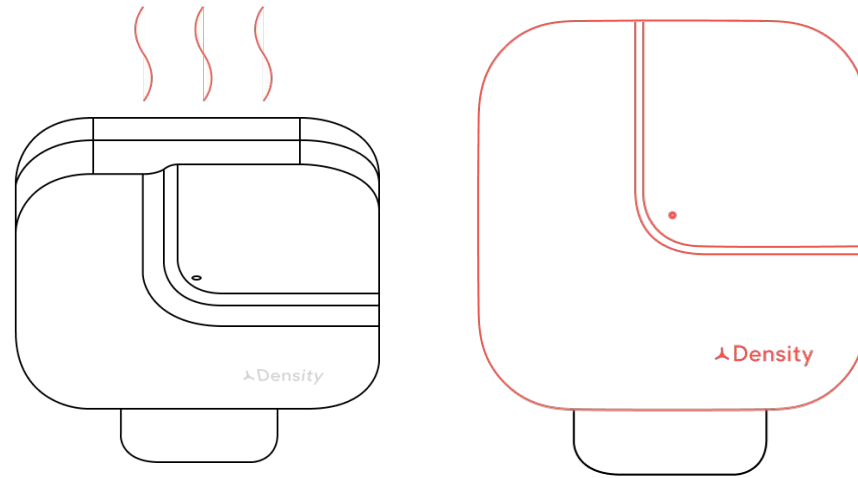

Environmental

Temperature

32°- 95°F (0°- 35°C)

Relative humidity

20% to 80% non-condensing

Rated for indoor installation only

Ingress Rating

None

Resetting the sensor

To reset the sensor to default factory settings, press and hold the reset button until the LED stops blinking (approx 10 seconds). The sensor must be plugged in and connected to power in order to reset.

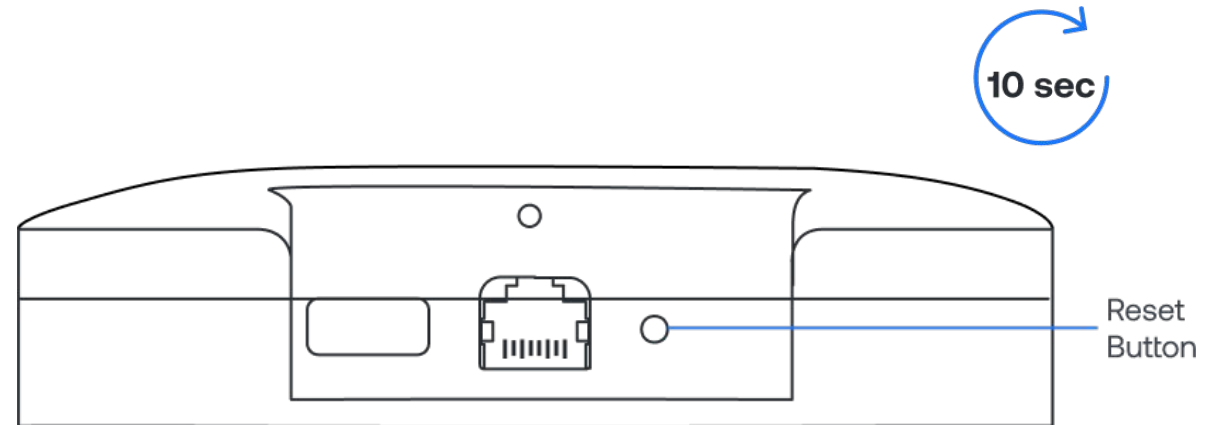

Power requirements

The Entry LR sensor can be powered by either a 802.3af PoE switch or a PoE Injector Wall Plug.



Cable requirements

The sensor requires a Cat 5e or later ethernet cable (not included). Flat white cable recommended for optimal aesthetics.

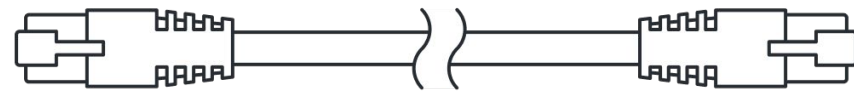

Cat 5e or later

Option 1 – PoE switch

Connect one end of a Cat 5e or later ethernet cable to a 802.3af compliant network switch capable of providing 15.4W per port. Plug the other end of the ethernet cable into the Entry LR Sensor.

Density's Entry Long Range device (model: OA1) requires PoE power to operate. You must use a PoE (802.3af) compatible switch or power injector that provides the specified 15.4W per port and be conscious not to exceed the switch load. For example, a 150W PoE switch can only host Open Area sensors assuming no other loads on that switch.

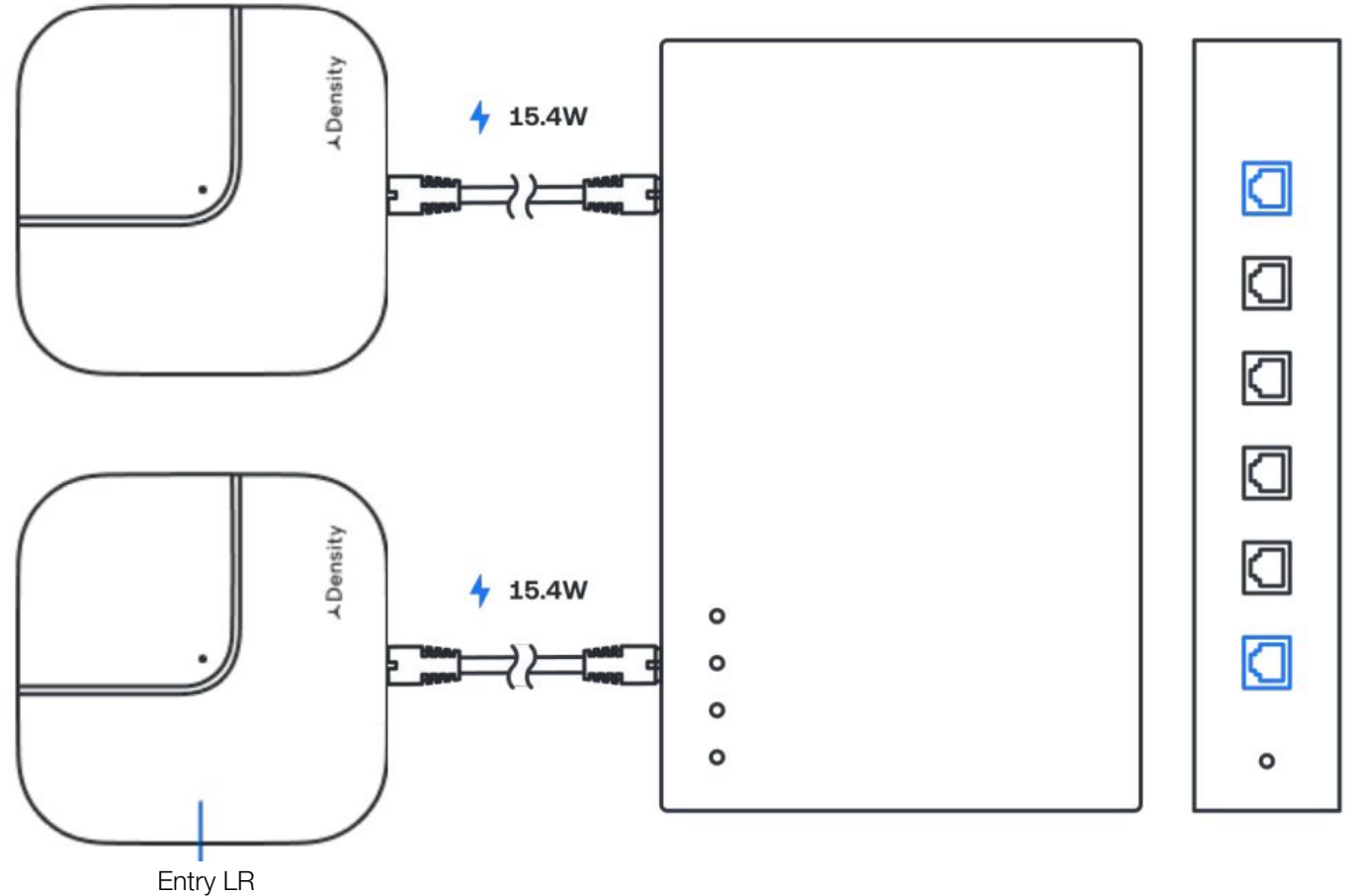

Option 2 – PoE injector using ethernet

Plug the PoE Injector into any standard 120v (US) wall outlet. Plug one end of a Cat 5e or later ethernet cable into a cradlepoint / router or non PoE switch. Plug the other end of the cable into the Data In port located on the bottom of the Injector. Plug an additional ethernet cable into the Data & Power Out port also located on the bottom of the injector. Plug the other end of the ethernet cable into the sensor.

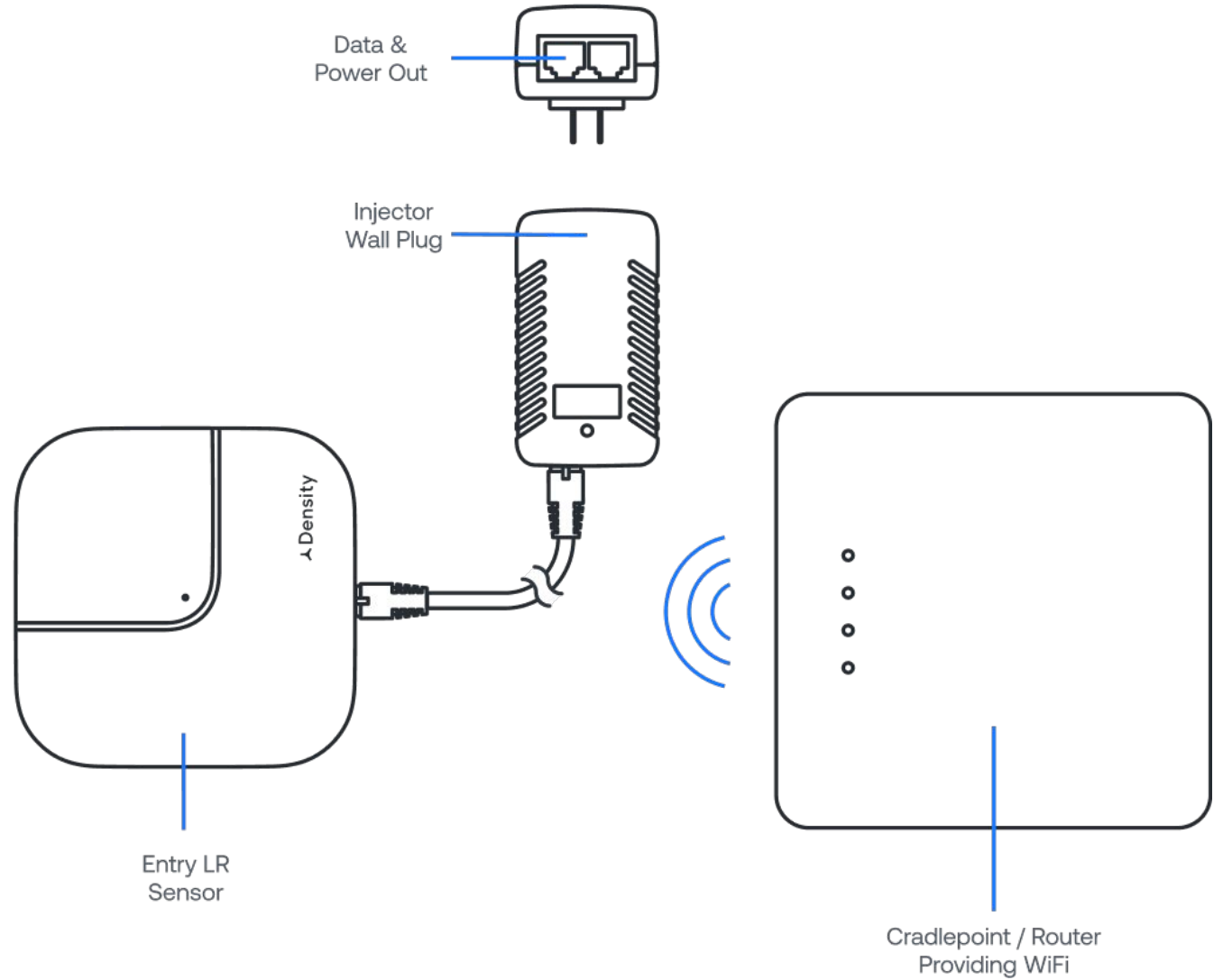

Option 3 – PoE injector using WiFi

Plug the PoE Injector into any standard 120v (US) wall outlet. Plug one end of a Cat 5e or later ethernet cable into the Data & Power Out port located on the bottom of the injector. Plug the other end of the ethernet cable into the sensor. Use the Unit Setup App to connect the sensor to a WiFi network.

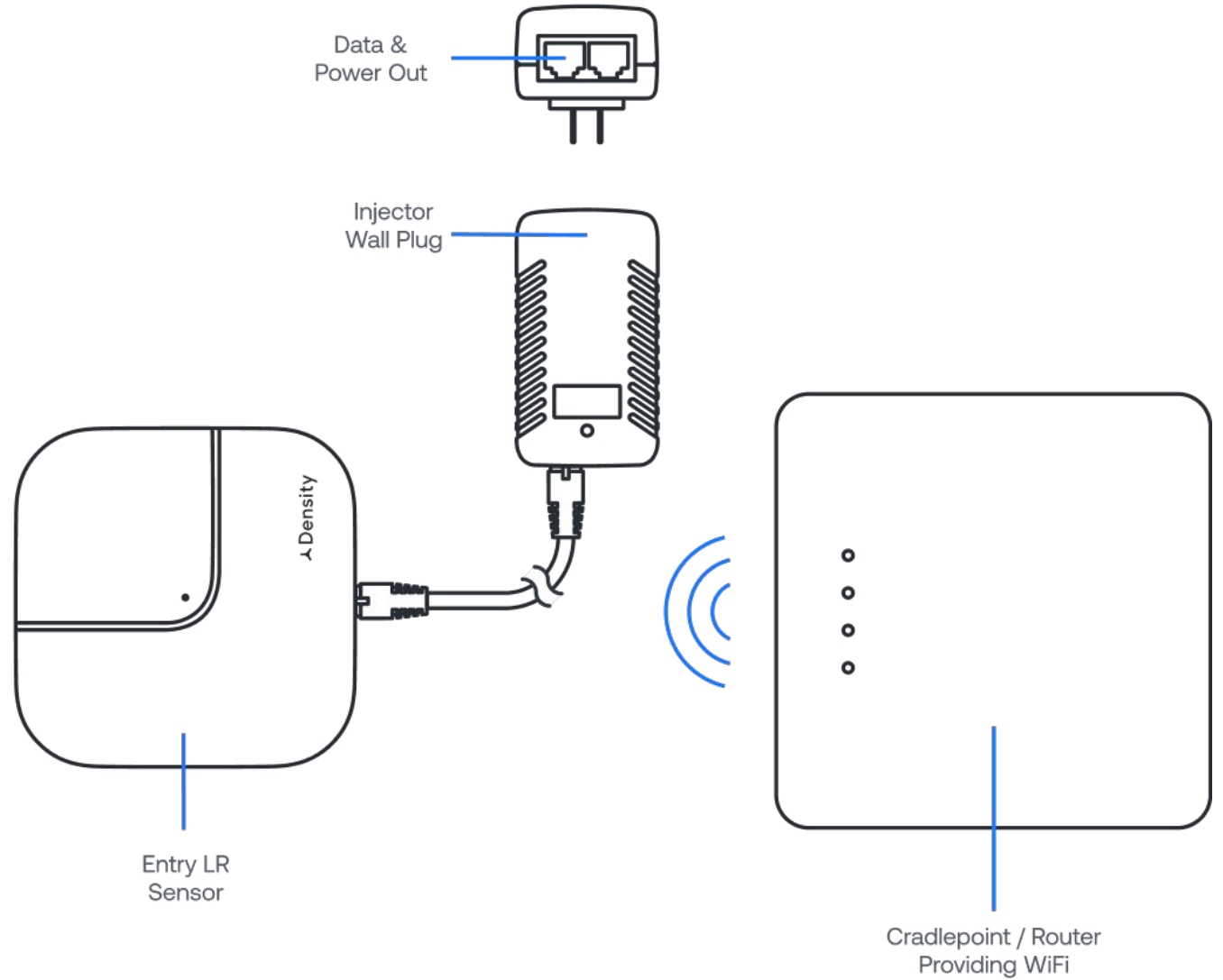

Networking basics

Density devices require internet connectivity to pass data to the web application.

Recommended Configuration: Wired ethernet connectivity configured via DHCP with internal NTP and internal DNS servers. IPv4 is required.

Networks that are not supported:

- + Captive portal
- + Proxy
- + WPA2 Enterprise
- + Hidden Networks *
- + 5GHz WiFi networks

** Hidden networks can be used if temporarily made transparent while we configure the devices.*

If you have a corporate firewall

You will need to safelist the device MAC addresses (the MAC addresses can be found on the outside of the packaging box for the device). You may also have to safelist the following addresses to ensure the device is able to communicate outside of your corporate network:

- + *.density.io (port 443)
- + *.amazonaws.com
- + *.gstatic.com
- + *connman.net
- + ntp port (port 123) must be open
- + If internal DNS is not available then external DNS servers 8.8.8.8 and 8.8.4.4 will be used and port 53 must be open

Density does not currently support IP address safelisting. A list of exact API subdomains is available by request.

Setup App

Used to configure and troubleshoot units. iOS and Android application available - Go to mobile.density.io to download.

Sensor LED status indicator

The sensor has an indicator LED located on the front of the sensor. The color chart below explains the meaning of each color, defines any issues, and lists what actions to take if necessary.

If the recommended action does not resolve the LED light error status, factory reset the sensor. To reset, press and hold the reset button on the side of the sensor until the LED light starts flashing white. If the issue persists, please reach out to support@density.io.

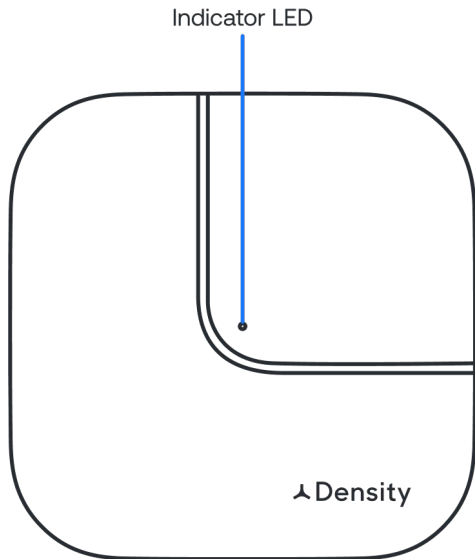

Color	Pattern	Visual	Meaning	Description/Action
No Light	No Light	•	Sensor is not receiving power	Check that sensor is plugged in and receiving power from the source
White	Solid	•	Operating Normally	No action needed
White	Flashing	• • •	Locate sensor function	Indicates which sensor you're interacting with when using "Locate" in the mobile app
Blue	Solid	•	Ready to be Provisioned	Typical state out of the box once sufficient power is provided.
Blue	Flashing	• • •	Connected to Bluetooth	No action needed FYI: LED blinks while the app is connected to the sensor
Orange	Solid	•	Factory OS	Contact support@density.io with serial numbers
Orange	Flashing	• • •	Low Power Mode	Confirm switch is PoE+ with at least 16W of power per port. Test ethernet cables.
Purple	Solid	•	Sensor cannot connect to the Density Server	Provision sensor via mobile app (mobile.density.io). If not resolved, run "Validate" in app and email results to support@density.io
Purple	Flashing	• • •	Server cannot connect to DNS	Verify DNS is available on VLAN. If no internal DNS server, review corporate firewalls to verify device can reach default DNS servers
Red	Solid	•	No Network Configuration	WiFi: Use the Spaces app to create a network template Ethernet: Verify DHCP server is available on VLAN
Red	Flashing	• • •	No Dongle Present or No ToF (reserved)	Occurs when device has not yet been provisioned and the Bluetooth Dongle is absent. Plug in Bluetooth Dongle to provision.

Number of Sensors

To maintain an accurate count of a space, you need to install a sensor above every entryway to that space. The sensor is designed for indoor use only.

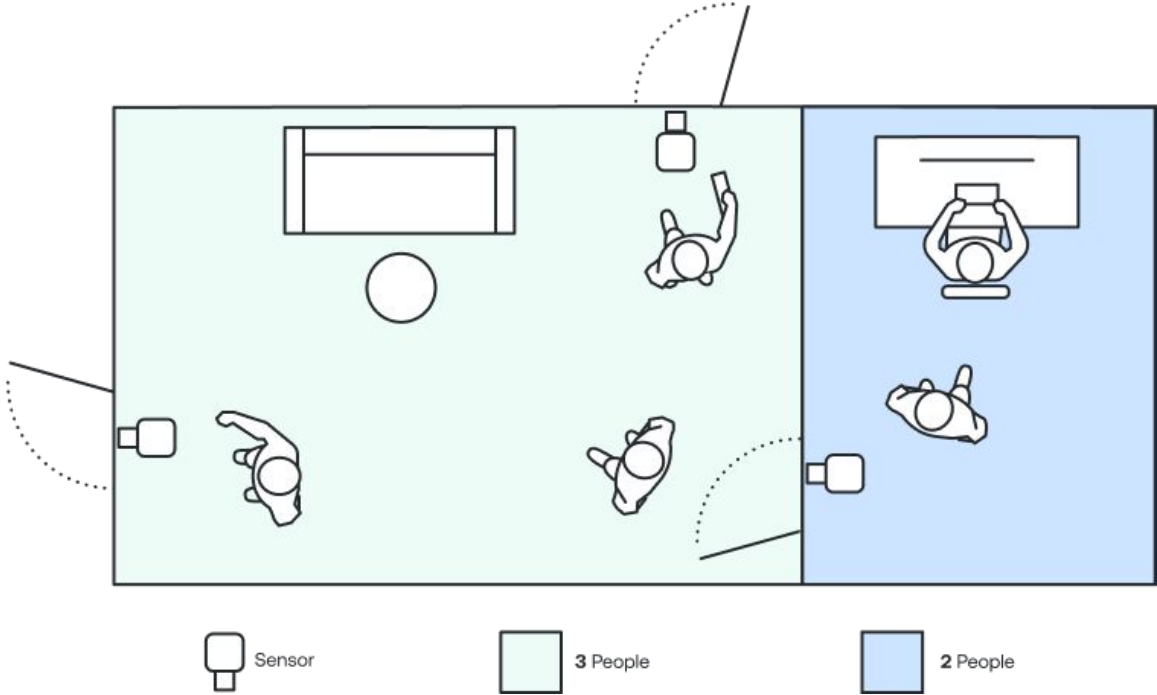

Sensor Height

Adequate sensor height is critical to ensure proper field of view (FOV) coverage of the entryway. The Sensor Height is determined by measuring the distance between the LED of the sensor and the ground. The Wall Bracket Height is the distance between the bottom of the wall bracket and the floor.

Sensor Height can be determined for wall-mounted installations by measuring the Wall Bracket Height and adding 1.3 in (3.25 cm) to that measurement.

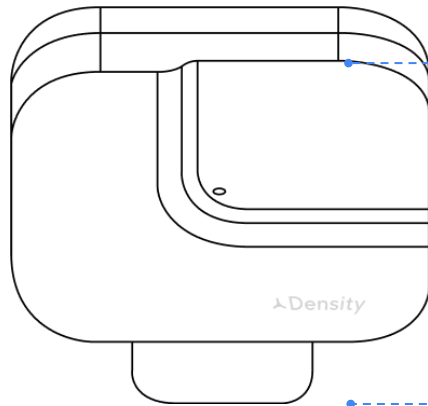
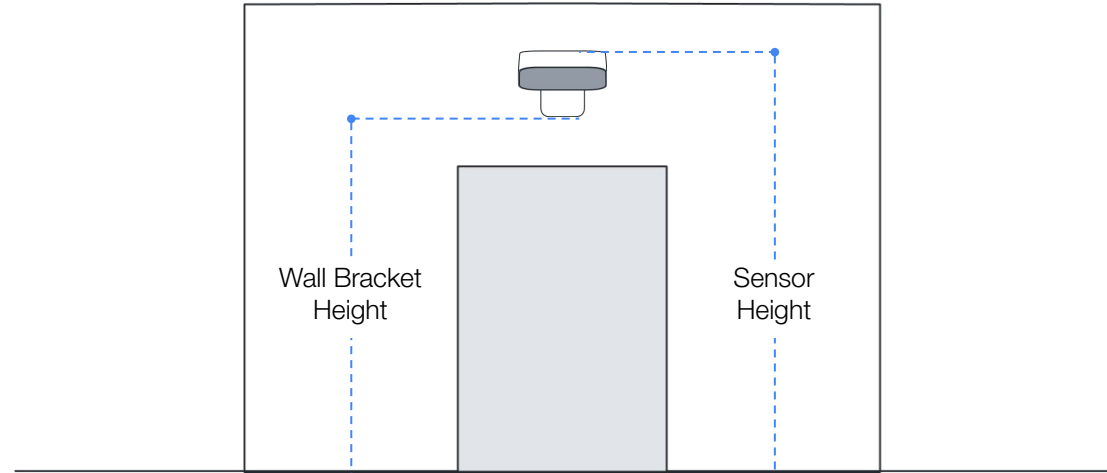

Sensor Height (Install Height)

Max height - 128in (325cm)

Min height - 78in (200cm)

Wall Bracket Height

Max height - 127in (321.75cm)

Min height - 77in (196.75cm)

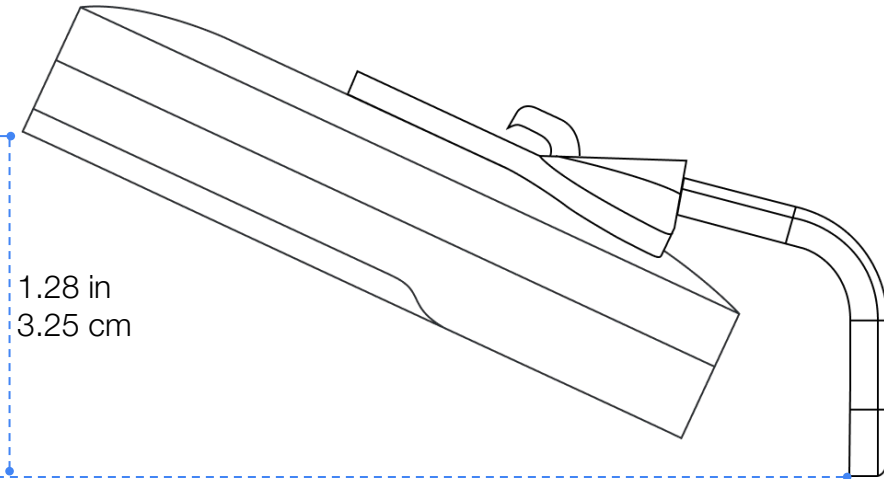

Threshold

People are counted as they cross the threshold. A threshold can be a physical doorway or virtually created at a given traffic chokepoint.

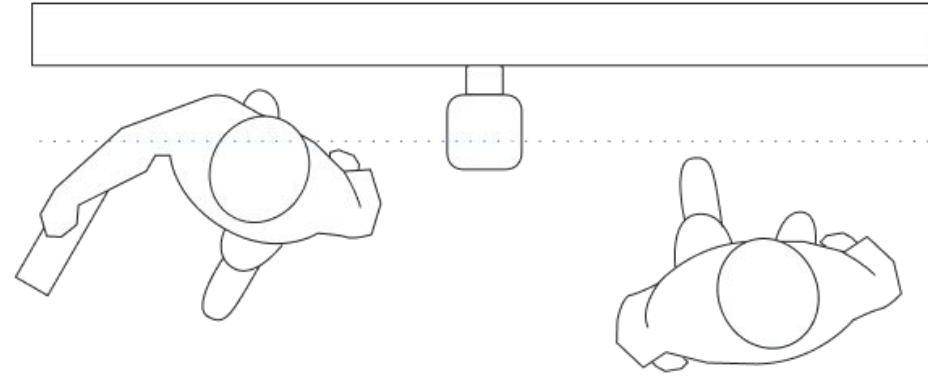

Sensor Install Height

- Ideal range: 88-118 in (2.25 - 3.0 meters)
- Absolute Minimum: 79 in (2.0 meters)
- Absolute Maximum: 128 in (3.25 meters)

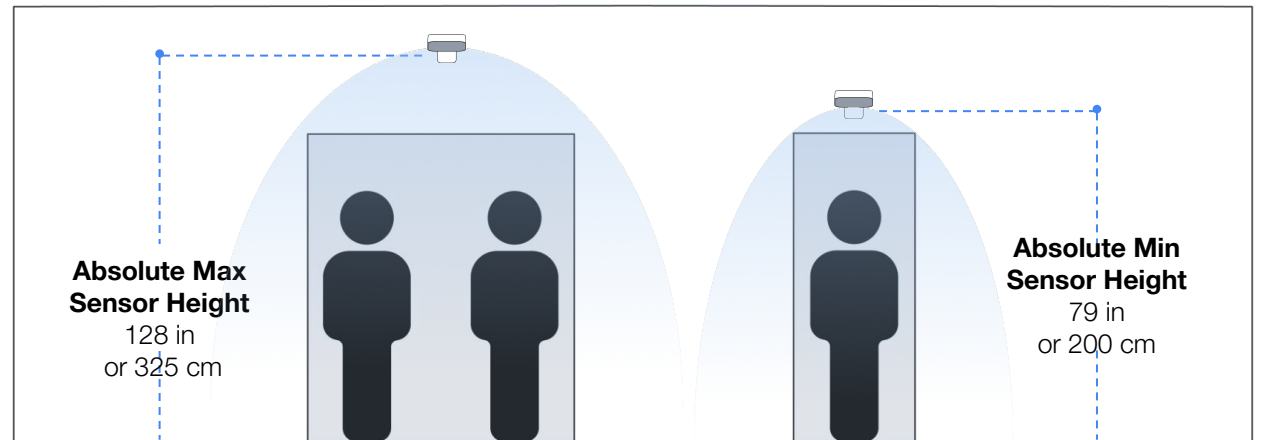

Threshold Width

To determine the Threshold Width of the entryway, measure the open space a person can physically walk through. Measure frame to frame for doorways and wall to wall for hallways.

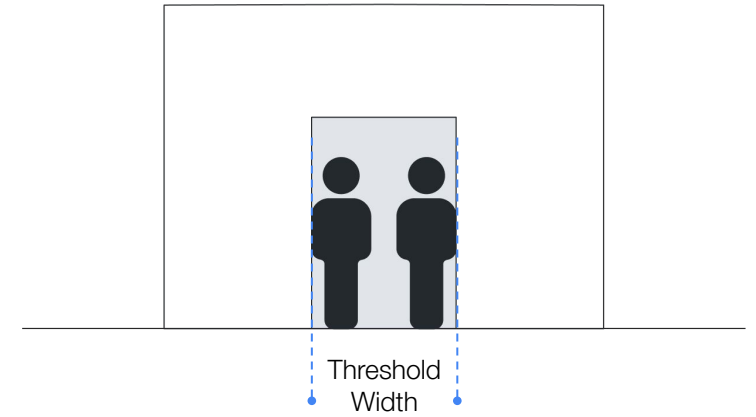
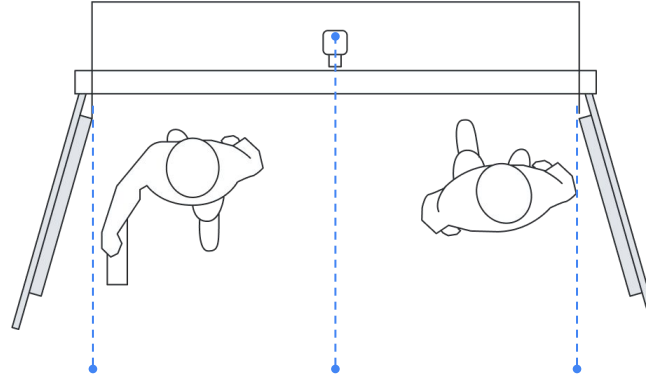

Sensor Orientation When Wall-Mounted

The sensor must be positioned parallel to the flow of traffic through the entryway. The sensor should point away from the wall if mounted near an entryway.

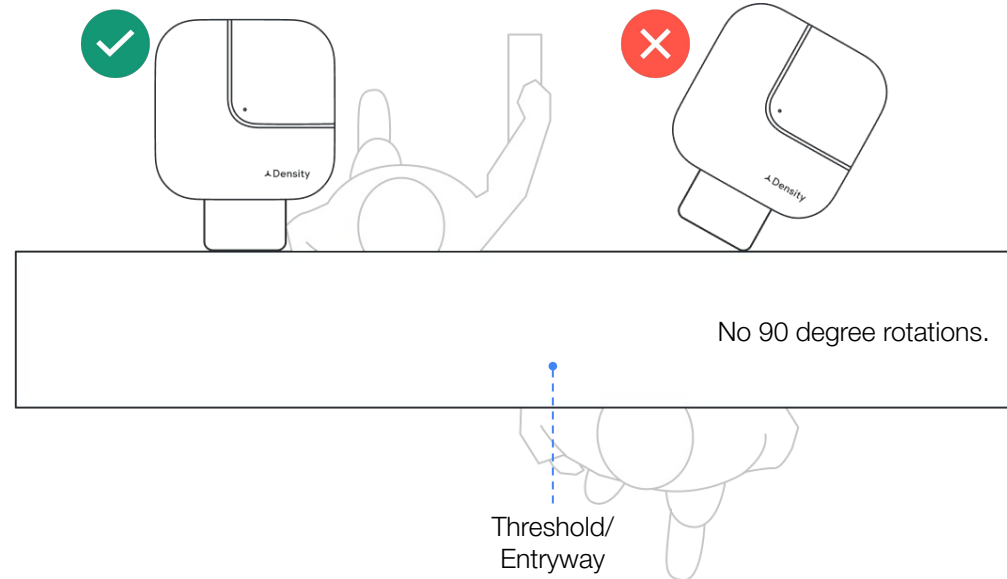

What's a Single-Sided Threshold Width?

A Single-Sided Threshold width is the along-the-wall distance from the center of the device to the edge of the threshold.

You can measure to either edge of the threshold. In practice, a device is limited by the side farthest from the edge of the threshold. There is only a maximum spec, not a minimum distance to the threshold edge.

The maximum single-sided threshold width is how far a sensor can be from the threshold edge before it won't be able to count all ingress and egress accurately. The sensor can accurately count as long as the dotted line is within the max width.

Here's an example of a sensor placement that is too far from the center as it can go and is too far from the farthest threshold edge.

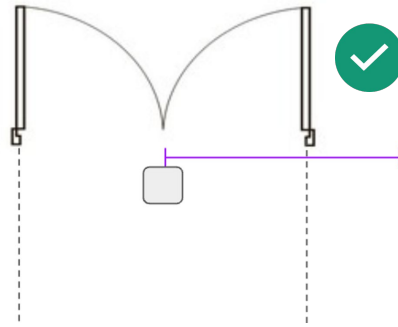

Max Single Sided Threshold Width

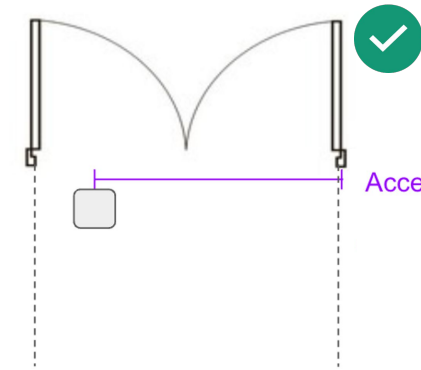

Acceptable Sensor Location

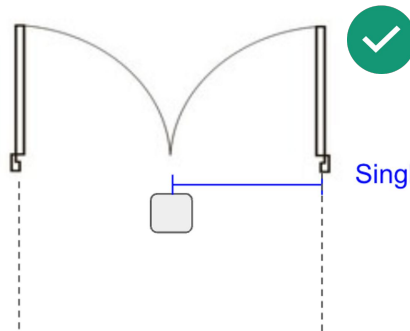

Single Sided Threshold Width

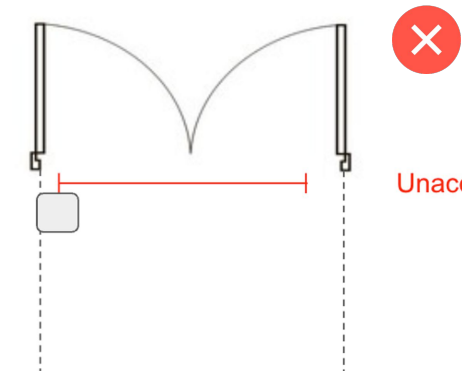

Unacceptable Sensor Location

Sensor Placement

Sensors must be placed such that they fall within the minimum and maximum install height measurements.

Sensors must also fall within the single-sided threshold width recommendations based upon sensor height.

Sensor height	Max Single-Sided Threshold Width	Max Threshold Width (Center-Mounted Sensor)
79 in - 88 in (2.0m - 2.25m)	39 in (1.0m)	78 in (2.0m)
88 in - 128 in (2.25m-3.25m)	59 in (1.5m)	118 in (3.0m)

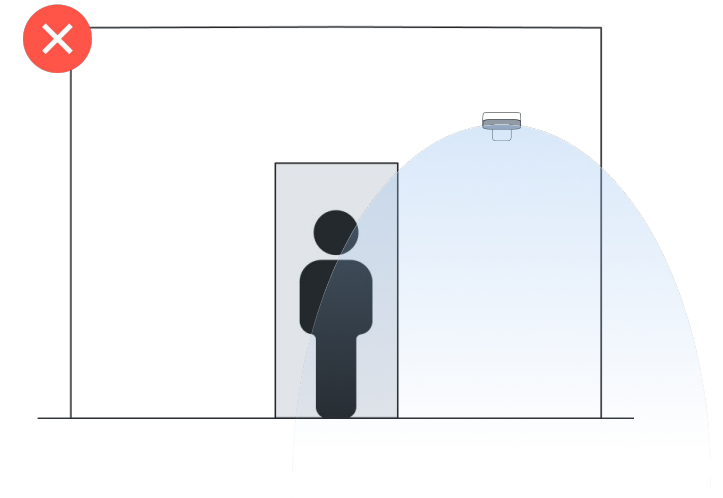
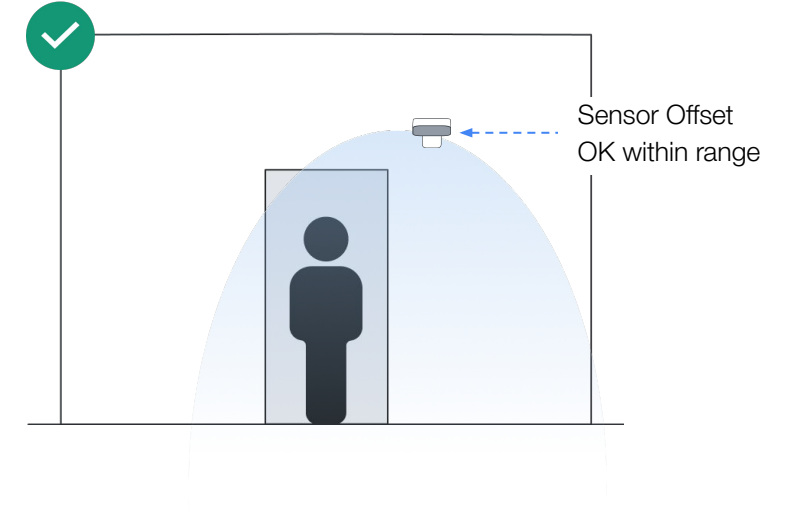
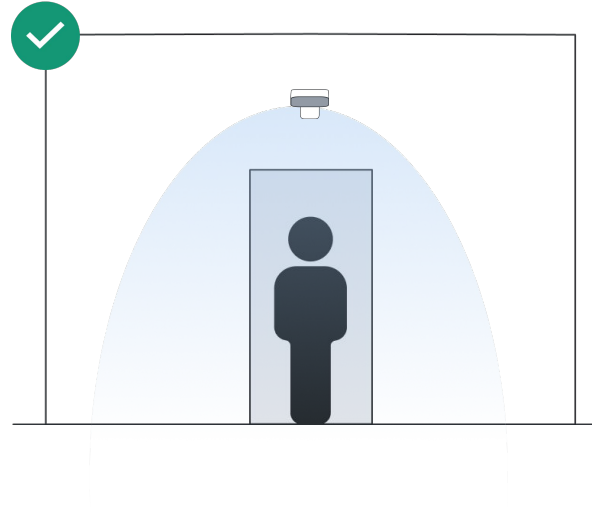

Sensors Over Swinging Doors

When at all possible, **sensors should be placed on the non-swinging side of the threshold.**

A ceiling mounted sensor is preferable compared to a wall mounted sensor over a swinging door.

Before mounting a sensor above a swinging door, consider alternate traffic choke points where a ceiling mounted unit may be more successful (see example). Please note, ELR thresholds are not required to be physical doorways and can be created virtually anywhere within the fov of the sensor.

In the unlikely event that a sensor is placed above a swinging door, sensors must have at least 10in clearance between the sensor and the door.

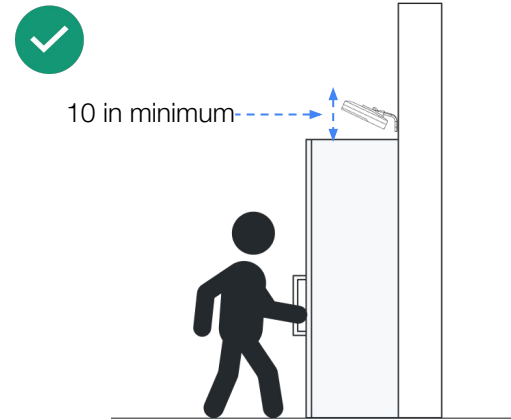

Sensor Positioning

When mounting the sensor to the ceiling, make sure that the sensor is not mounted too close or too far away from the entryway/threshold. The optimal position for the threaded rod is 12 - 30 in (31 - 76 cm) away from the threshold/entryway.

The minimum distance away from the threshold/entryway is 3.5 in (9 cm).

In some cases, obstructions or other environmental issues may call for the sensor to be installed outside these guidelines. Any deviation from the guidelines should be under the direct consultation of an account representative.

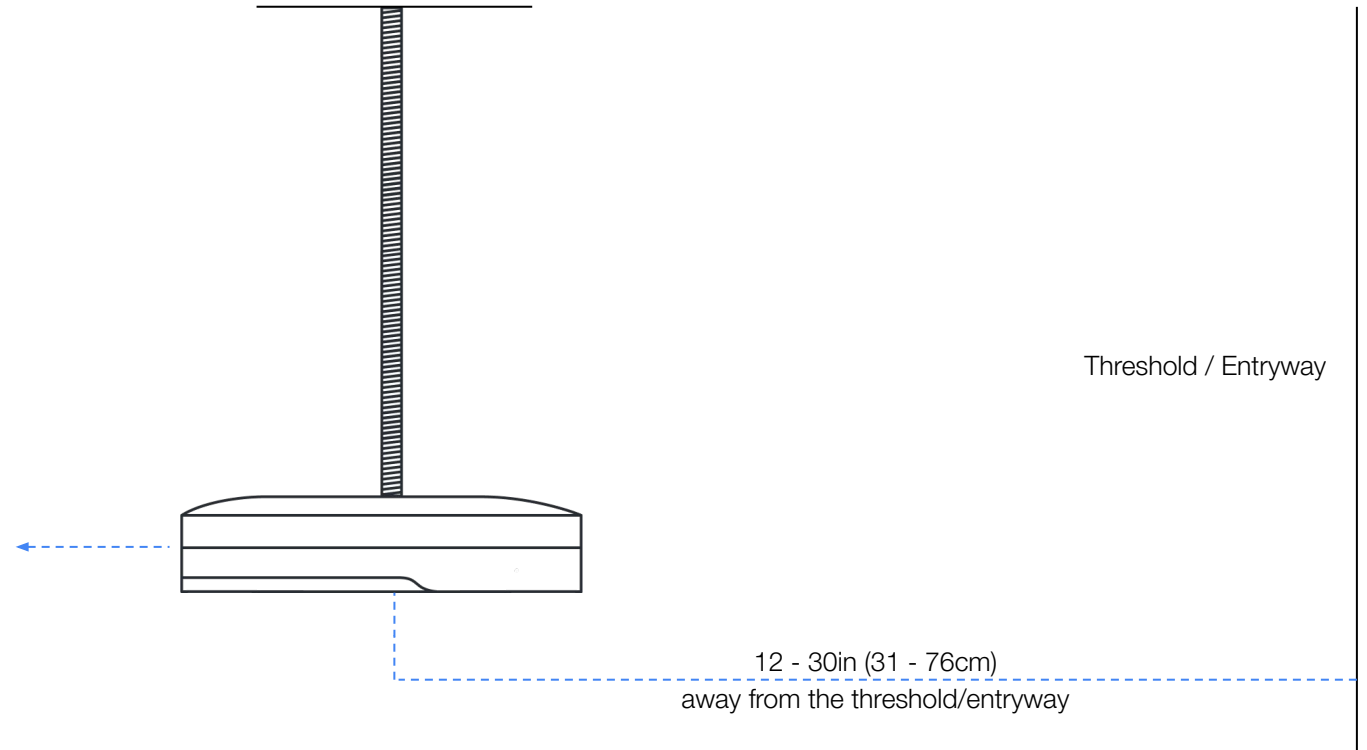

Exit Signs

Exit signs should be level with the front edge of the sensor or higher to avoid any light or FOV interference. If the exit sign is level with the sensor's front edge, ensure at least 6 in (15 cm) of space between the exit sign and the wall.

If an exit sign position falls outside these guidelines, reach out to your account representative to verify that there is no FOV or light interference.

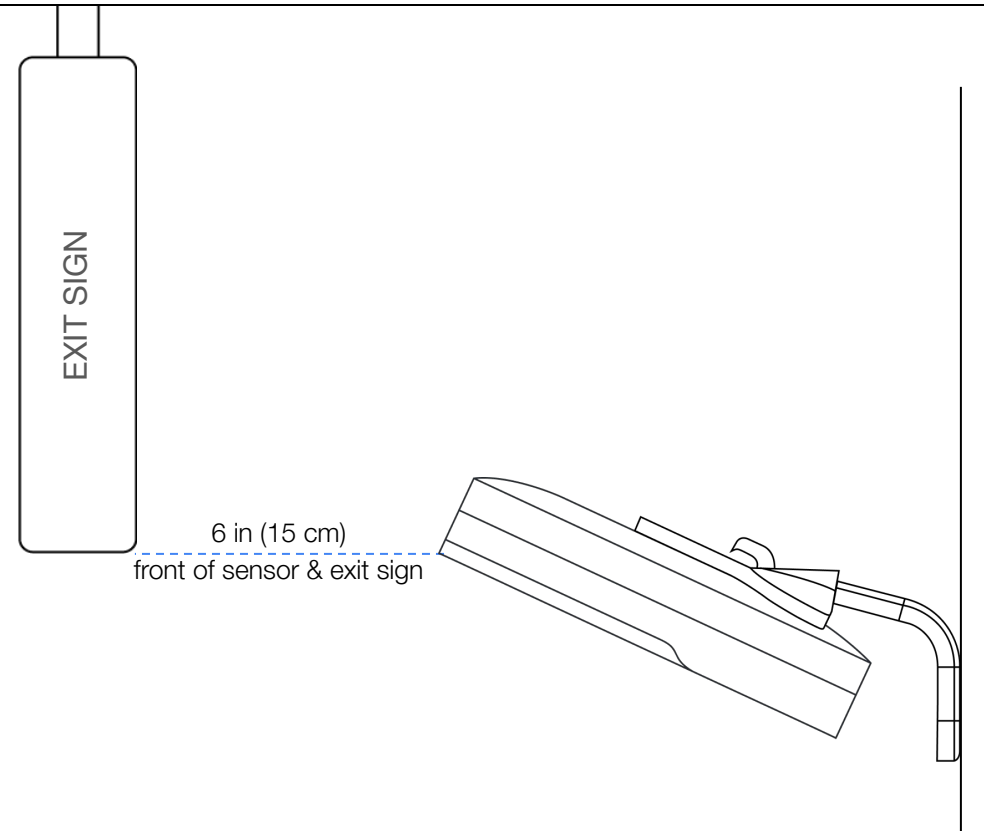

Door Frames

Installing the sensor near a door frame can cause potential FOV interference. If your installation requires a door frame mount (section 9,10), position the sensor towards the front edge of the door frame.

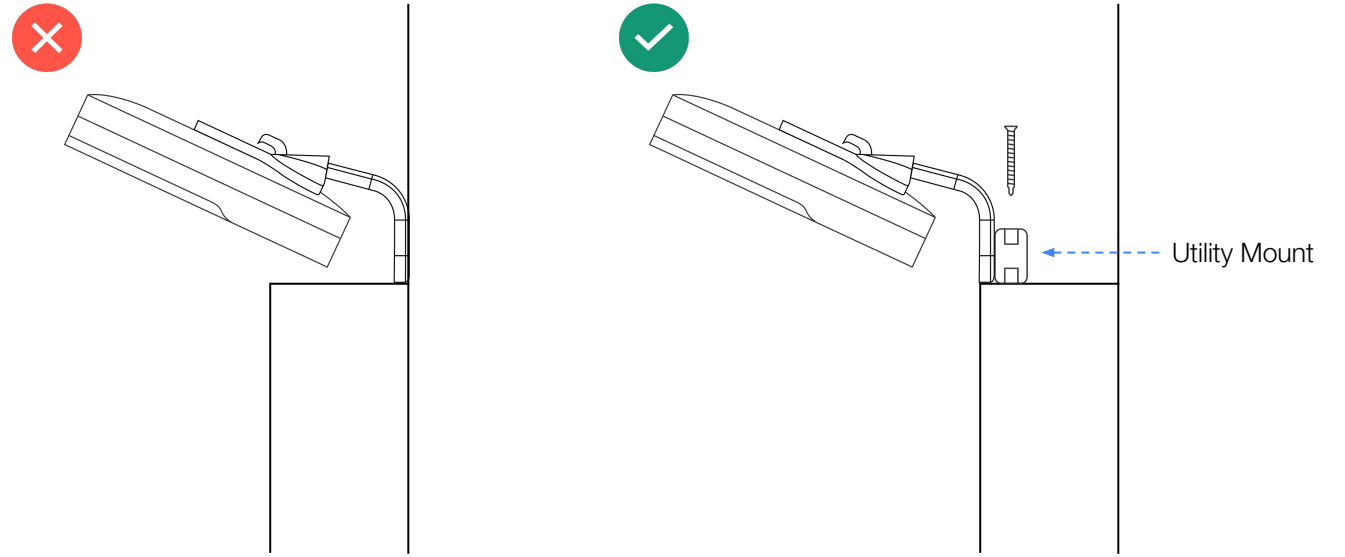

Door Swing

The sensor should be mounted on the non-door swing side of the entryway when possible. Again, consider locations for virtual thresholds on the floorplan that aren't necessarily tied to a doorway.

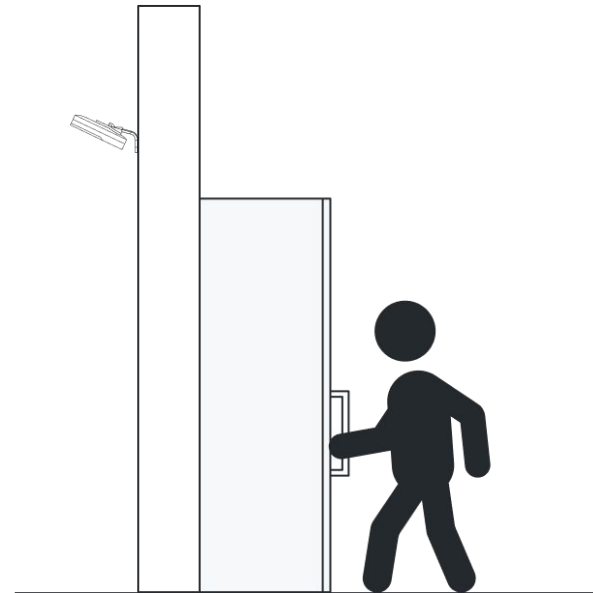

Single Door Specifics

For some single doors, the optimal sensor placement is closer to the handle side of the door. Mount the sensor approximately 10 in (25.4 cm) away from the handle side of the door if your single door meets any of the below criteria:

- + The ideal sensor height range is 88-118 in (225-300 cm)
- + The max sensor height is 128 in (325 cm) or less
- + A door closer swings under the sensor

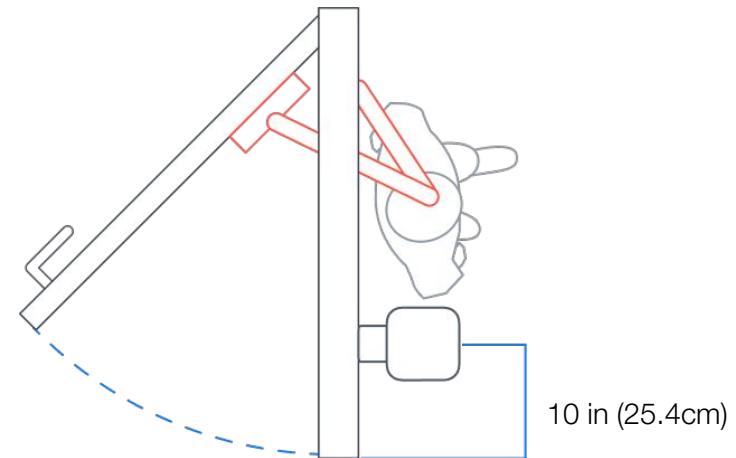
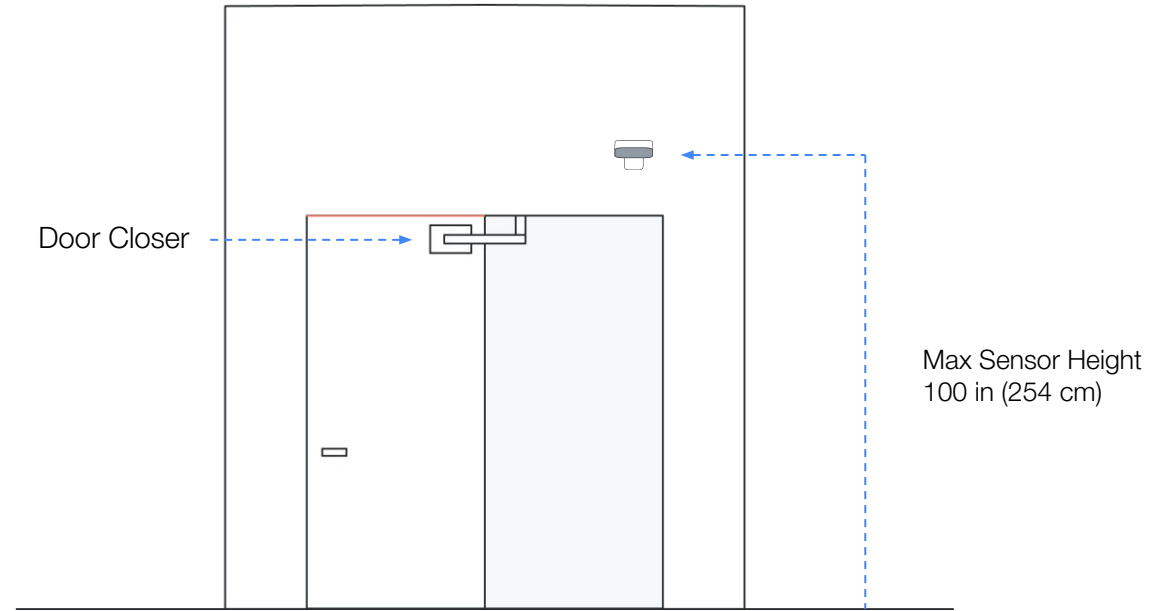

Minimum Clearance

For wall mounted installation, the minimum gap from the bottom of the bracket to the ceiling is 4 3/8 in (12 cm). This gap will guarantee the device can be slipped onto the cleat effectively.

The sensor cannot hang below the entryway for ceiling mount installations if the door swings toward the sensor, as the door will make contact. If the door swings toward the sensor, the sensor must be offset away from the door (see Door Swing Offset section).

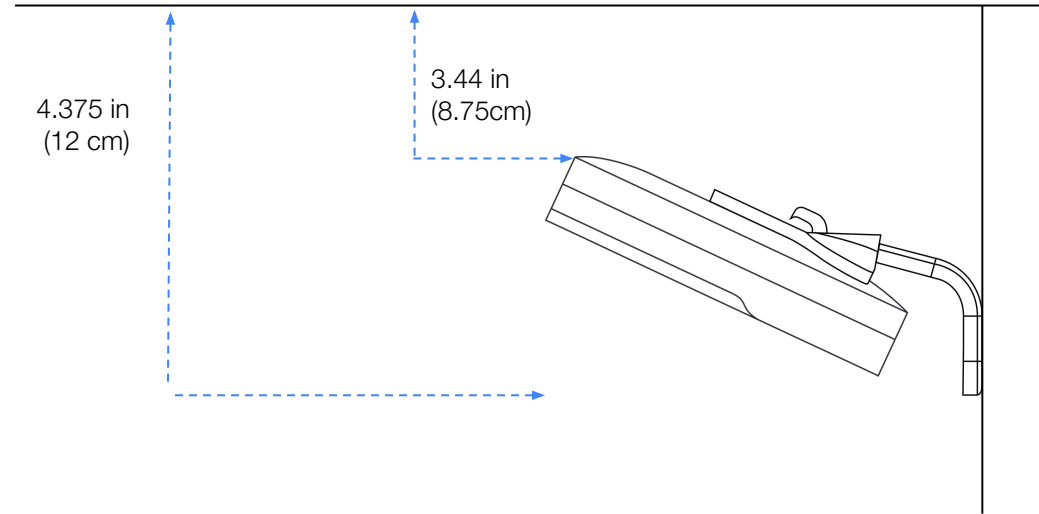

Hallways

Sensors can be suspended over hallways using a threaded rod and a Ceiling Mount Kit (section 10 and 7).

Make sure to follow the Install Height Chart for hallway installs.

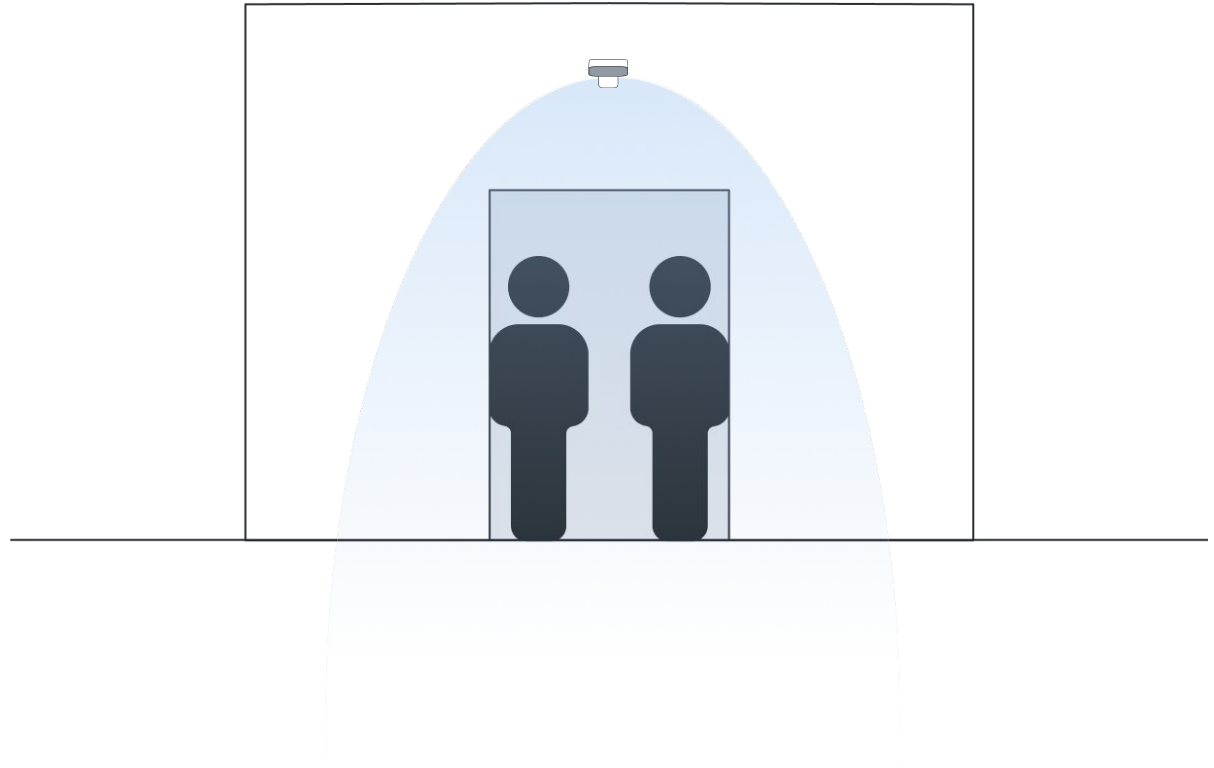

Multiple Sensors

If the entryway width is too wide and the sensor cannot be mounted high enough for ample FOV coverage, additional sensors can be added.

As shown below, multiple sensors should be mounted in line and parallel to each other.

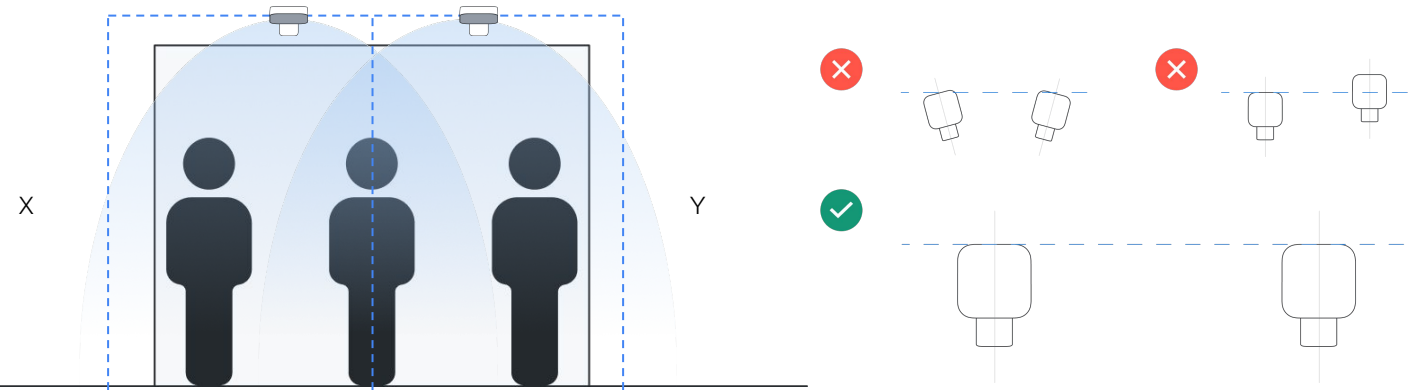

Multi-Unit Spacing - Two Sensors

For two-sensor installs, the distance between the center point of the entryway and the center point of the left and right sensors should be equal ($a = b$). The distance from the ground to the sensors should also be equal ($x = y$). In the event that equal distances are not possible, please refer to the spacing chart in the following sections to appropriately place the sensors.

Record the distance between sensor center points, sensor height, and both sensor serial numbers.

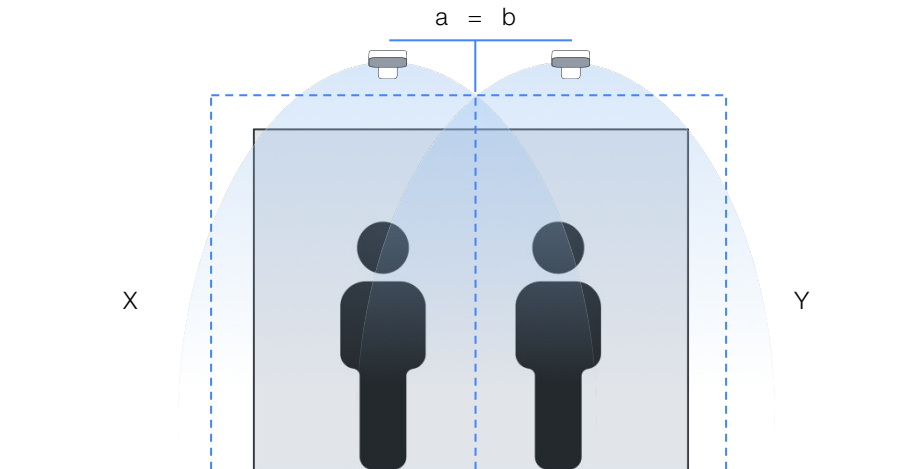

Install Height / Spacing Chart - Two Sensors

The Install Height / Spacing Chart lists the minimum sensor height requirements for various threshold widths as well as the required distance between sensors.

To use the chart, measure the threshold width (the physical opening a person can walk through), then look at the chart for the minimum required install height. Space the sensors over the threshold according to the Distance Between Sensors section of the chart. The minimum allowable distance between sensors is 39 in (99.1cm), and the maximum allowable distance between sensors is 118 in (299.7cm).

If needed, please contact your account representative for a walk-through of the Install Height / Spacing Chart.

THRESHOLD WIDTH [IN]	MIN SENSOR DIST. [IN] "NORMAL" ORIENTATION	MAX SENSOR DIST. [IN] "NORMAL" ORIENTATION	MIN SENSOR DIST. [IN] "ROTATED" ORIENTATION	MAX SENSOR DIST. [IN] "ROTATED" ORIENTATION
118	39	100	39	118
128	39	100	39	118
138	39	100	39	118
148	39	100	39	118
157	39	100	39	118
167	47	100	39	118
177	59	100	39	118
187	67	100	39	118
197	79	100	39	118
207	87	100	39	118
217	98	100	39	118
226			39	118
236			39	118
246			47	118
256			59	118
266			67	118
276			79	118
285			87	118
295			98	118
305			106	118

Install Height / Spacing Chart - Three Sensors

The Install Height / Spacing Chart lists the minimum sensor height requirements for various threshold widths as well as the required distance between sensors.

To use the chart, measure the threshold width (the physical opening a person can walk through), then look at the chart for the minimum required install height. Space the sensors over the threshold according to the Distance Between Sensors section of the chart. The minimum allowable distance between sensors is 47 in (119.4 cm), and the maximum allowable distance between sensors is 118 in (299.7cm).

THRESHOLD WIDTH [IN]	MIN SENSOR DIST. [IN] "NORMAL" ORIENTATION	MAX SENSOR DIST. [IN] "NORMAL" ORIENTATION	MIN SENSOR DIST. [IN] "ROTATED" ORIENTATION	MAX SENSOR DIST. [IN] "ROTATED" ORIENTATION
217	47	100	39	118
226	51	100	39	118
236	55	100	39	118
246	63	100	39	118
256	67	100	39	118
266	71	100	39	118
276	75	100	39	118
285	79	100	39	118
295	87	100	47	118
305	91	100	51	118
315	94	100	55	118
325	98	100	59	118
335			67	118
344			71	118
354			75	118
364			79	118
374			87	118
384			91	118
394			94	118
404			98	118
413			102	118
423			110	118
433			114	118

Common Mounting Options

06

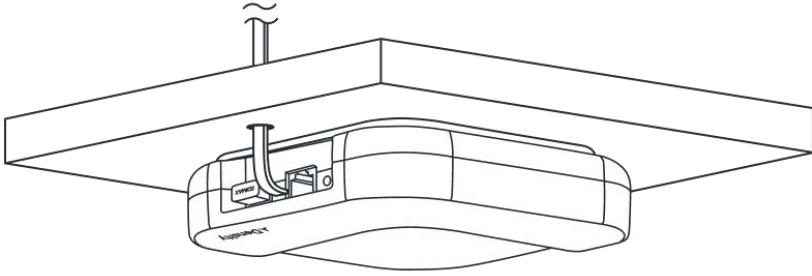

Standard Ceiling Mount

The Ceiling Mount is used for mounting the sensor flush to the ceiling in front of the entryway.

*Note - anchors and screws are not included



Wall Mount (Available to Order)

The Standard Wall Mount is used for mounting the sensor to various wall types using the provided multi-surface wall anchors and screws.

Ceiling Mount

07

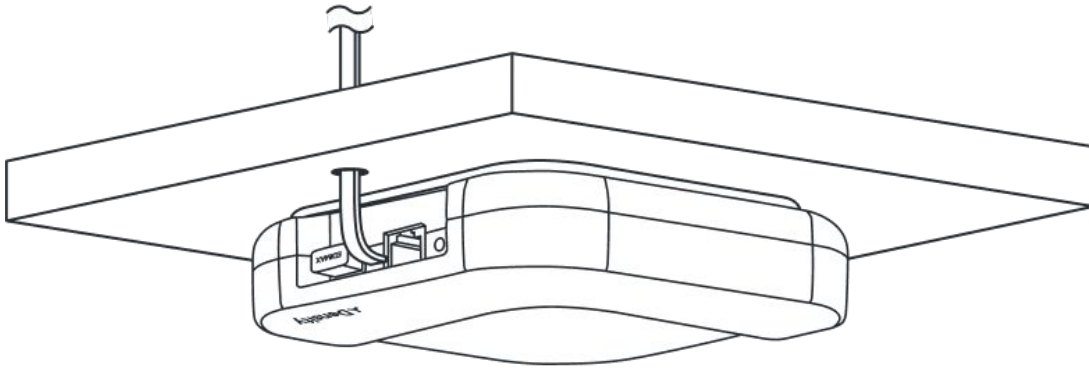

Ceiling Mount

+ Mount Plate

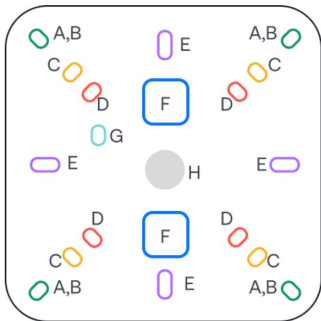

Materials NOT included

- + 4pcs #8 x 1.25in flat head screws
- + 4pcs multi-surface anchors
- + Mallet
- + Drill
- + 3/4in drill bit
- + 3/16in drill bit
- + 1/8in drill bit
- + Ethernet cable (Cat 5e or later)
- + Level

Power & connectivity

All sensors require power over ethernet and internet connectivity.

Ceiling mount plate assembly

The ceiling mount plate can be mounted to solid or hollow ceiling surfaces using the screws and anchors. Please use anchor appropriate for ceiling type.

Position mount bracket on the ceiling in the prescribed location, with one of the square slots pointing in the direction the ethernet jack needs to point.

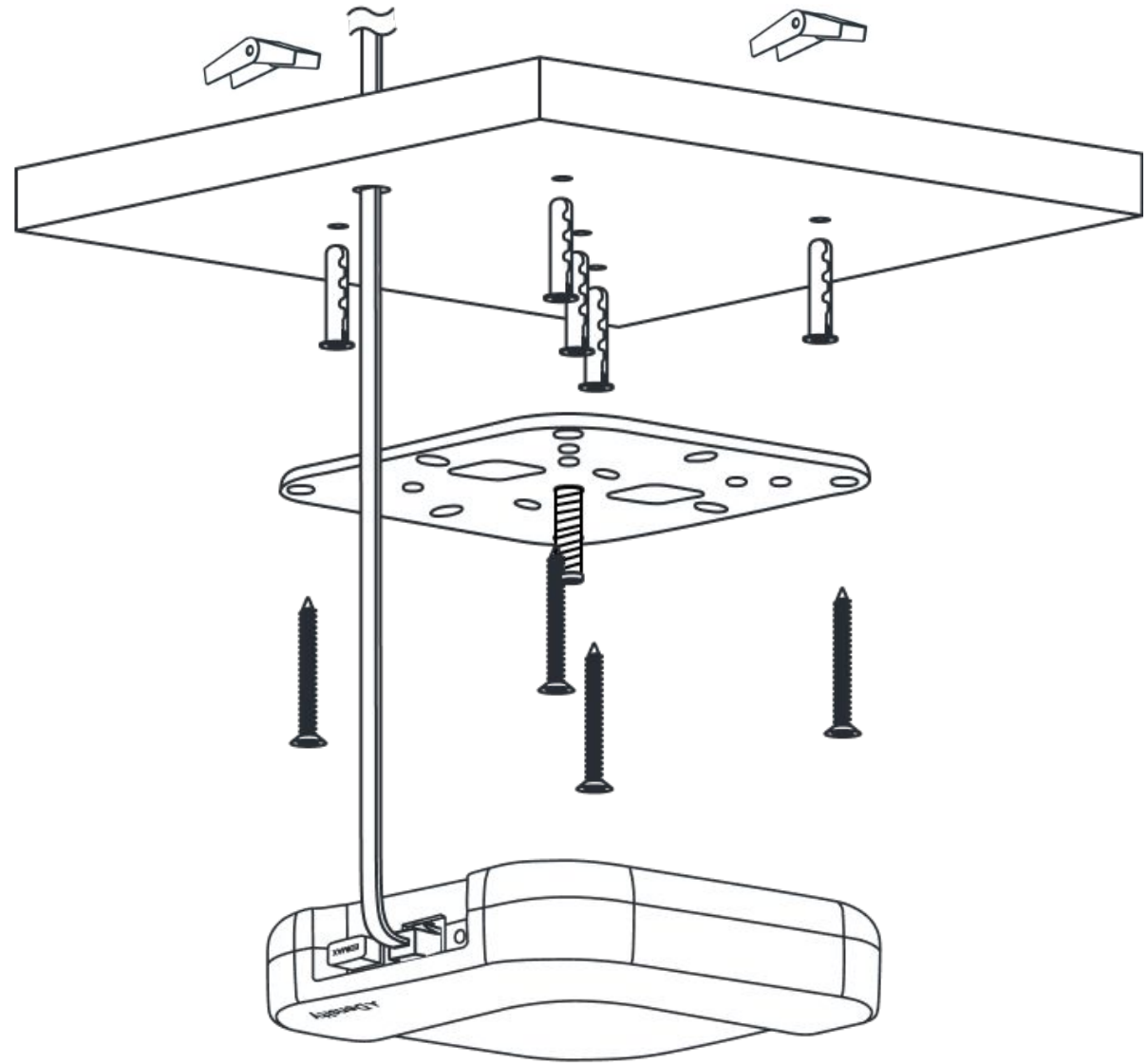

Step 1: Mark placement

Using a pencil or pen, mark the location on the ceiling for anchor screws. We recommend fastening the mount plate with at least two screws.

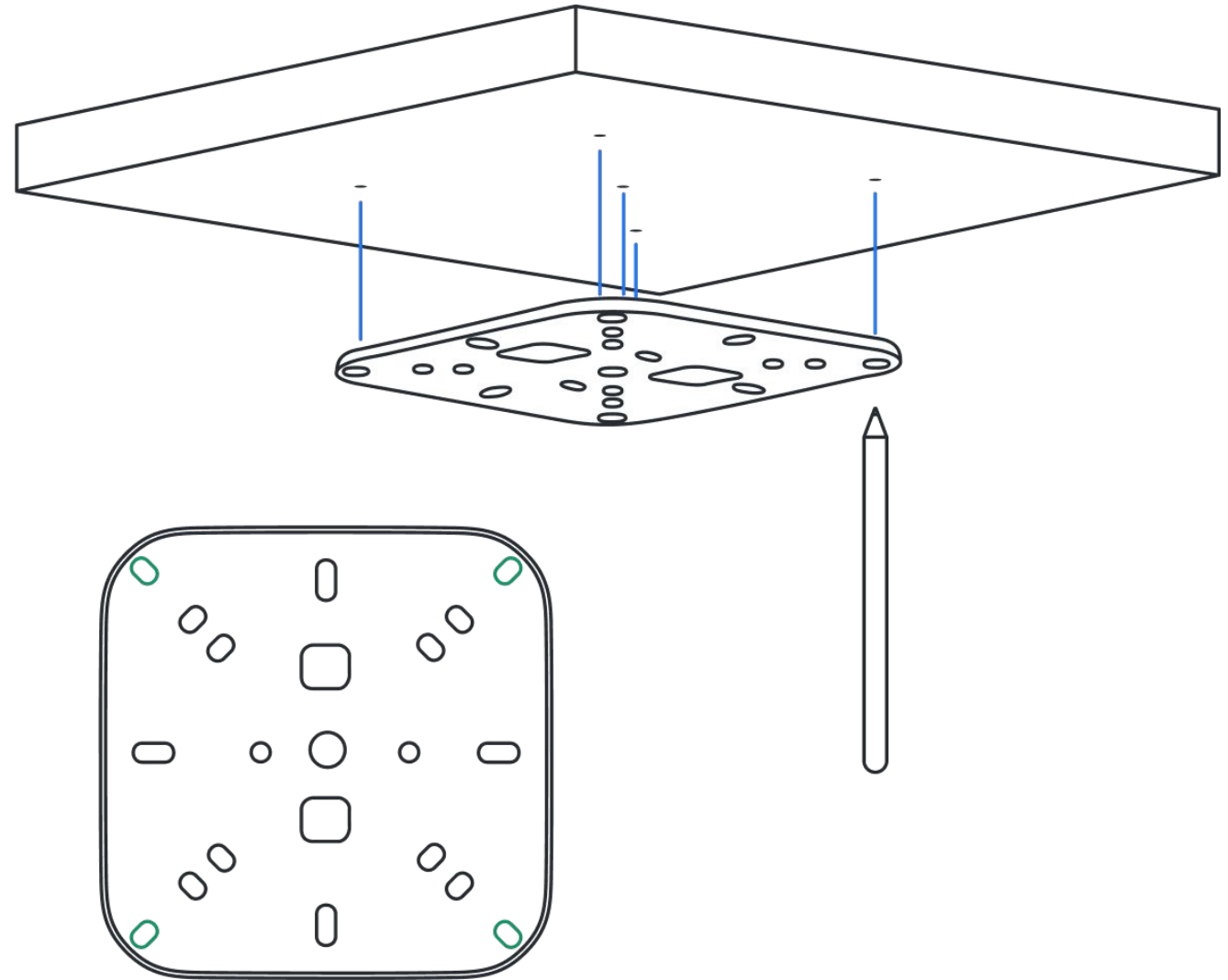

Step 2: Drill holes

Drill a hole through each pencil mark using the recommended sizing for the mounting hardware and anchors (not included).

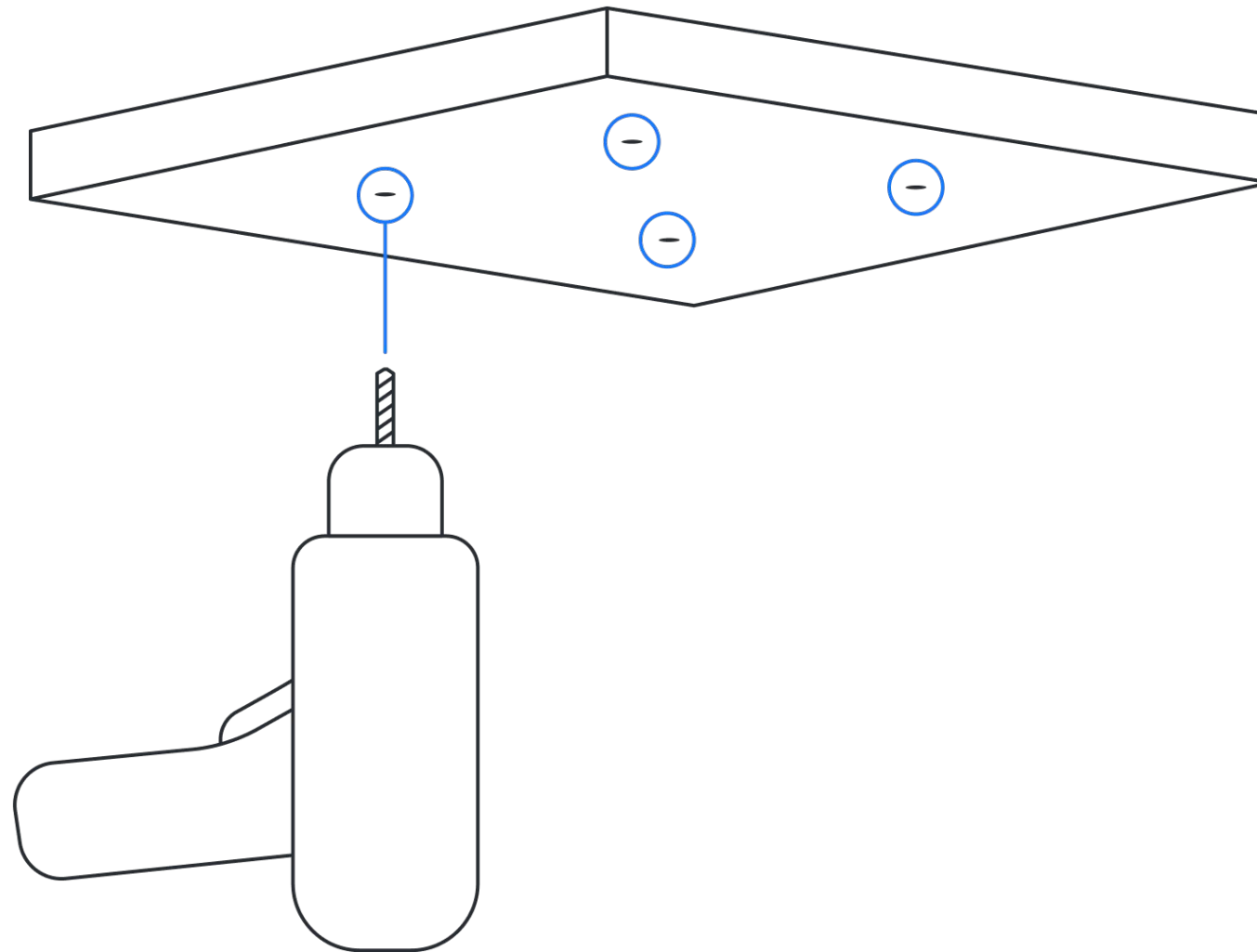

Step 3: Insert anchors

For hollow surfaces only, use a mallet to tap the anchors into each hole. Anchors should be flush with the surface. If utilizing toggle anchors, ensure proper size is used for screws chosen.

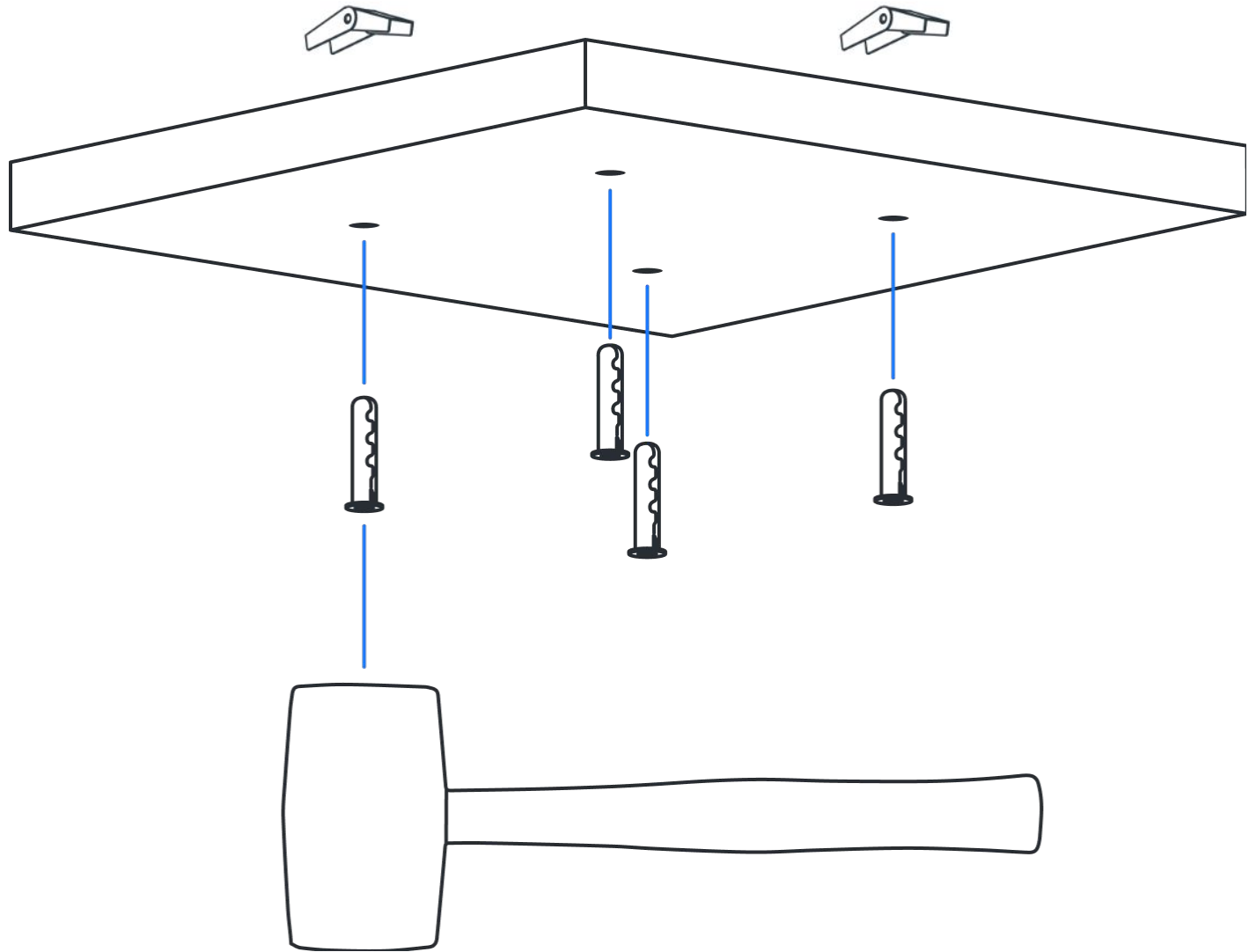

Step 4: Install mount plate

Align the holes in the mount plate with the installed anchors. Use a drill with #2 Phillips Screwdriver bit to drive each screw into the drywall anchors. Screws can also be driven in manually with a standard Phillips head screwdriver.

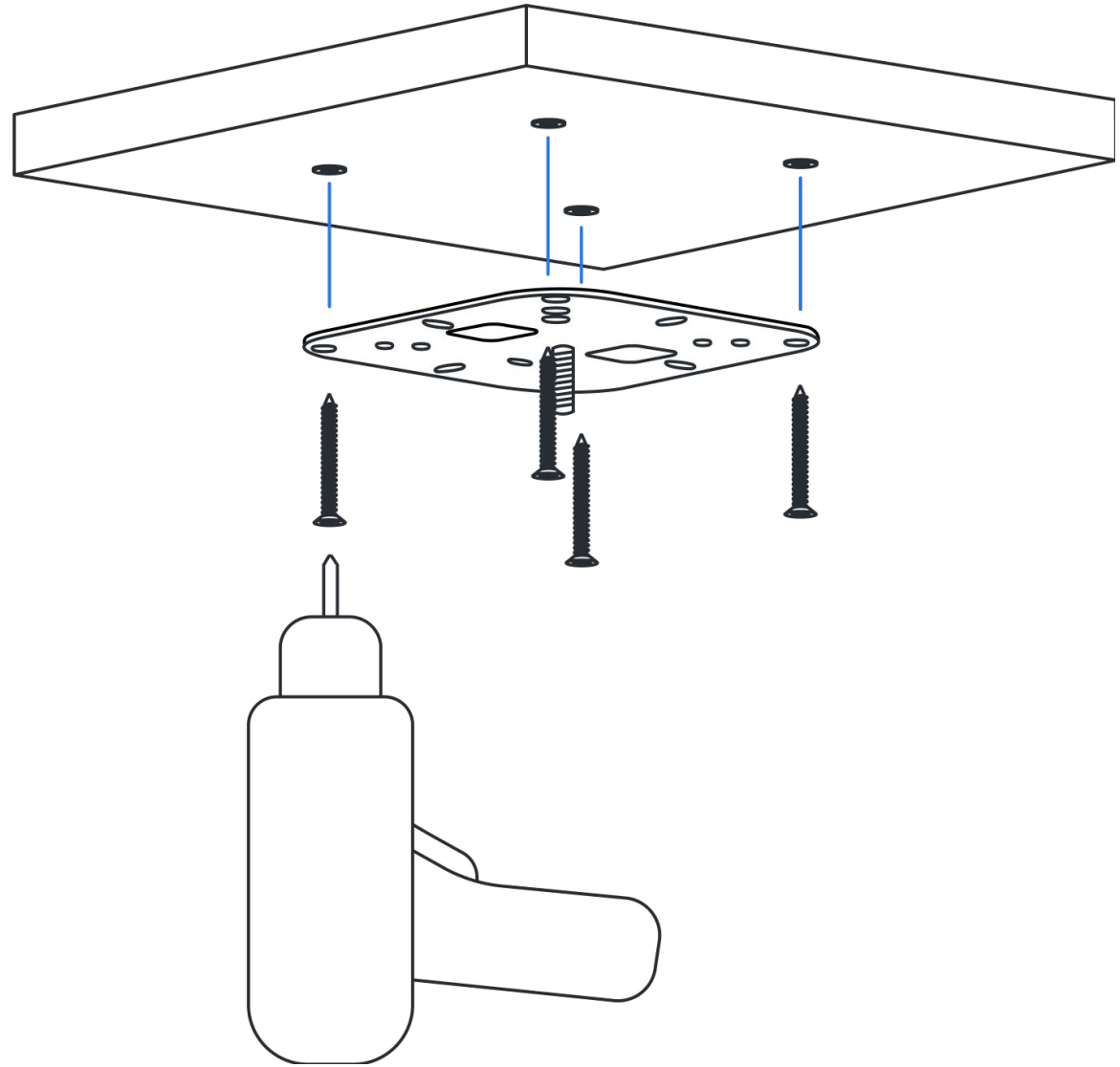

Step 5: Drill cabling hole

Drill a hole using a 3/4in (16mm) drill bit to route the cable through. (Please ensure you leave adequate spacing for proper cable bend radius)

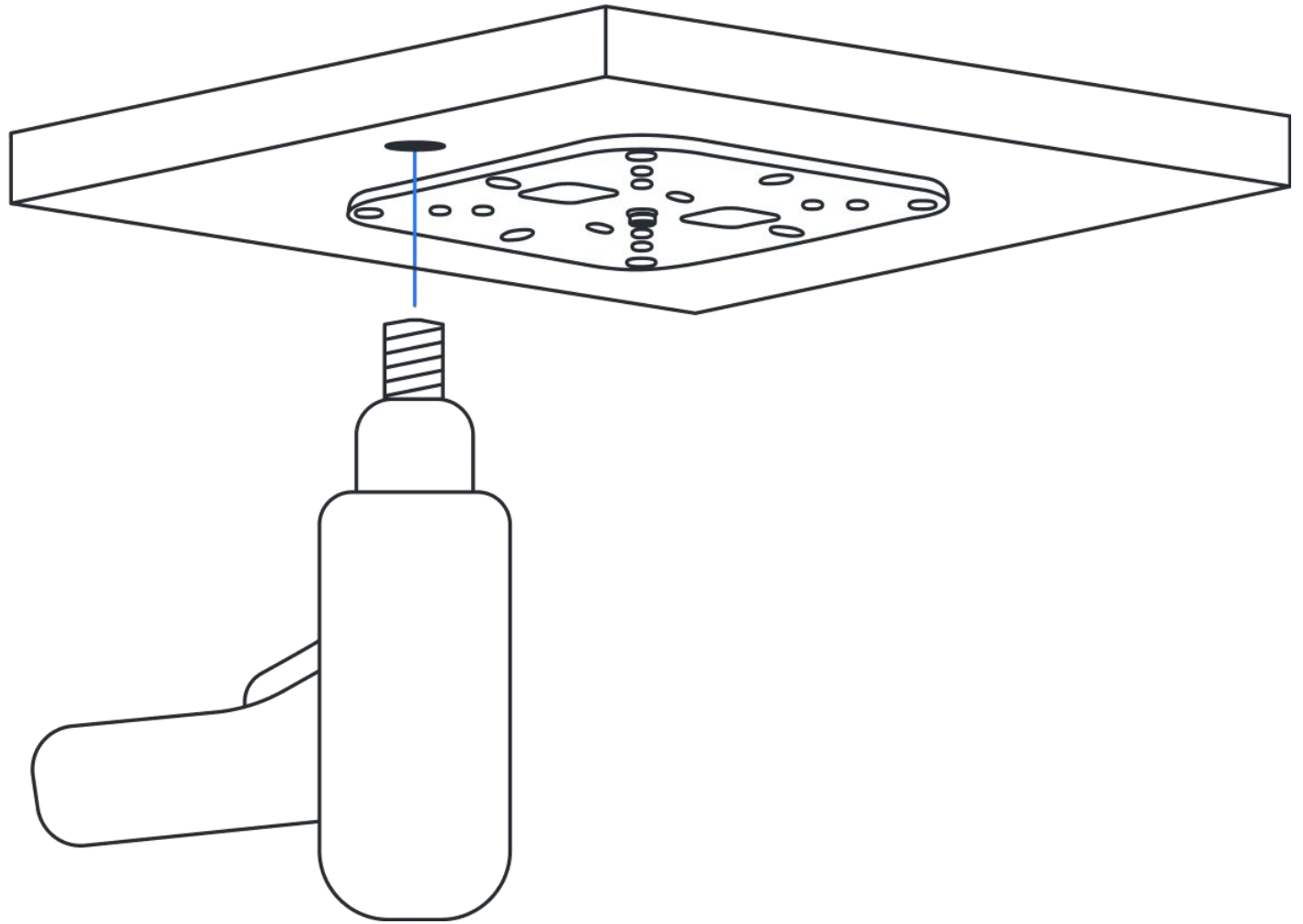

Step 6: Route cable

Route the ethernet cable through the drilled hole.

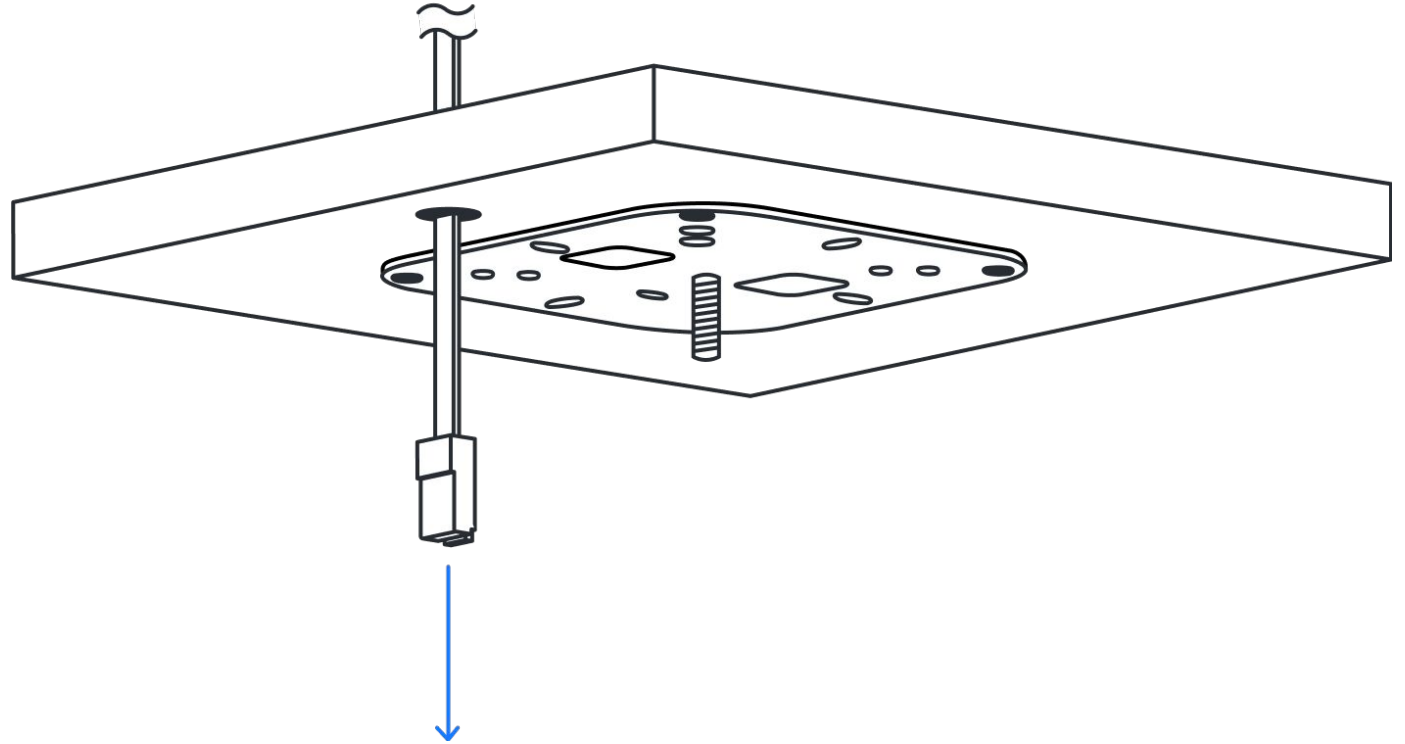

Step 7: Attach Entry LR Sensor

Attach the Entry LR unit by threading onto the bracket. Pull the ethernet cable through approximately 6 inches out from the opening in the ceiling.

Screw the unit on all the way until it stops, then back it off to the prescribed location using the ethernet jack as the location guide.

Warning! Do not over-tighten as this can damage the unit.

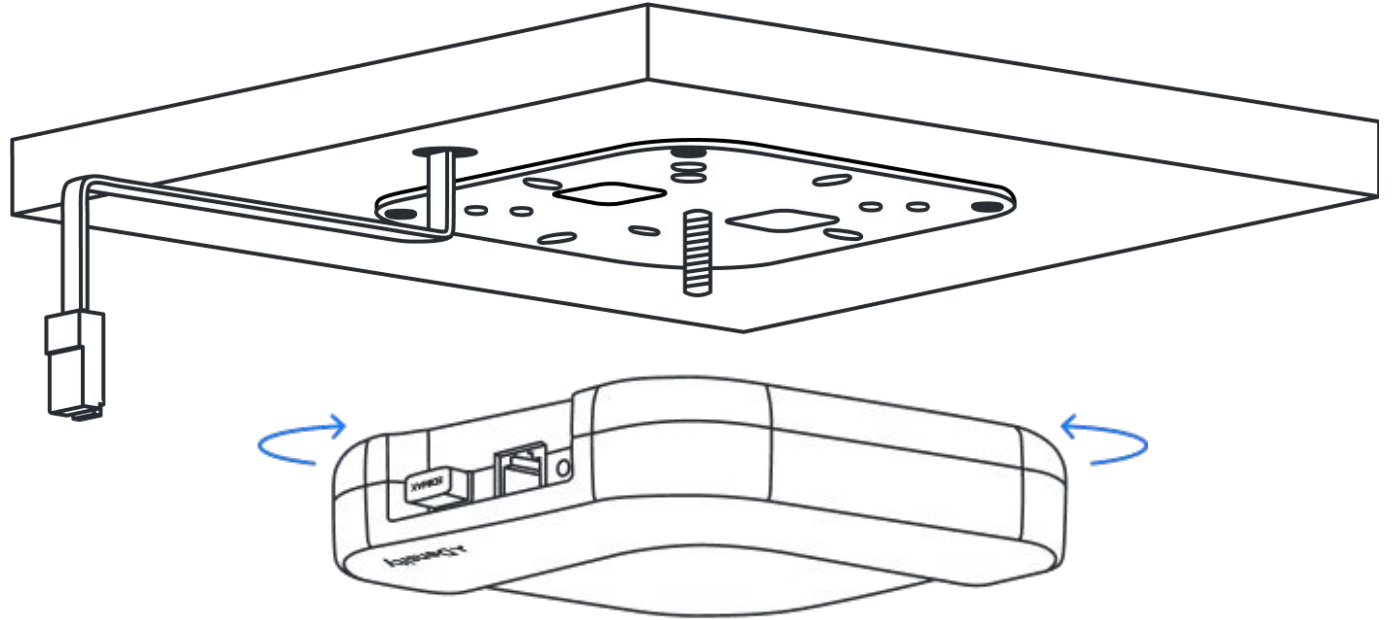
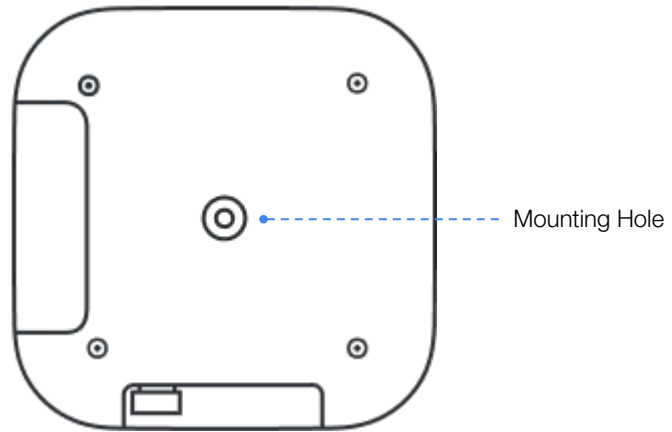

Step 8: Plug in cable

Plug the ethernet cable into the Entry LR Sensor.

Ensure the Entry LR unit is level and parallel to the floor.

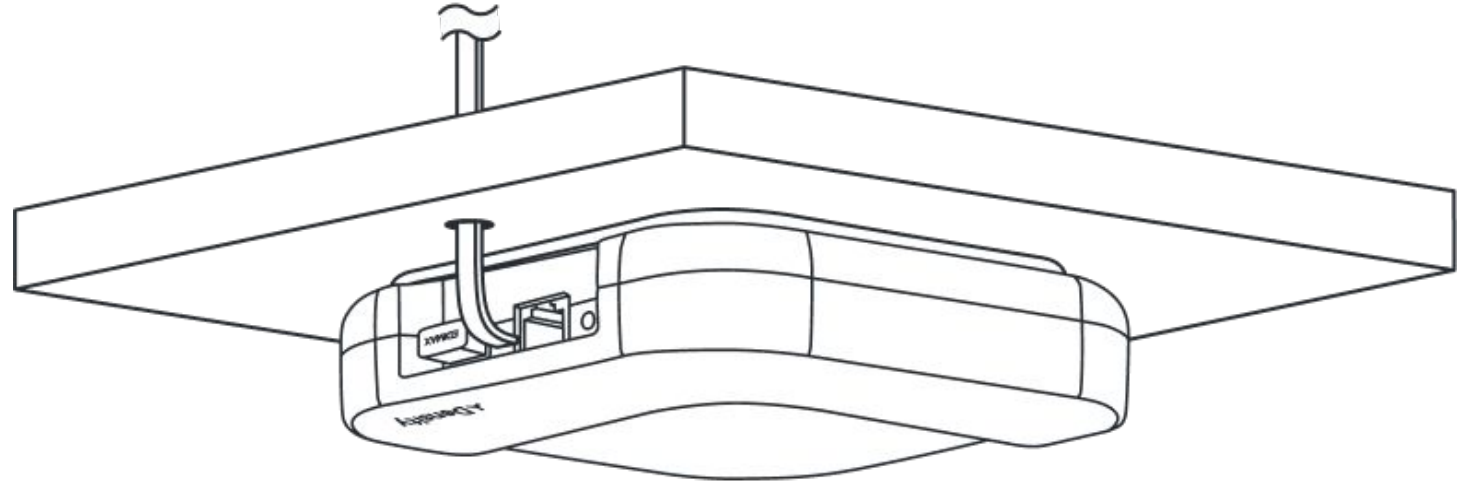

Wall Mount

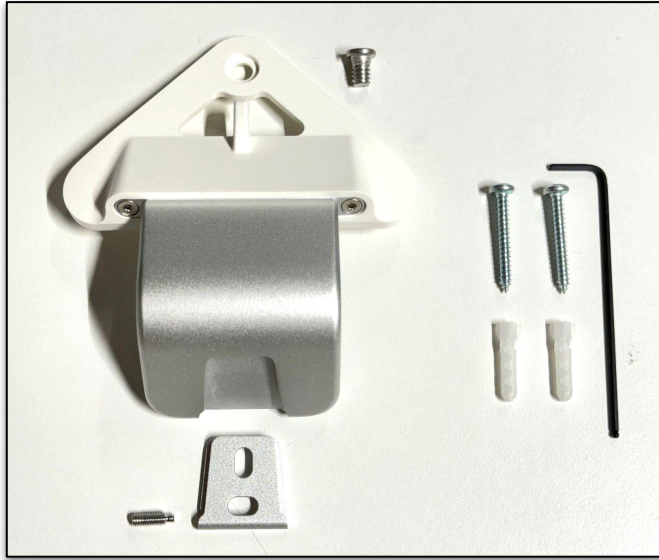

Wall Mount Kit (895-0011; available for order)

- + (1) ELR Wall Mount Assembly
- + (1) 300-0024 Mount Bracket (installed)
- + (1) 350-0019 Mount Arm to Mount Bracket Set Screw (installed)
- + (1) 350-0056 Wall Mount Assembly to Unit Screw
- + (1) 350-0020 2mm Allen Key for 350-0019 & 350-0021

Materials NOT included

- + Drill
- + Mallet or Hammer
- + Level
- + #2 Phillips Screwdriver
- + Measuring tape
- + Pencil
- + 3/16in drill bit
- + Ethernet Cable (Cat 5e or later)
- + (2) 350-0014 #8 x 1.25" Sheet Metal Screws
- + (2) 350-0015 Drywall Anchors

Power & connectivity

All sensors require power over ethernet and internet connectivity.

Mounting with Screws and Anchors

The Wall Mount Kit comes with 2pcs #8 x 1.25" Phillips Rounded Head Screws and 2pcs Multi-Surface Toggler Anchors designed for a wide range of materials (concrete, brick, stone, drywall, etc.). The anchor expands and elongates within a solid substrate to distribute force evenly. For hollow substrates, the anchor jaws pop open to lock into position.

Anchors should be used for all wall materials except for wood. For wood, use the screws and drill directly into the surface.

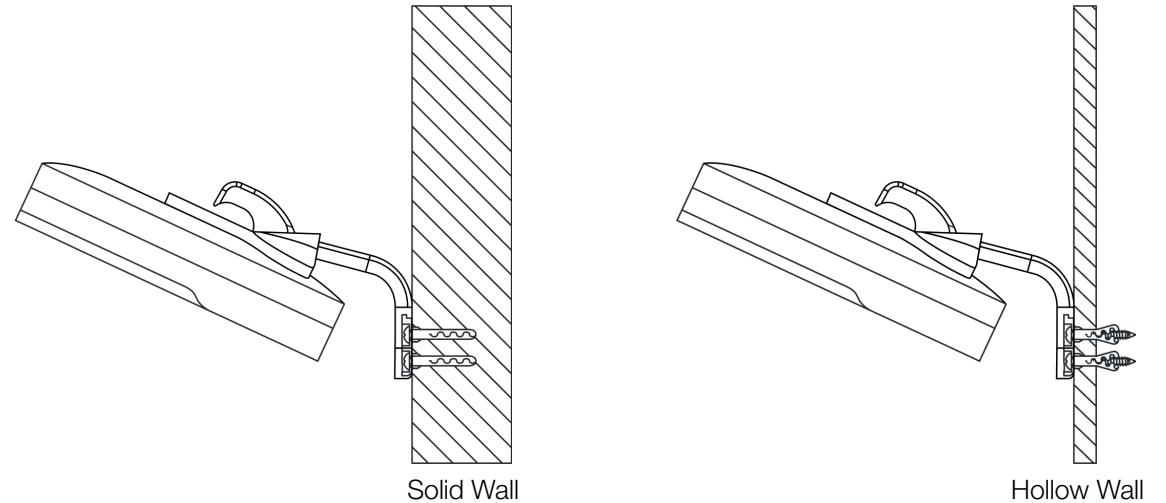
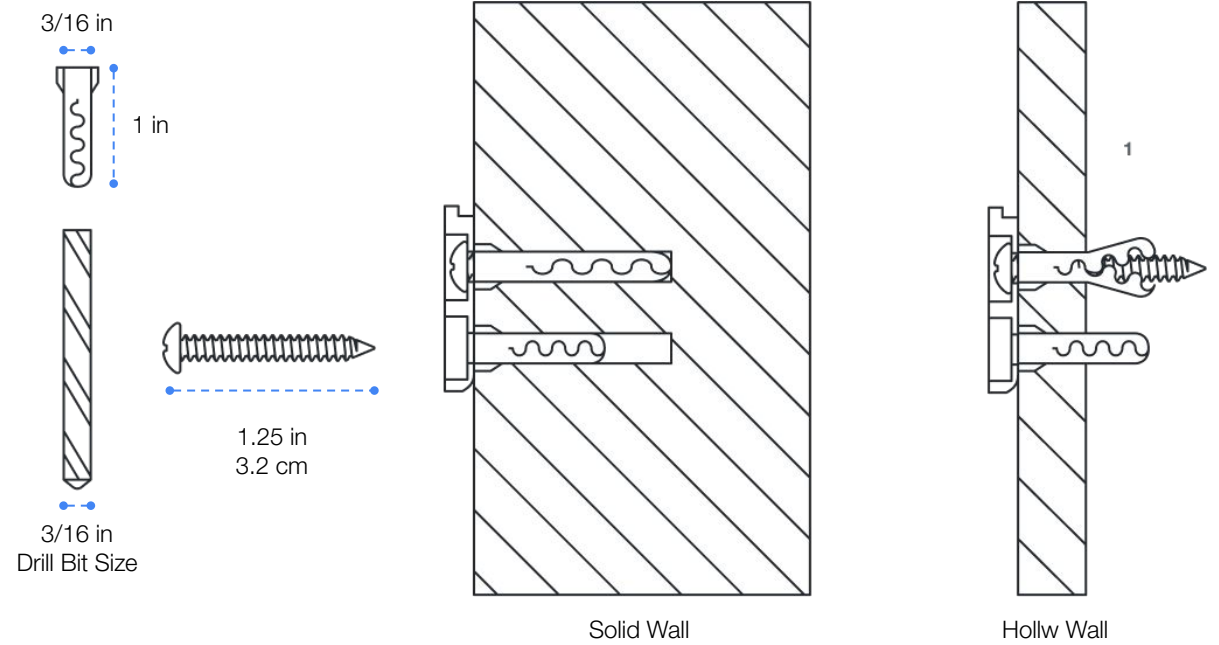

Cable Management - Hidden

For hollow wall installs, the cable can be hidden by drilling a hole into the wall material and threading the ethernet cable through the drilled hole.

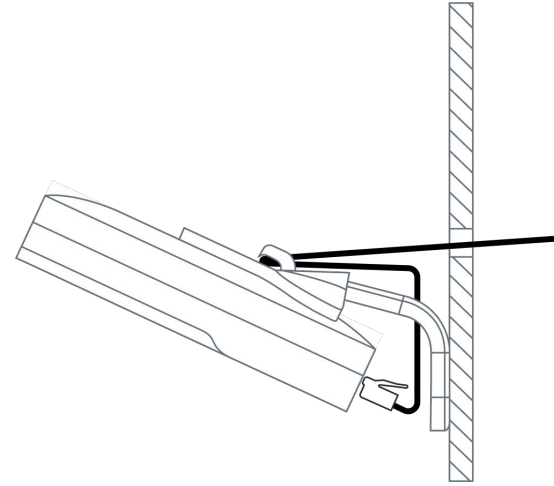

Cable Management - Exposed

For solid and hollow wall installs, the cable can be secured directly to the wall surface using cable clip fasteners or channeling.

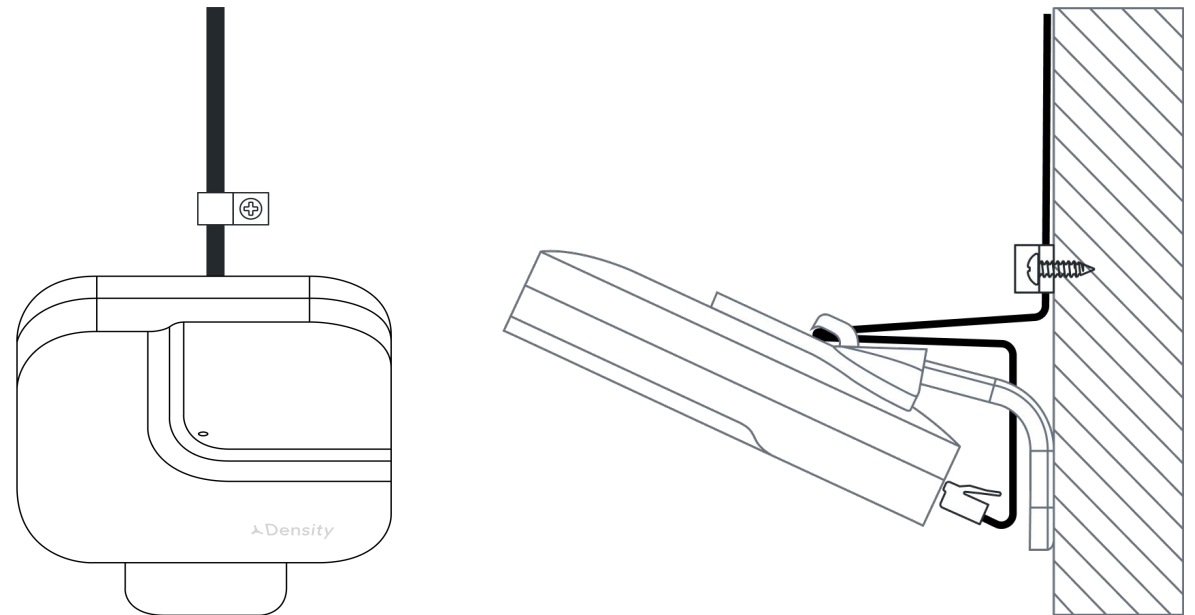

Step 1: Prepare The Sensor

Use a 2mm Hex Key to release the Wall Bracket from the Mount Arm.

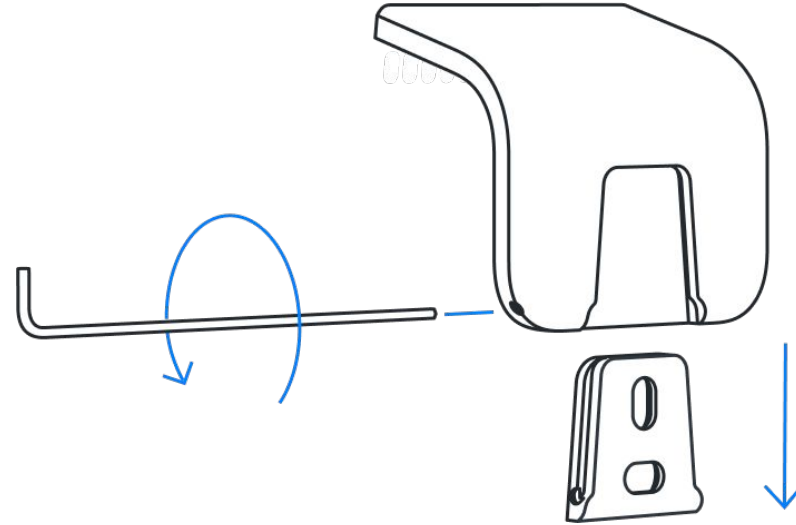

Step 2: Mark Placement

Before installing, refer to and follow the supported mounting height and clearance requirements in section 5.

Center the Wall Bracket horizontally above the doorway. Use the level to ensure the Wall Bracket is parallel to the ground. Use a pencil to mark the center of the two holes in the Wall Bracket.

If any objects obstruct the sensor, you may install the sensor slightly off-center or consider moving the obstruction. Please consult your Density Account Manager before offsetting the sensor.

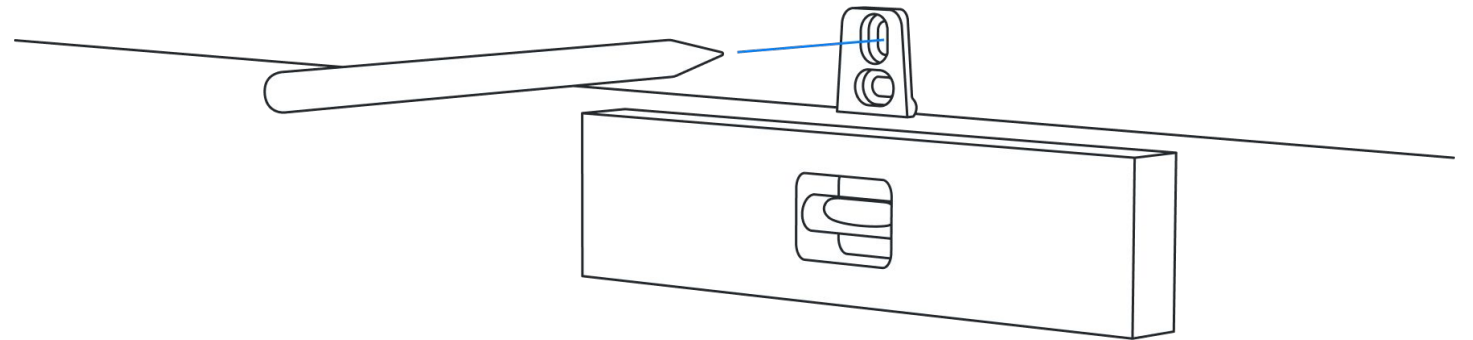

Step 3: Drill Holes

Drill a hole through each pencil mark using a 3/16 in drill bit. For hollow substrates, drill completely through. For solid wall materials, drill holes with a depth of at least 1 1/4 in (3.2 cm).

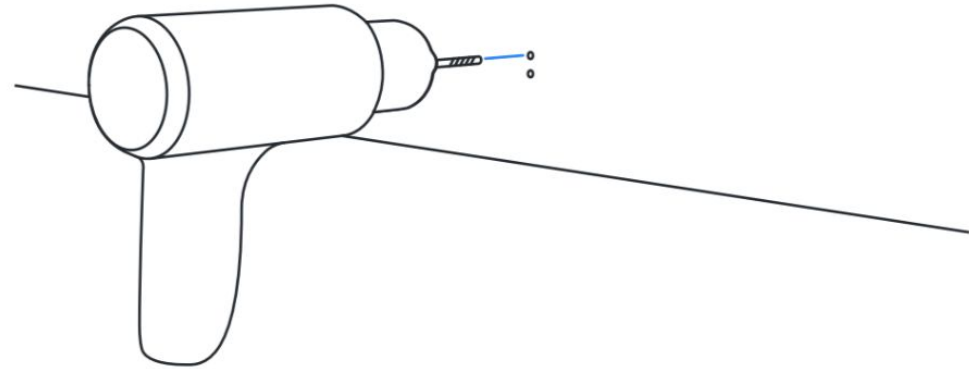

Step 4: Insert Anchors

Use a mallet or hammer to tap the anchors into each hole. Anchors should be flush with the wall.

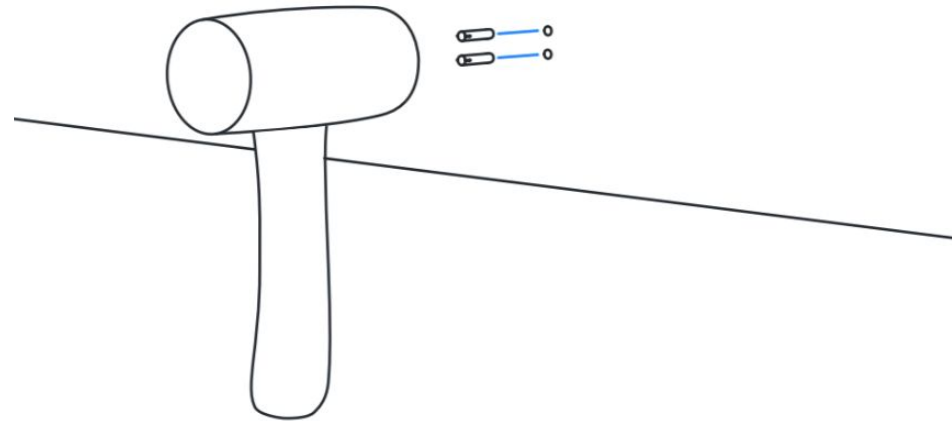

Step 5: Install Wall Bracket

Align the holes in the Wall Bracket with the installed anchors. Use a drill with #2 Phillips Screwdriver Bit or a standard Phillips head screwdriver to drive each screw into the drywall anchors.

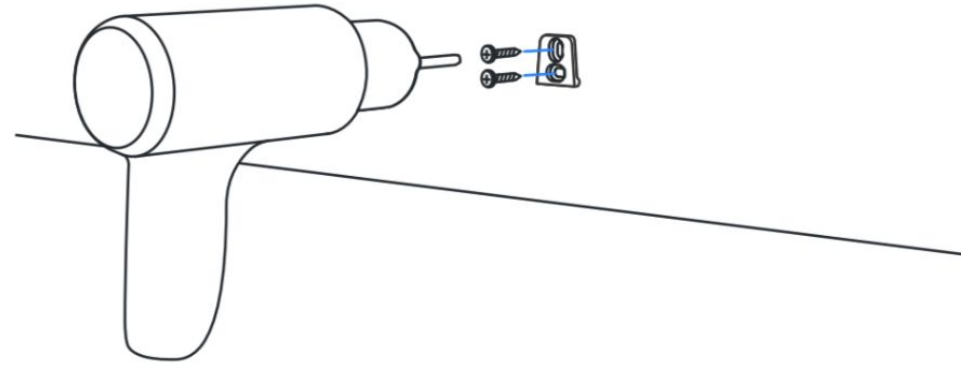

Step 6: Connecting Sensor to Mounting Arm

Position the sensor so that the network cable port is pointing at the wall bracket.

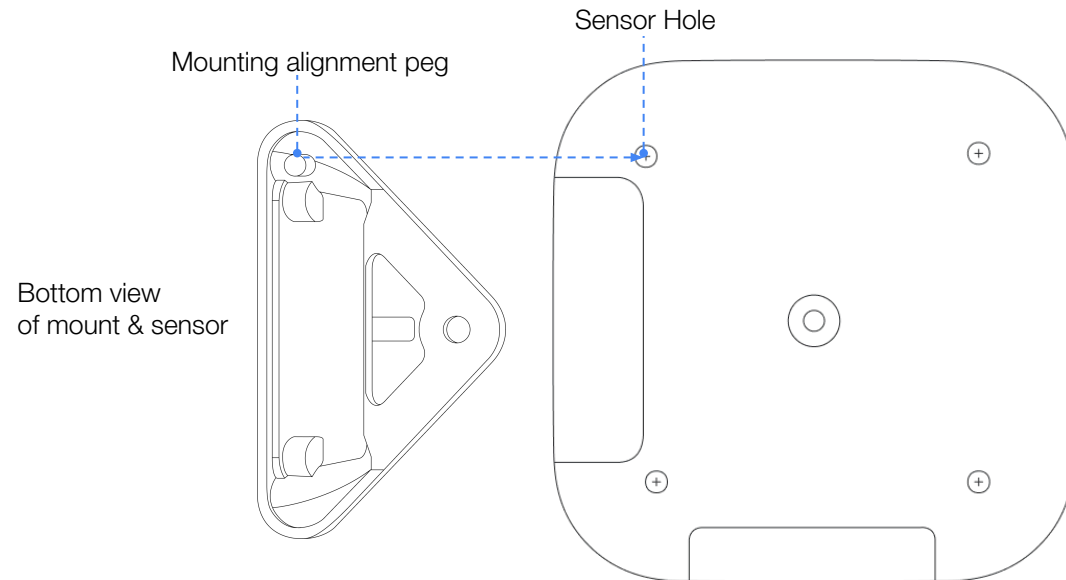

Step 7: Align the mounting alignment peg of the bracket with the hole on the sensor

Make sure to align the mounting alignment peg of the bracket with the hole on the back of the sensor and confirm that the screw position is aligned.

Side view
of mount & sensor

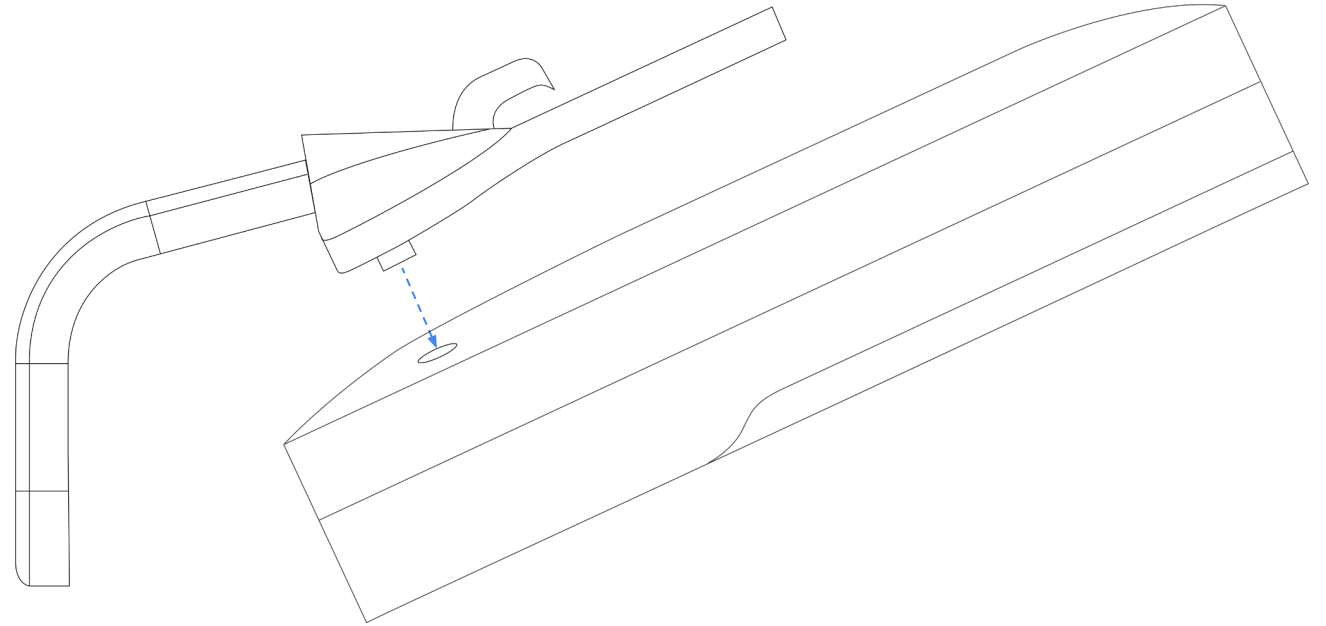

Step 8: Secure sensor to arm bracket

Use a Phillips head screwdriver and screw the sensor itself into the arm bracket.

Confirm that the network cable port is facing the sensor and that the connection is secured.

Warning! Do not over-tighten as this can damage the unit.

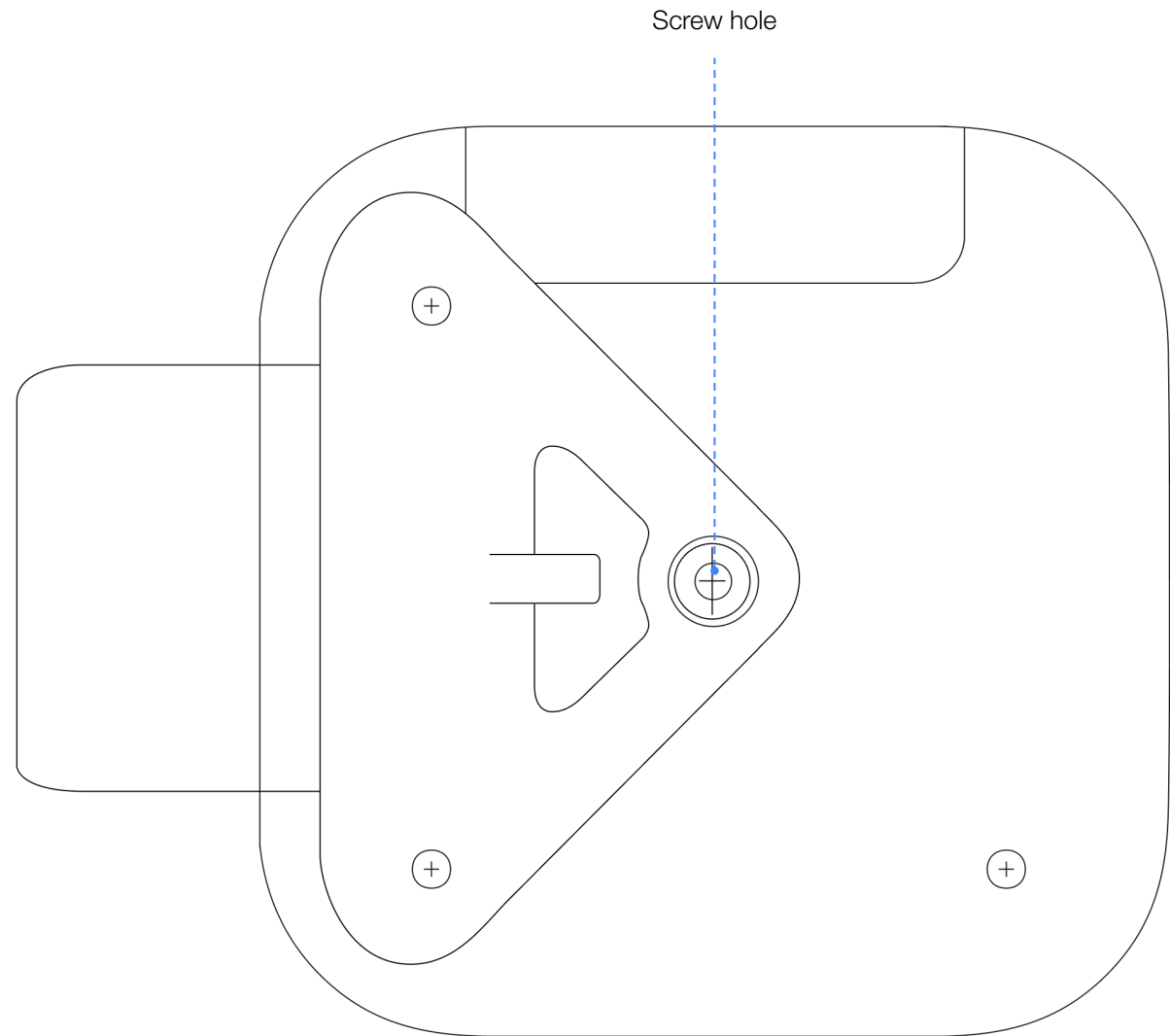

Step 9: Wall Mount

Slide the sensor downward onto the installed Wall Bracket.

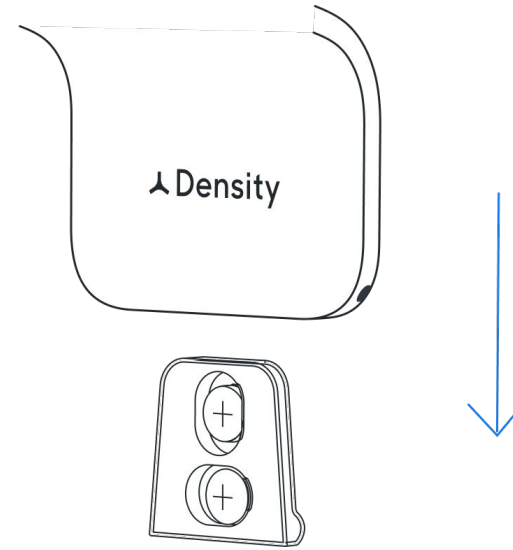

Step 10: Lock Sensor

Lock the sensor to the Wall Bracket with a Hex Key by twisting the set screw all the way in.

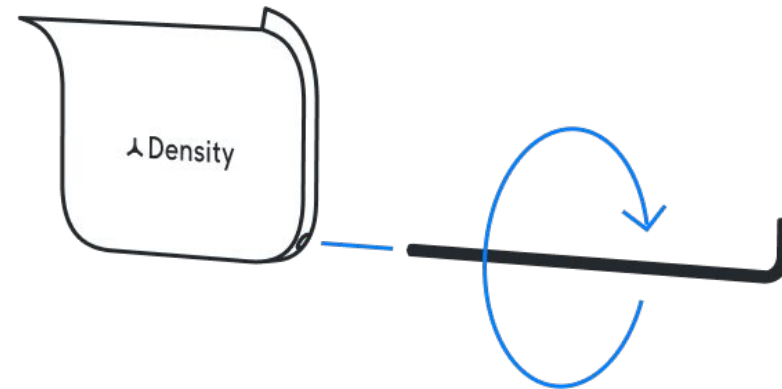

Step 11: Power Up The Sensor

Plug in the ethernet cable. The sensor will automatically power up, and the LED indicator on the front of the sensor will turn white or blue.

See the networking section for troubleshooting information if you see any other colors on the LED indicator.

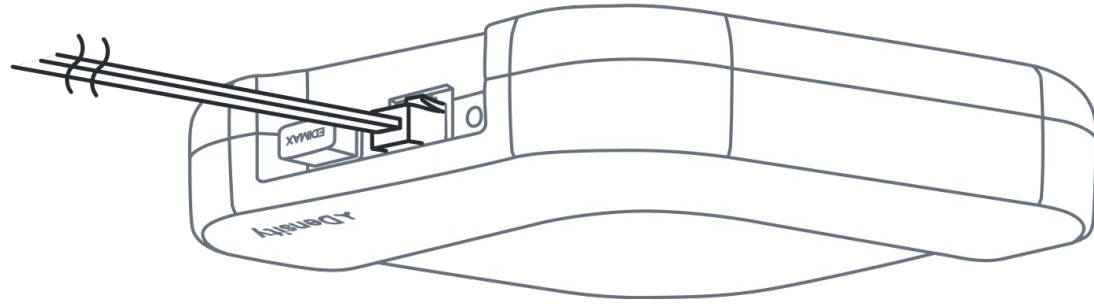

Alternate Mounting Options

Note: Please contact your Density Project Manager or support@density.io to order mounting kits for these mounting options

09

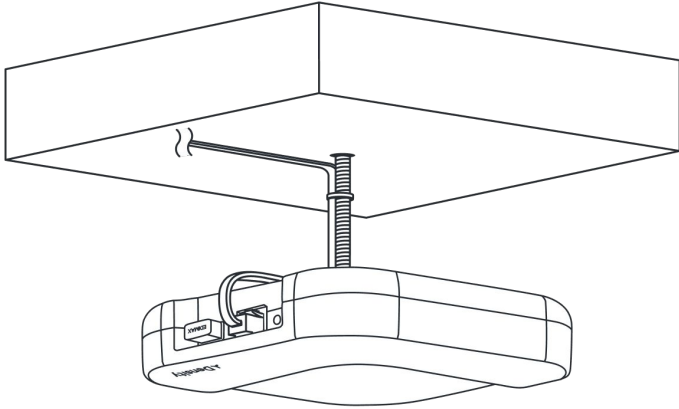

Suspended Ceiling Mounting (Available to Order)

The Threaded Rod Mount is used for mounting the sensor to solid ceiling types (wood, concrete, steel and hollow).

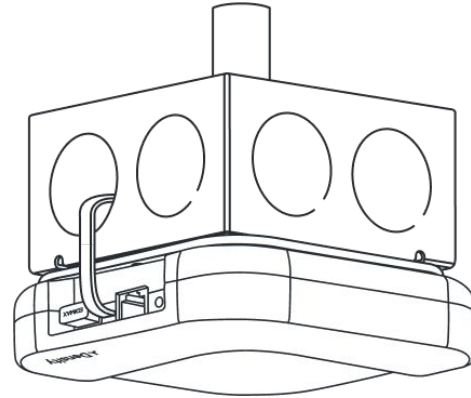

Junction Box Mounting

The Junction Box Mounting is used for mounting the sensor to square, round, or octagonal junction boxes.

Suspended Ceiling Mounting

For solid ceiling types
(wood, concrete, steel, and hollow)

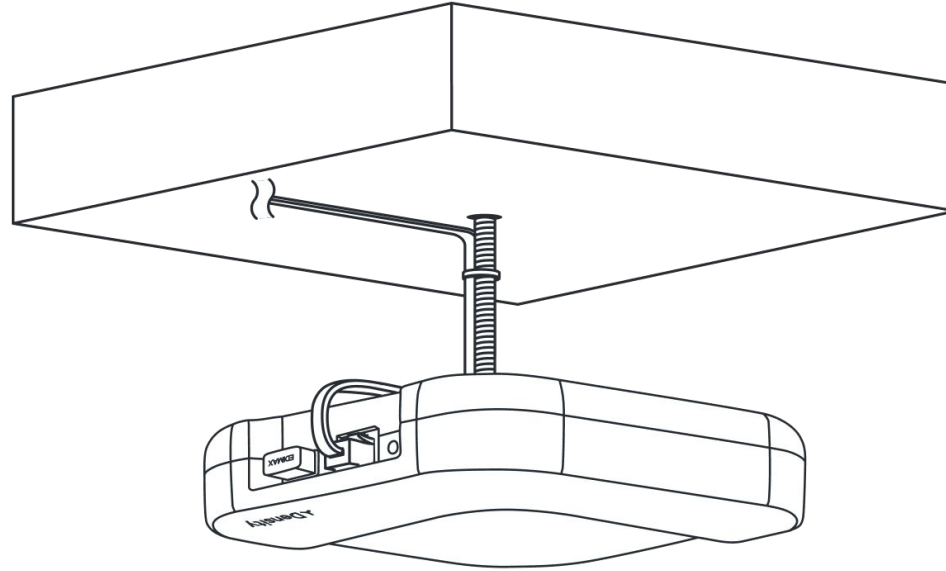

Suspended Ceiling mount (available for order)

- + Hex Key
- + Threaded Rod Anchor - Wood
- + Threaded Rod Anchor - Steel
- + Expansions Anchor - Concrete
- + Installation Tool - Concrete
- + 1/4in-20 Toggle Anchor - Hollow
- + Steel Washer
- + Hex Nut

Materials NOT included

- + Drill
- + Hammer
- + 5/8in Drill Bit
- + 5/8in drive socket (wood only)
- + 1/2in drive socket (steel only)
- + ANSI 3/8in masonry bit (concrete only)
- + 1/4in-20 threaded rod
- + Cable management clips
- + PVC pipe (optional for cable management)
- + Ethernet cable (Cat 5e or later)

Power & connectivity

All sensors require power over ethernet and internet connectivity.

Threaded rod anchor assembly

The Entry LR Sensor can be suspended from a 1/4in 20 threaded rod and mounted to solid wood, concrete or steel ceiling types using the threaded rod anchors (not included).

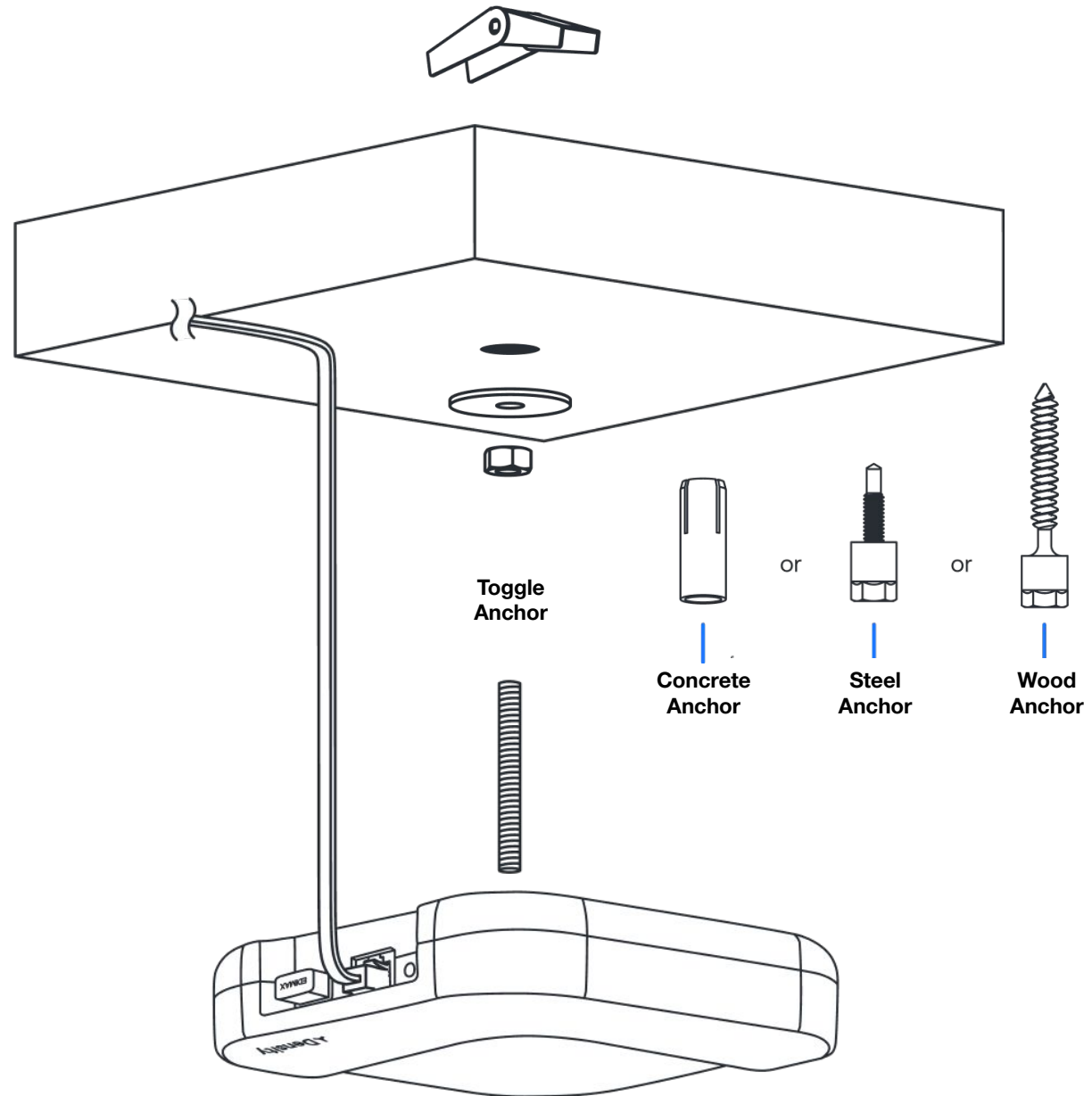

Suspended Ceiling anchors

Install directly into a mounting surface to suspend a threaded rod. Three different mounting anchors are specifically designed for wood, steel, and concrete surfaces. The wood and steel anchors require a drill along with the appropriate sized drive socket (not included) for installation. The concrete anchor requires a hole drilled by an ANSI 3/8in masonry bit, as well as a hammer (not included) and an installation tool (not included).

Wood Anchor

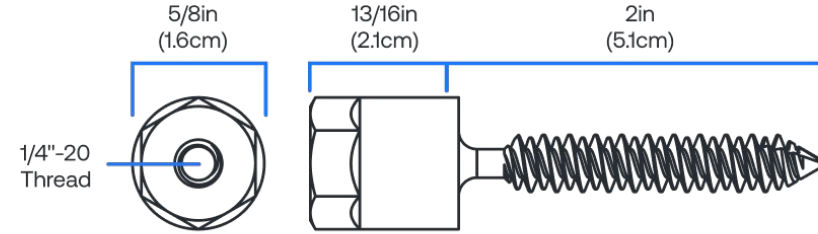

Steel Anchor

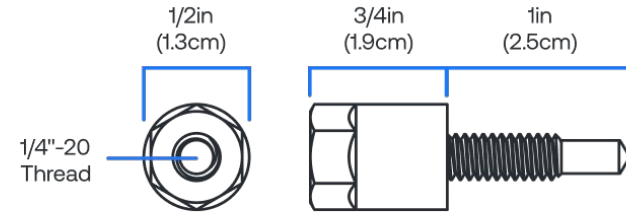

Concrete Anchor

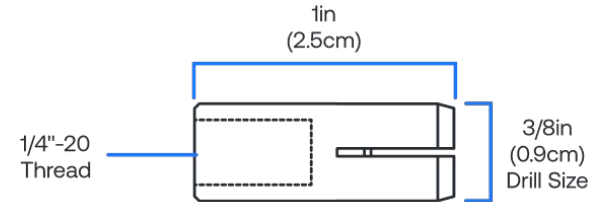

Toggle Anchor

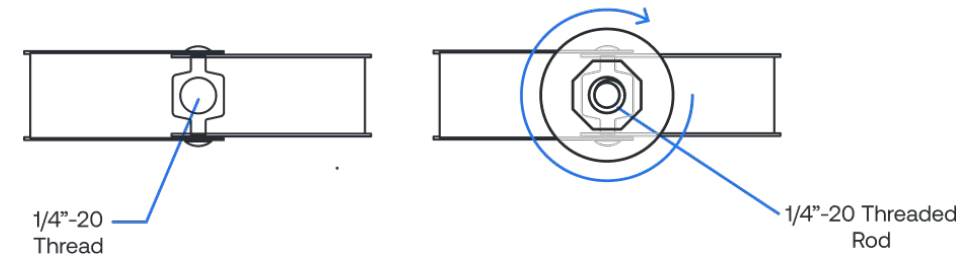

Step 1: Install threaded rod anchor

Wood and Steel installation:

Use a drill and a drive socket (5/8in for wood, 1/2in for steel) to drive the anchor into the ceiling until the bottom side of the anchor head is flush with the ceiling.

Concrete installation:

Anchors for concrete require a hole drilled by an ANSI 3/8in masonry drill bit. To install, place the anchor into the drilled hole, insert the required installation tool into the anchor, and drive with a hammer until the thicker portion of the tool makes contact with the anchor. When installed, anchors sit flush with the surface.

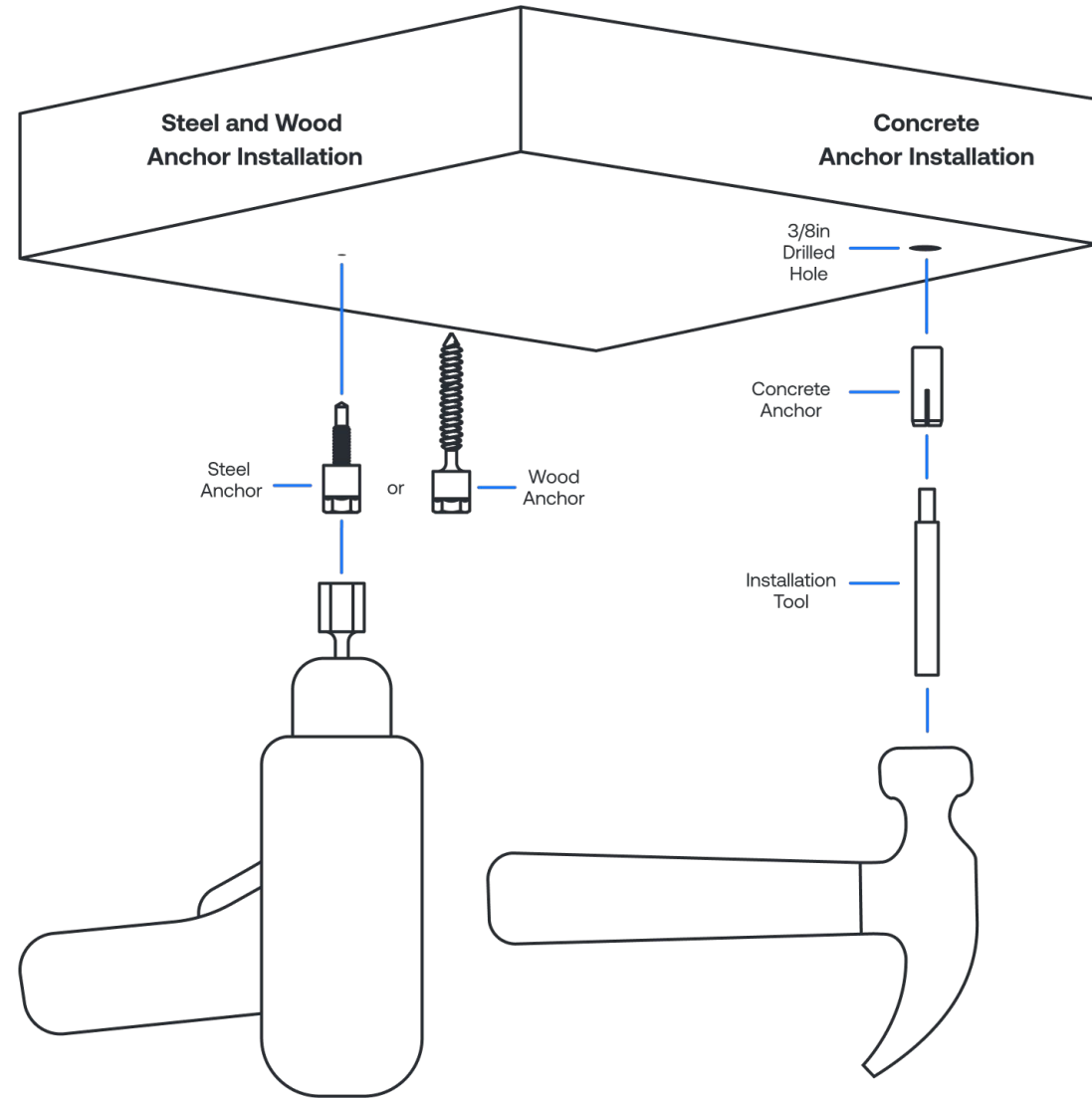
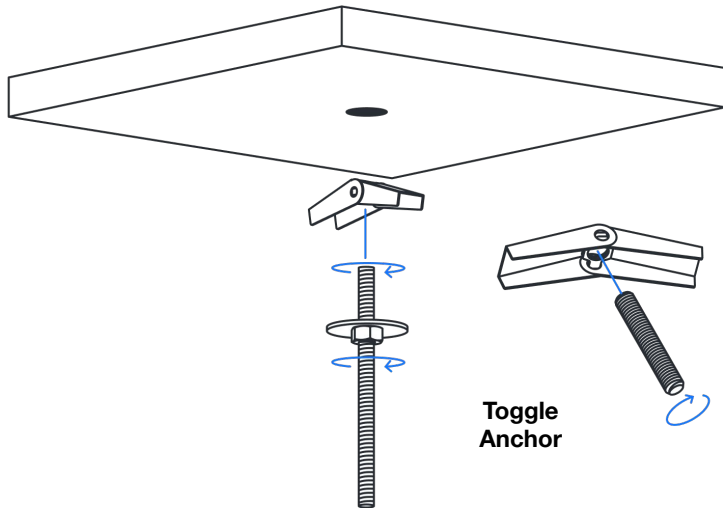

Step 2: Attach Entry LR Sensor

Attach the Entry LR Sensor to the threaded rod by inserting the threaded rod into the 1/4in-20 threads on the back of the Open Area sensor and twisting the sensor onto the rod until tight.

Screw the unit on all the way until it stops, then back it off to the prescribed location using the ethernet jack as the location guide.

Warning! Do not over-tighten as this can damage the unit.

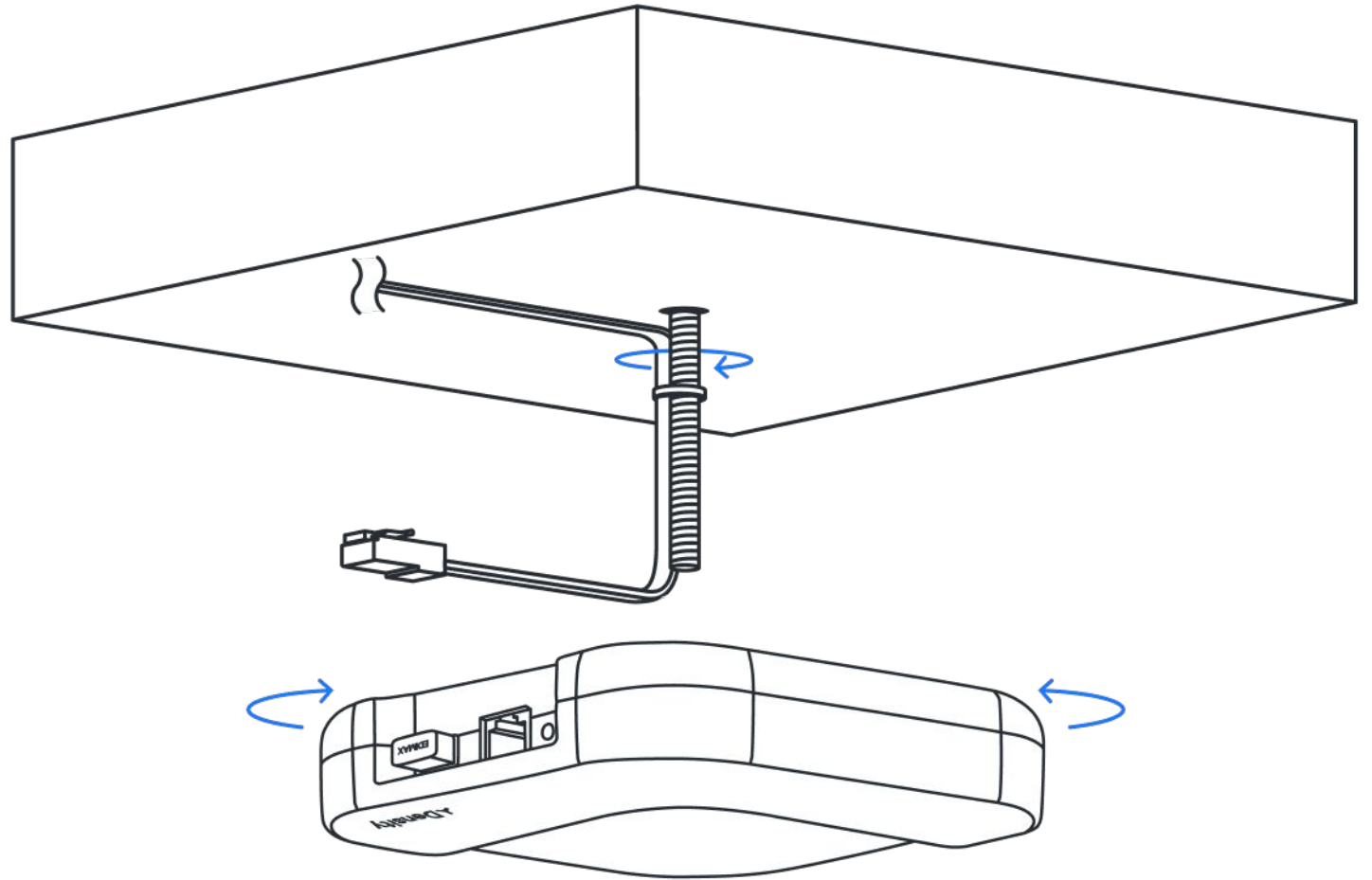
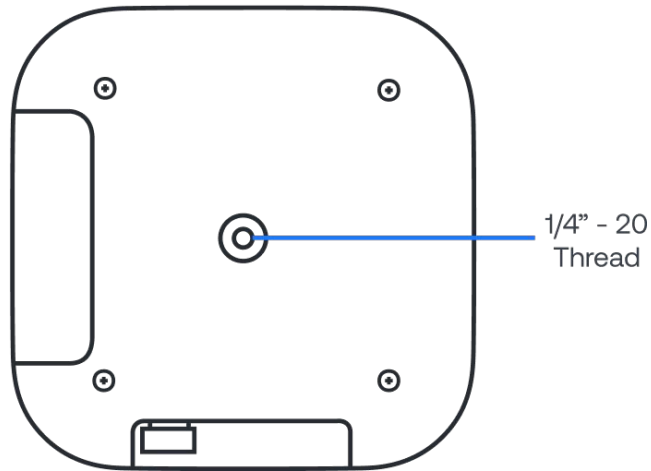

Step 3: Plug in cable

Plug the ethernet cable into the Entry LR Sensor.
Ensure the Open Area unit is level and parallel to
the floor.

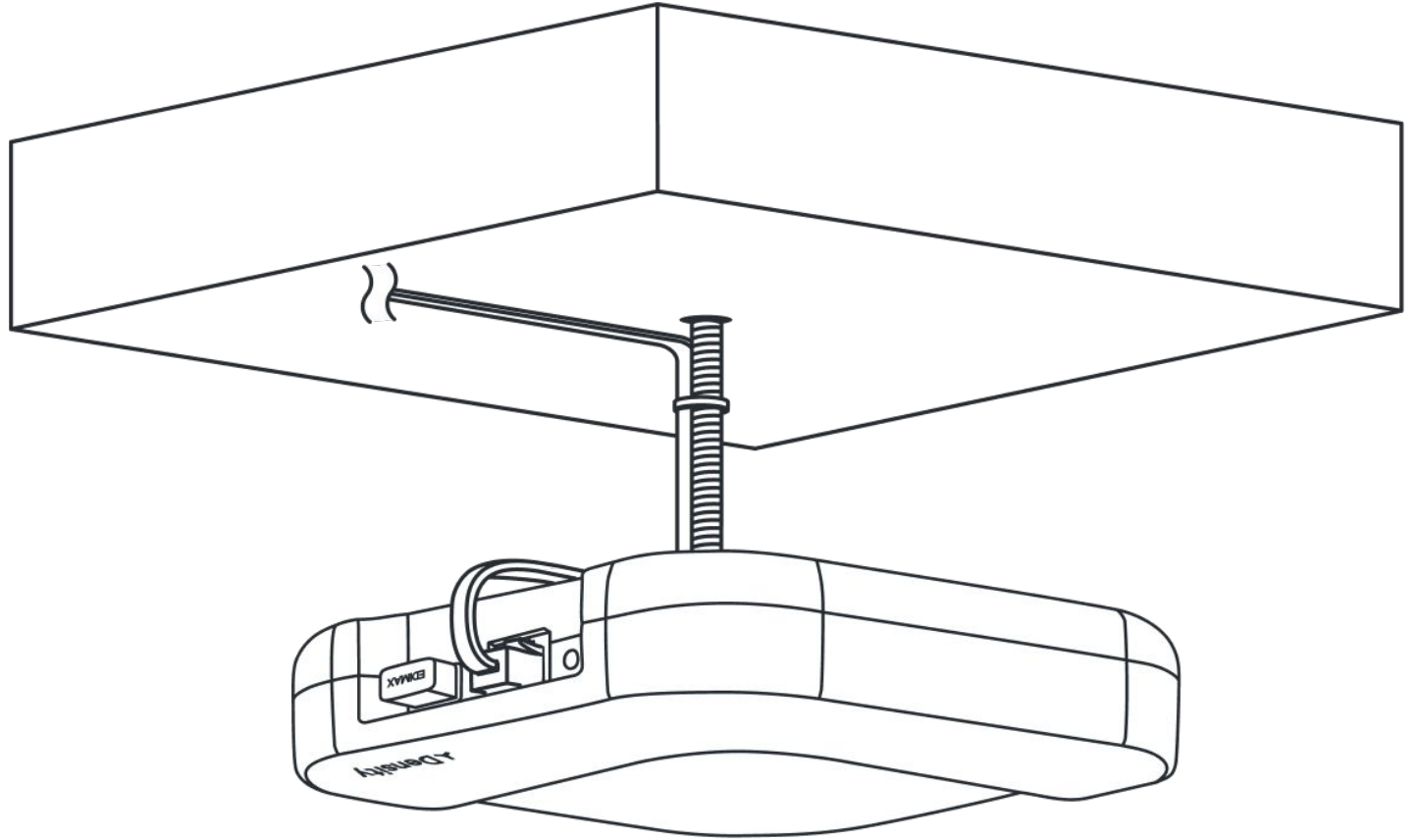

Step 4 (optional): Cable management

A 1/2in PVC pipe can be used to run the cable and rod through. Before assembly, cut the PVC pipe to the proper length and drill or cut a notch or hole at the top of the pipe to allow for cable relief. For optimal cable aesthetics, we recommend using a flat white Cat 5e or greater ethernet cable as shown. Make sure to use a pipe size with a minimum inner diameter of 0.62in (1.6cm). The cable can be attached to the ceiling using a variety of screw or nail in cable management clips.

Be sure to follow recommended minimum bend radius guidelines for any type of cable used.

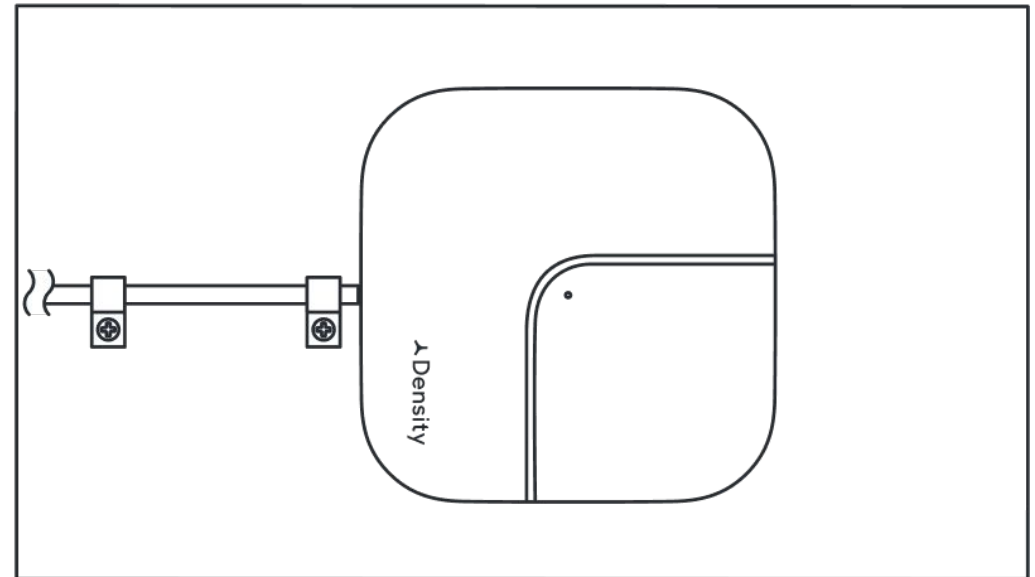
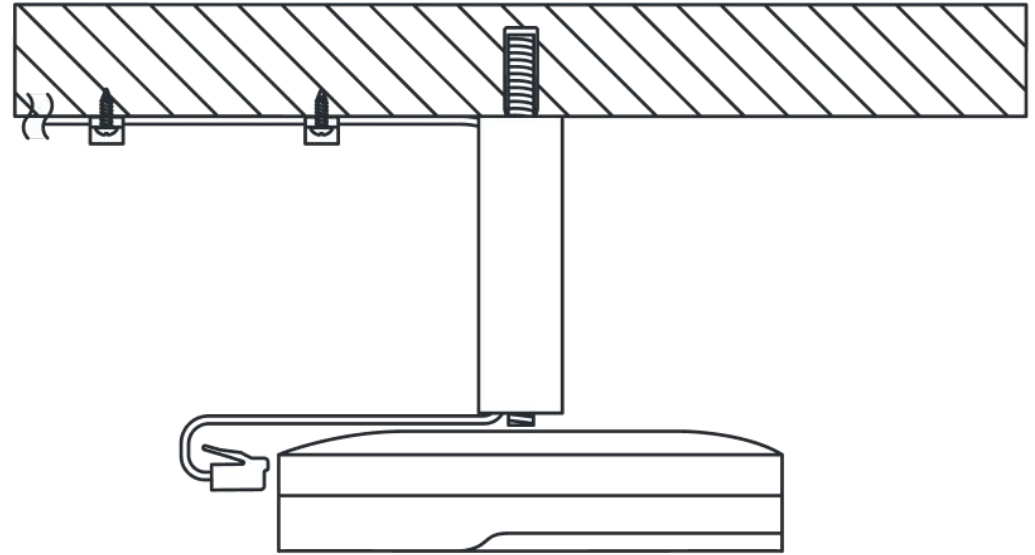
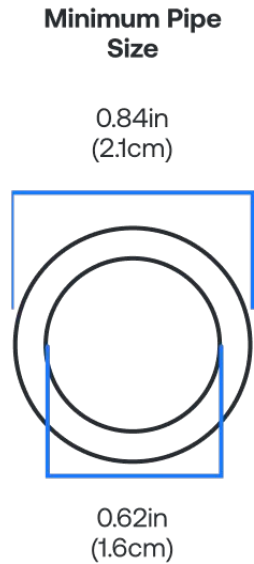

Installation complete

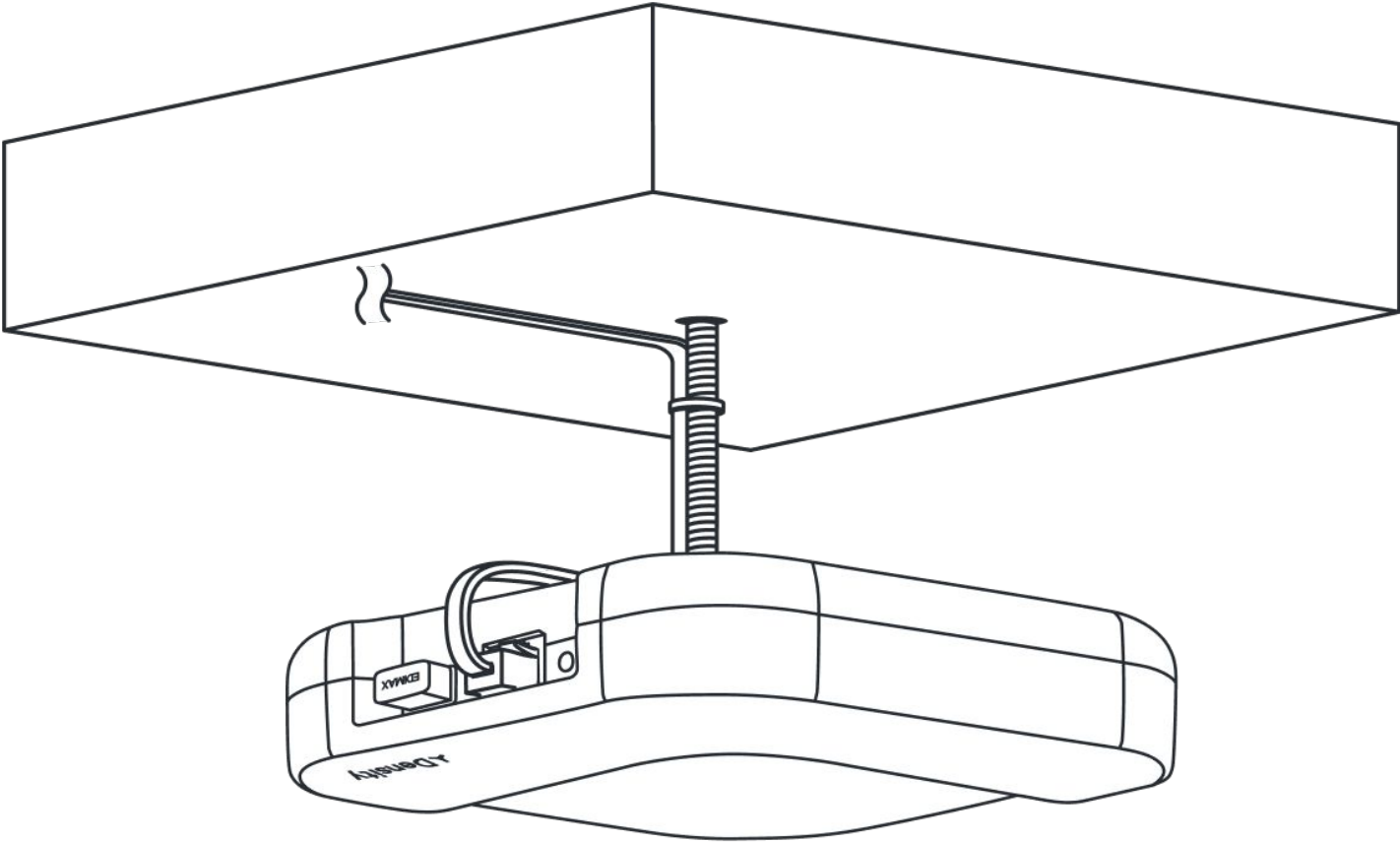

Junction Box Mounting

For mounting to square, round, or octagonal junction boxes

Please ensure that the junction box is not sagging, loose, or crooked.

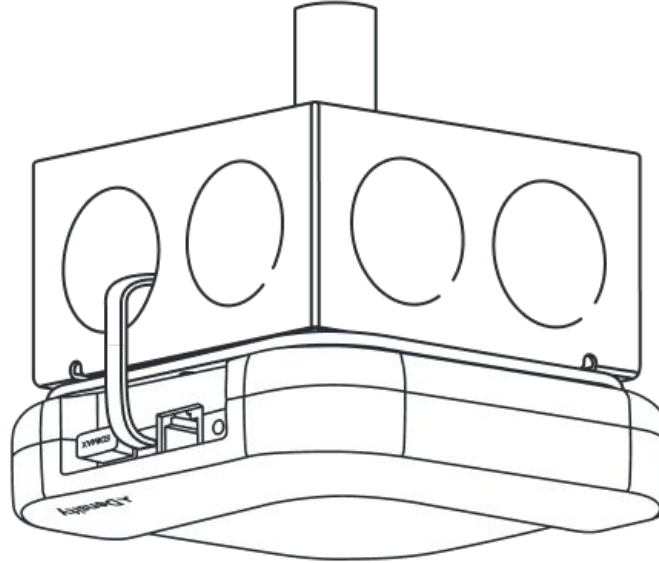

Junction box mounting

- + Mount plate

Materials NOT included

- + Drill or screwdriver
- + Junction box
- + Ethernet cable (Cat 5e or later)
- + Screws

Power & connectivity

All sensors require power over ethernet and internet connectivity.

Junction box mounting

With the junction box hung and positioned, affix the mount plate to the junction box using the appropriate hole pattern and screws.

Mounting Plate

- A. Ceiling or Drop Ceiling Tile
- B. 4" Square Junction Box (US)
- C. 4" Round Junction Box (US)
- D. 3.5" Round Junction Box (US)
- E. Single-Gang Outlet Box (US)
- F. Pass Through
- G. Auxiliary Hole
- H. 1/4"-20 Threaded Stud

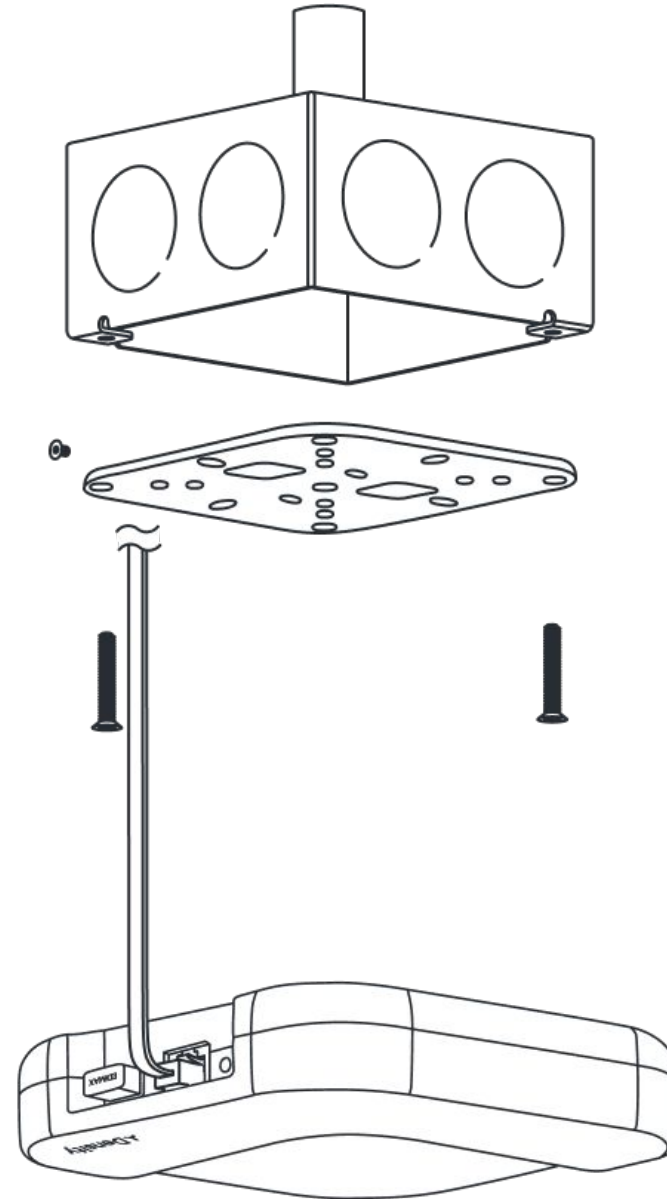
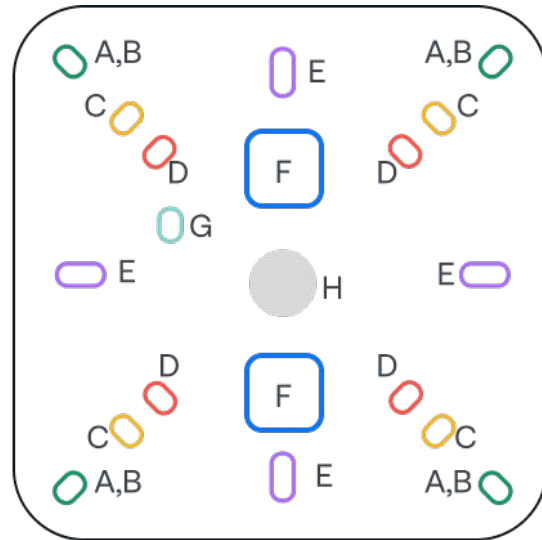

Step 1: Attach mount plate

Attach the mount plate to the junction box using the necessary screws. Make sure you have the proper screw for the desired junction box.

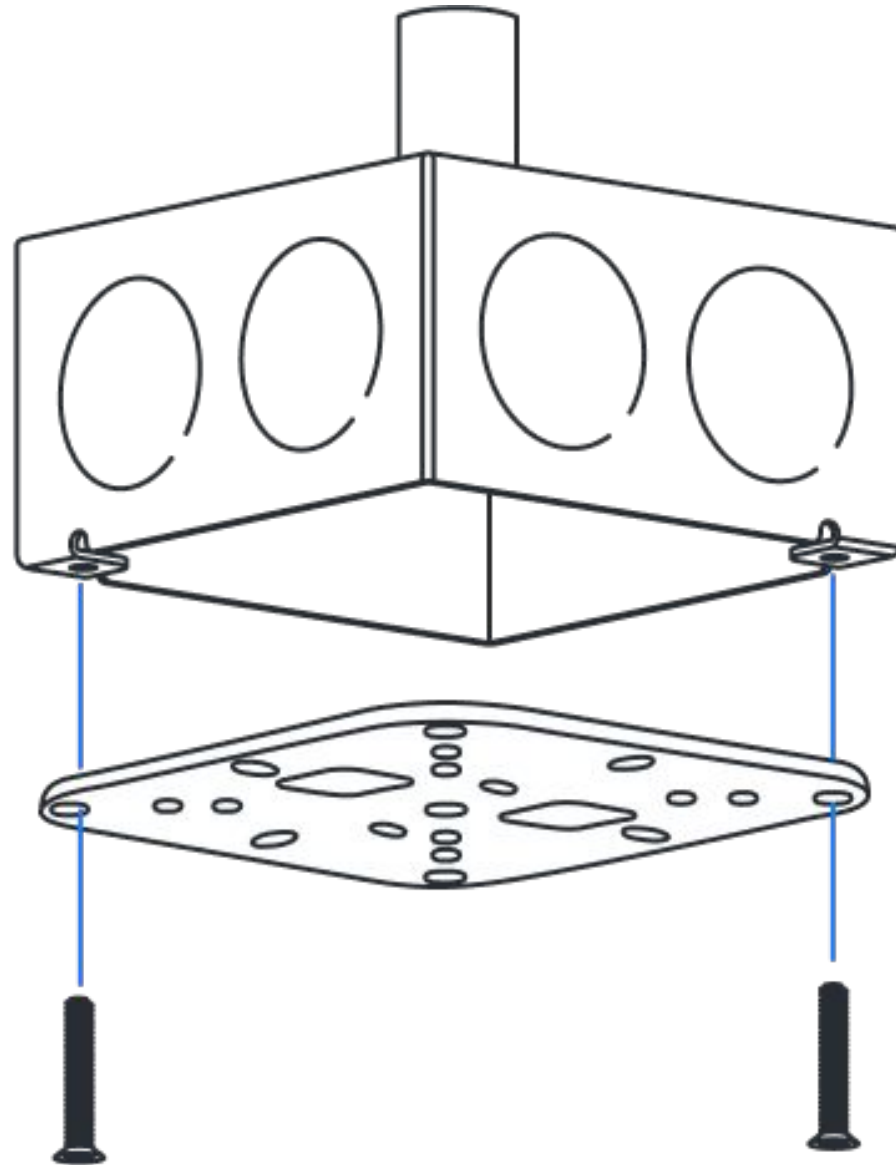

Step 2: Attach Entry LR Sensor

Attach the Entry LR Sensor to the threaded rod by inserting the threaded rod into the 1/4in-20 threads on the back of the Open Area sensor and twisting the sensor onto the rod until tight.

Screw the unit on all the way until it stops, then back it off to the prescribed location using the ethernet jack as the location guide.

Warning! Do not over-tighten as this can damage the unit.

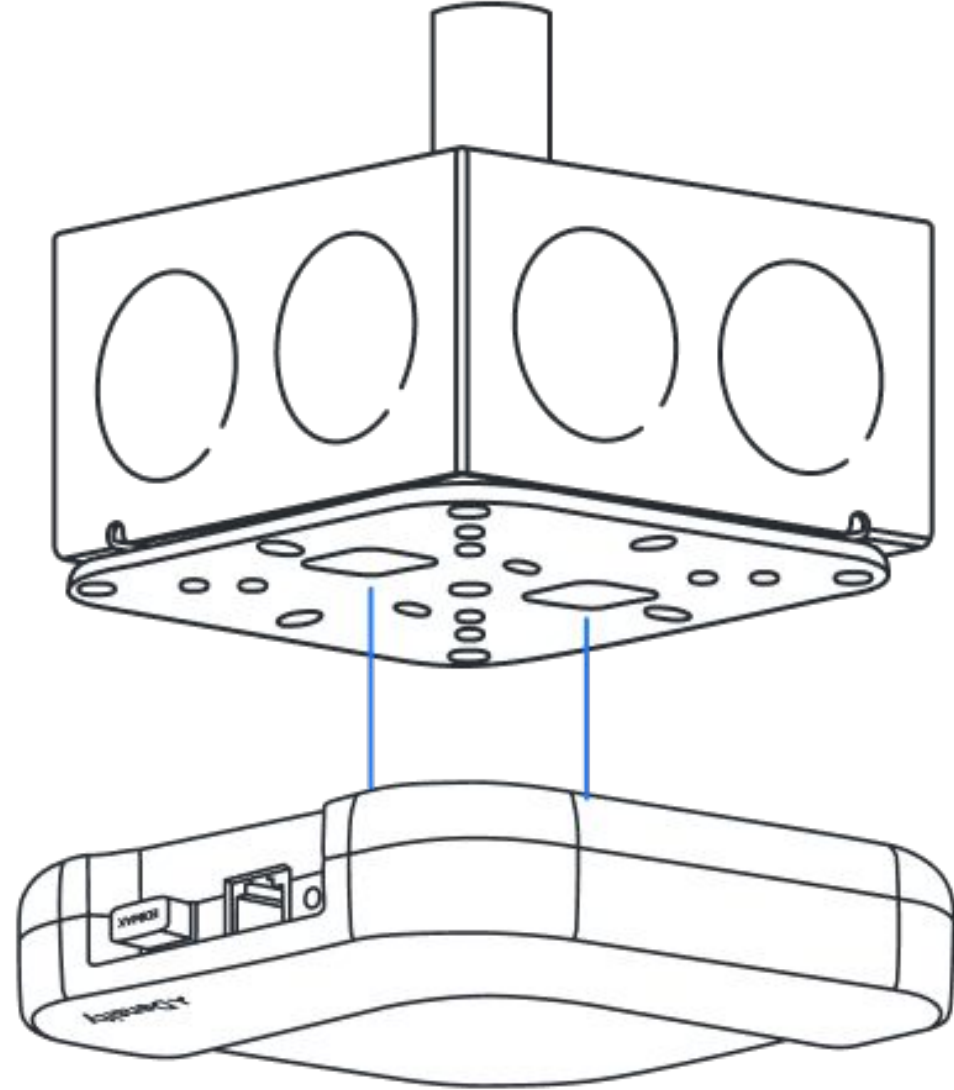
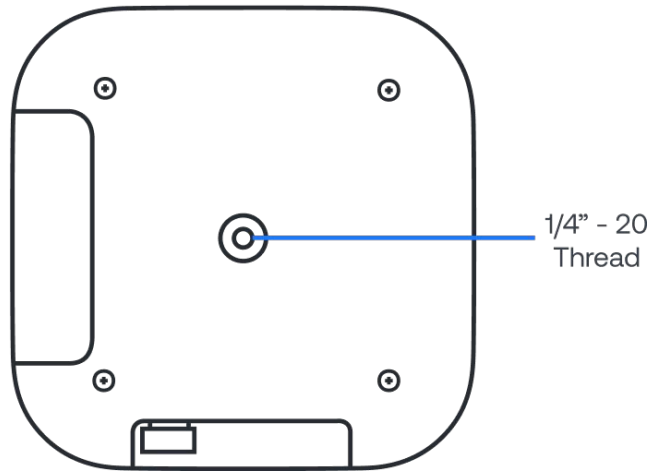

Step 3: Route cabling

The ethernet cable should be routed through the knockout holes in the junction box.

Be sure to use appropriate connectors or bushings to provide physical protection to the cable. Follow minimum bend radius requirements for the type of cable used.

