

Complete Installation Guide

Entry Sensor Version s5b Sensor



Contents

01 – In the Box

02 – Hardware

03 – Power

04 – Networking

05 – Entryway Guidelines

06 – Mounting Options

07 – Wall Mount

08 – Ceiling Mount - Toggle Anchor

09 – Ceiling Mount - Threaded Anchor

10 – Top of Frame Mount

11 – Bottom of Frame Mount

Product

- + Entry Sensor
- + Legal Information Booklet
- + Quick Start Guide

Wall mount kit

- + Wall Bracket (temporarily installed on the sensor)
- + Hex Key (2mm)
- + 2pcs #8 x 1.25in Rounded Head Screws
- + 2pcs Toggler Multi-Surface Anchors
- + Rubber Plug

Alternative Mounting (available for order)

- + Ceiling Mount Kit (895-0007)
- + Door Frame Mount Kit (895-0006)

Sensors

Wall Bracket (temporarily installed on the sensor)

Environmental specifications

- + Indoor Rated Only
- + Temperature: 32 - 95 F (0 - 35 C)
- + Relative humidity: 20% to 80% non-condensing

Indicators

Multi-color status LED

Unit weight

1.4lbs (0.59kg)

Certifications

Certified Class 1 Eye Safe Laser Device
+ EN/IEC 60825-1 2014 (2007 USA)
FCC Part 15 Subpart B Class A
+ Conducted Emissions (15.107)
+ Radiated Emissions (15.109)
CE Certification
IEC 60950-1:2009 Product Safety
EN 55032:2012
EN 301 489-1
RCM Mark (Australia & New Zealand)
RoHS2 Compliant
COO (country of origin): US
HS Code: 8471.90.0000
ECCN: EAR99

Dimensions & features

- + Enclosure Material: Anodized Aluminum
- + Window Material: IR PMMA Plastic
- + Removable Mount Arm
- + 1/4in-20 threads for ceiling mounting

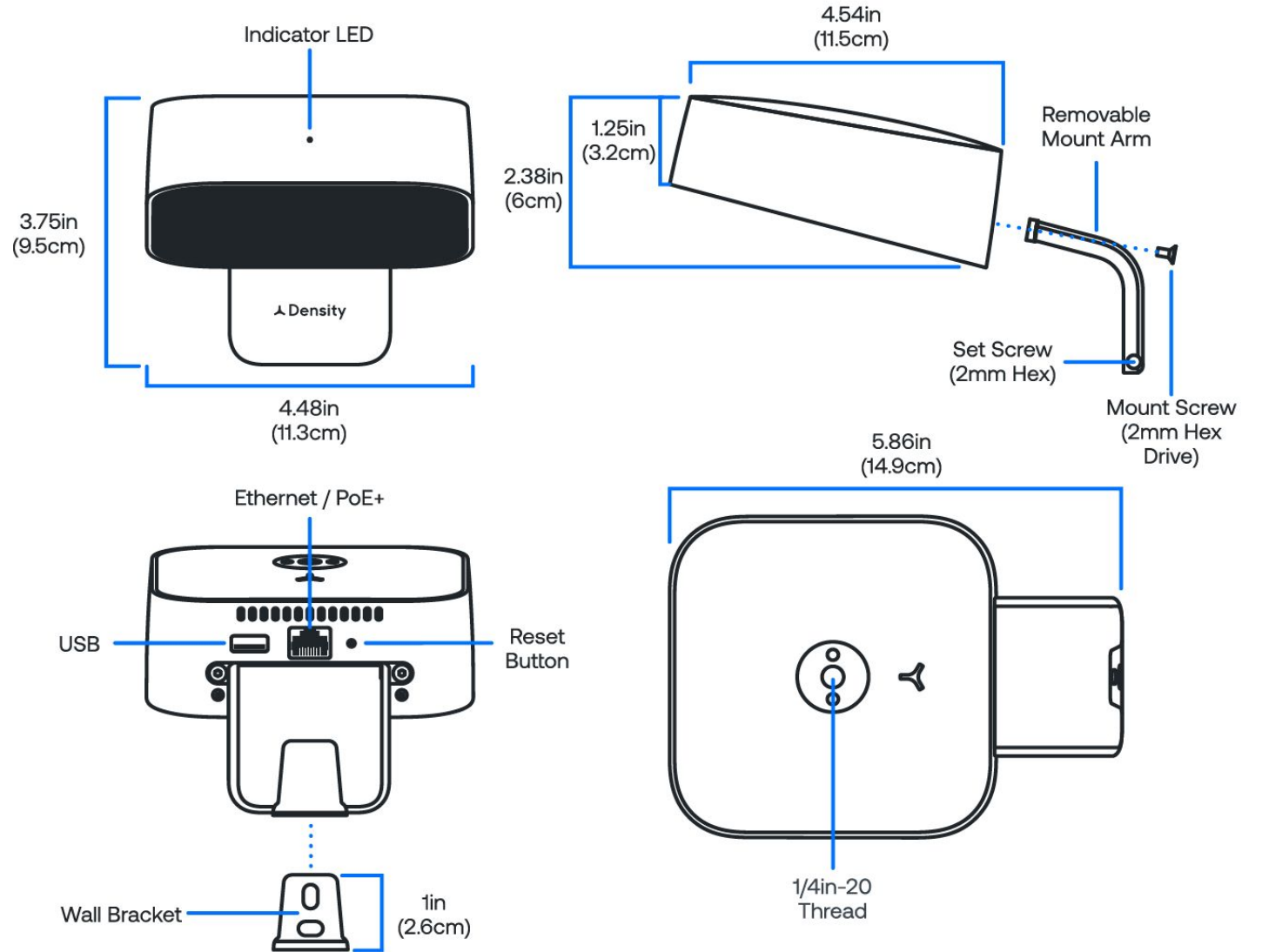

Interface

1x 10/100/1000 Base-T RJ45 interface

- + 1x USB 2.0 Port for WiFi/Bluetooth dongle
- + Reset Button

MAC address

Can be found on the side of the box that the sensor came in.

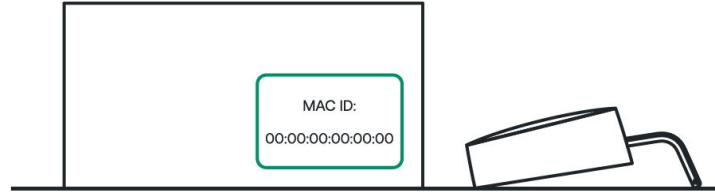

Serial Number Label

Appears on the sensor as shown.

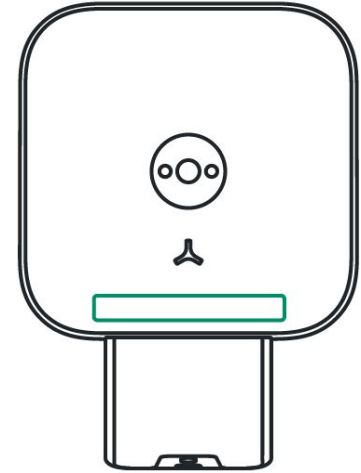

Temperature

The aluminum enclosure of the sensor is expected to be hot during operation. Density sensors comply with certification temperature requirements and do not pose any risk of burning the skin or causing fires. If the sensor has been powered on for an extended period of time, it is recommended to remove the power cable and allow the sensor to cool for at least 5 minutes before handling.

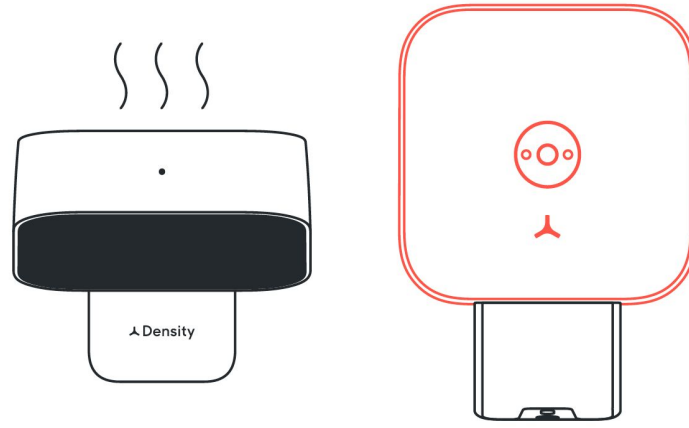

Window Cleanliness

Smudges, fingerprints, and excessive dust can affect sensor's ability to detect people. The sensor has a protective film designed to keep the window clean during installation. Remove the protective film after the installation is complete. Check the window for smudges or dust after the installation, and wipe clean with a microfiber cloth if necessary. Check the sensor window every few months for excessive dust build-up and wipe clean if necessary.

To clean your sensor, we recommend allowing the unit to cool down properly and diligently wiping down the black screen with a dry microfiber cloth or with minimal isopropyl alcohol. Be aware of any shifts during this process and place the sensor back in its original placement once complete.

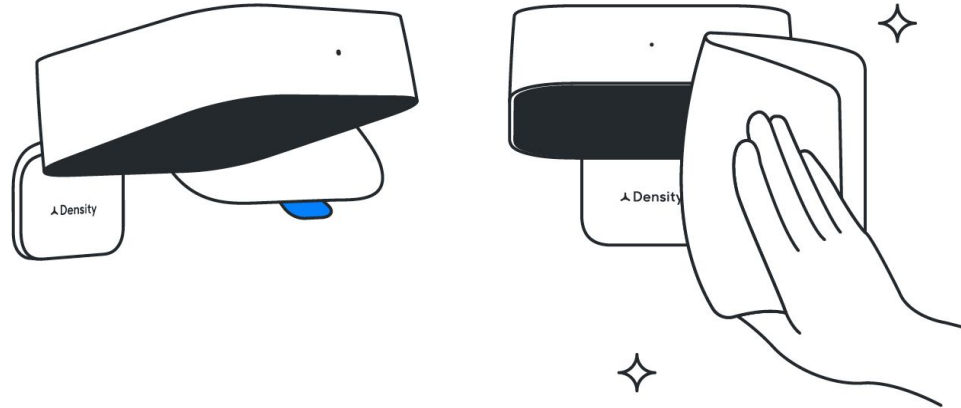

Resetting the sensor

To power reset the sensor to default factory settings, use the provided hex key or similarly thin object to press and hold the reset button (the reset lasts approximately 15 seconds). The sensor must be plugged in and connected to power to reset.

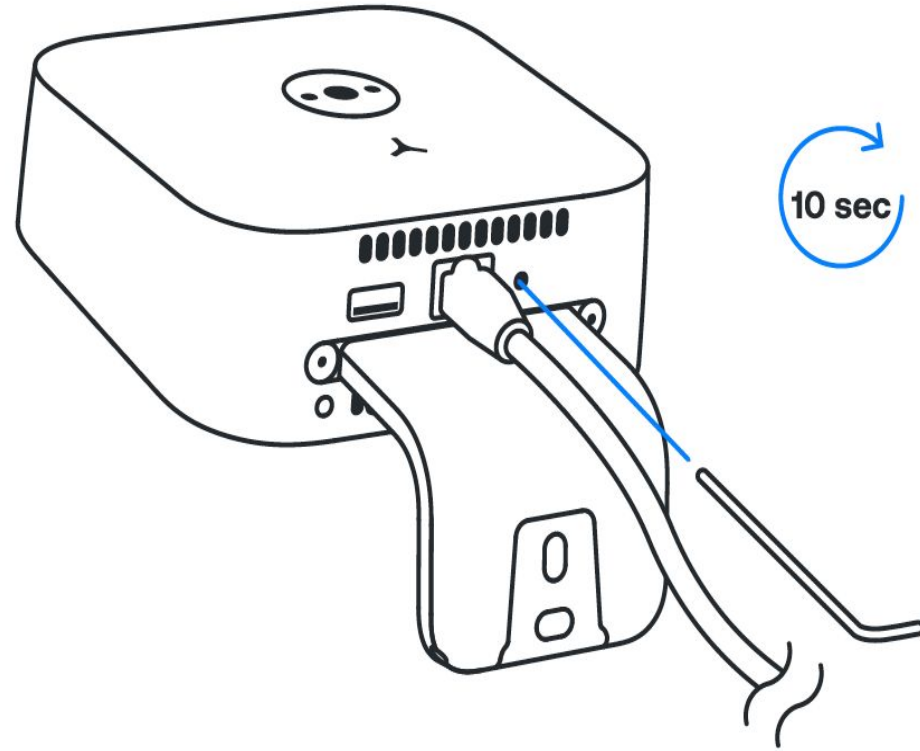

Power requirements

Density sensors require 802.3at PoE+ (Power over Ethernet) and a constant 30W power budget.

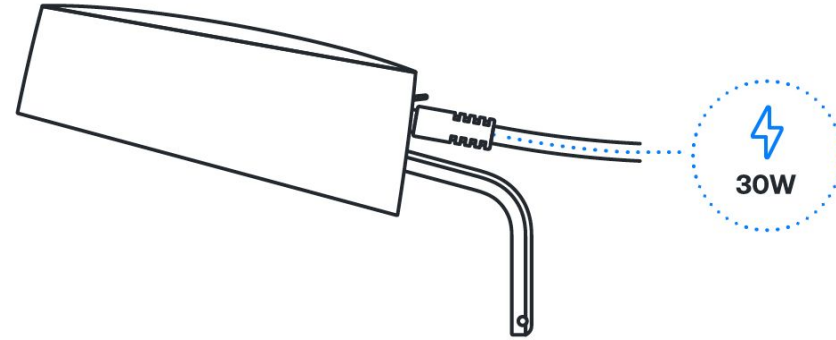

Cable requirements

The sensor requires a Cat 5e or later ethernet cable (not included).

Note: Cable must not exceed 328 feet (100 meters).

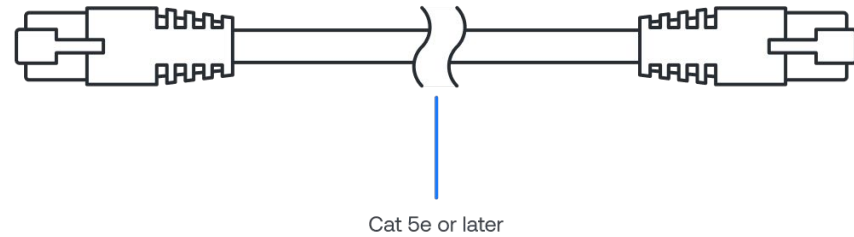

Option 1 – PoE switch

Connect one end of a Cat 5e or later ethernet cable to an 802.3at (PoE+ Type 2) compliant network switch capable of providing 30W per port. Plug the other end of the ethernet cable into the sensor.

Each sensor requires 30W at the PSE (Power Supply Equipment / Switch) per 802.3at PoE+ Type 2 spec. Please ensure the total power draw from your switch does not exceed the limit of the power source. (For example, if you have a 24-port 500W switch, you can support up to 16 sensors simultaneously, assuming no other load on the remaining ports).

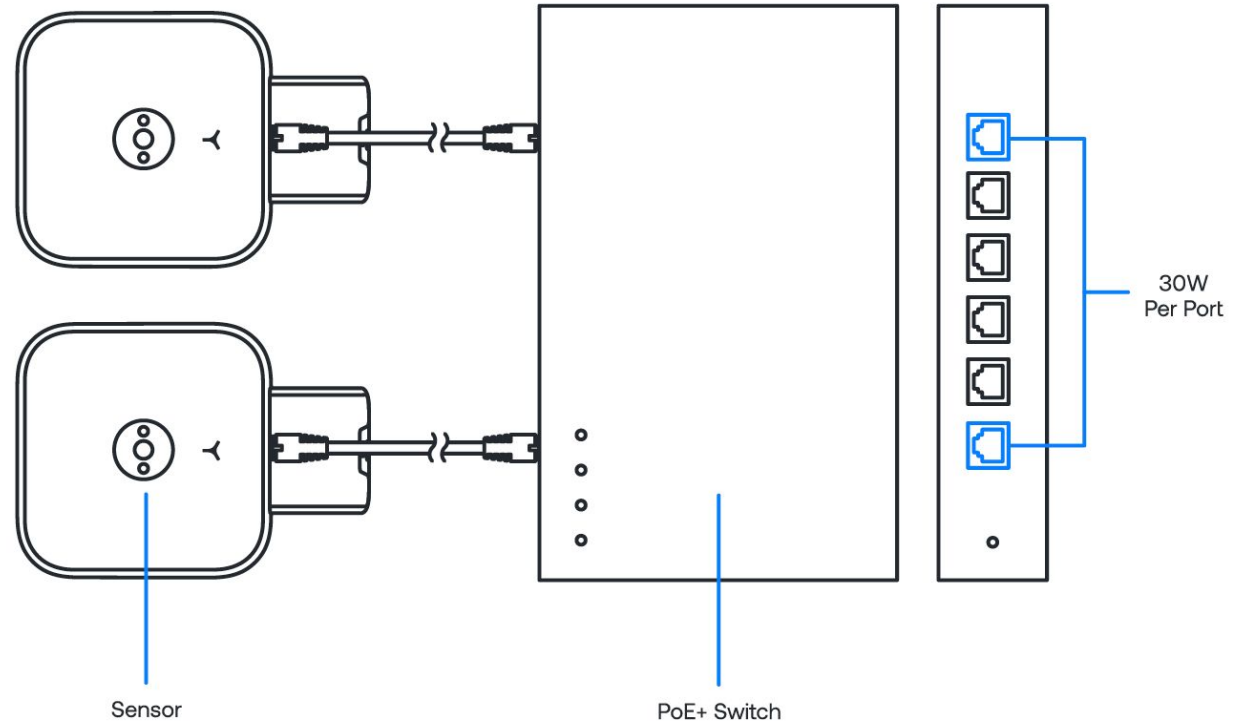

Option 2 – PoE injector using ethernet

Plug the 30W PoE+ Injector into any standard wall outlet. Plug one end of a Cat 5e or later ethernet cable into a cradlepoint/router or non-PoE+ switch. Plug the other end of the cable into the Data In port located on the bottom of the Injector. Plug an additional ethernet cable into the Data & Power Out port located on the base of the injector. Plug the other end of the ethernet cable into the sensor.

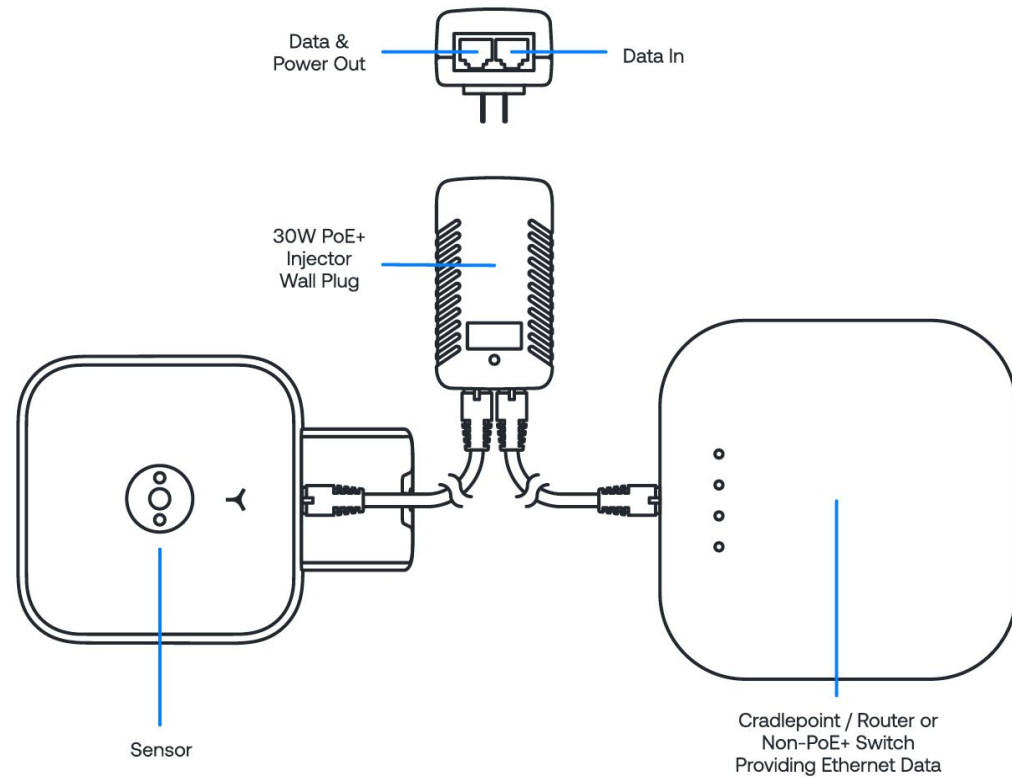

Networking basics

Density devices require internet connectivity to pass data to the web application.

Recommended Configuration: Wired ethernet connectivity configured via DHCP with internal NTP and internal DNS servers. IPv4 is required.

Networks that are not supported:

- + Captive portal
- + Proxy
- + WPA2 Enterprise
- + Hidden Networks *
- + 5GHz WiFi networks

** Hidden networks can be used if temporarily made transparent while we configure the devices.*

If you have a corporate firewall

You will need to safelist the device MAC addresses (the MAC addresses can be found on the outside of the packaging box for the device). You may also have to safelist the following addresses to ensure the device is able to communicate outside of your corporate network:

- + *.density.io (port 443)
- + *.amazonaws.com
- + *.gstatic.com
- + *connman.net
- + ntp port (port 123) must be open
- + If internal DNS is not available then external DNS servers 8.8.8.8 and 8.8.4.4 will be used and port 53 must be open

Density does not currently support IP address safelisting. A list of exact API subdomains is available by request.

Setup App

Used to configure and troubleshoot units. iOS and Android application available - Go to mobile.density.io to download.

Sensor LED status indicator

The sensor has an indicator LED located on the front of the sensor. The color chart to the right explains the meaning of each color, defines any issues, and lists what actions to take if necessary.

If the recommended action does not resolve the LED light error status, factory reset the sensor. To reset, press and hold the reset button on the back of the sensor until the LED light starts flashing white. If the issue persists, please contact support@density.io.

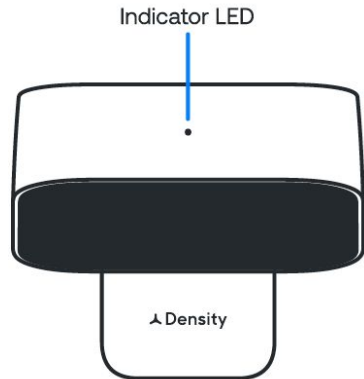

No Light	No Light	•	Sensor is not receiving power	Check that sensor is plugged in and receiving power from the source
White	Solid	•	Operating Normally	No action needed
White	Flashing	• • •	Locate sensor function	Indicates which sensor you're interacting with when using "Locate" in the mobile app
Blue	Solid	•	Ready to be Provisioned	Typical state out of the box once sufficient power is provided.
Blue	Flashing	• • •	Connected to Bluetooth	No action needed FYI: LED blinks while the app is connected to the sensor
Orange	Solid	•	Factory OS	Contact support@density.io with serial numbers
Orange	Flashing	• • •	Low Power Mode	Confirm switch is PoE+ with at least 16W of power per port. Test ethernet cables.
Purple	Solid	•	Sensor cannot connect to the Density Se	Provision sensor via mobile app (mobile.density.io). If not resolved, run "Validate" in app and email results to support@density.io
Purple	Flashing	• • •	Server cannot connec to DNS	Verify DNS is available on VLAN. If no internal DNS server, review corporate firewalls to verify device can reach default DNS servers
Red	Solid	•	No Network Configuration	WiFi: Use the Spaces app to create a network template Ethernet: Verify DHCP server is available on VLAN
Red	Flashing	• • •	No Dongle Present or No ToF (reserved)	Occurs when device has not yet been provisioned and the Bluetooth Dongle is absent. Plug in Bluetooth Dongle to provision.

Entryway Guidelines

Number of Sensors

To maintain an accurate count of a space, you need to install a sensor above every entryway to that space. The sensor is designed for indoor use only.

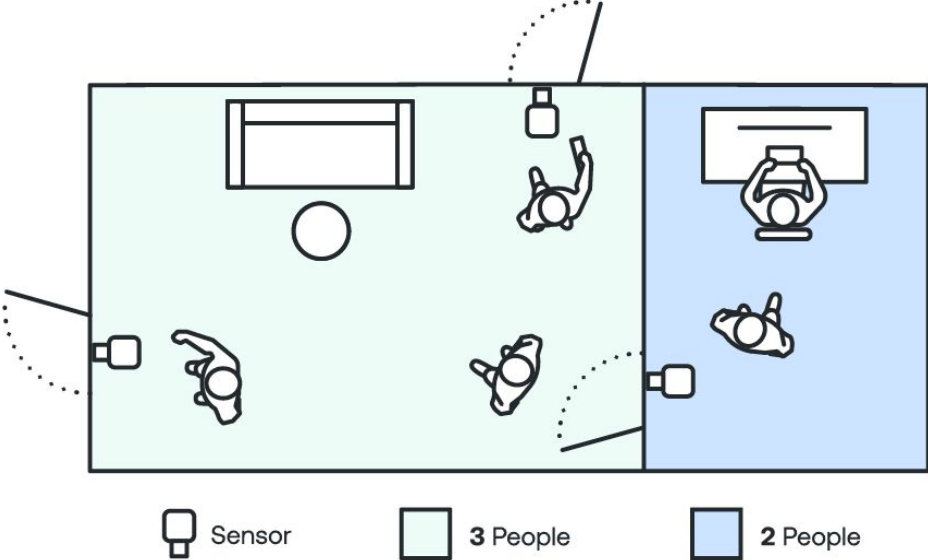

Field of View/Placement

The total detection area beneath the sensor is called the FOV (Field of View). The entryway needs adequate FOV coverage to count people. Refer to the Install Height Chart to determine the minimum sensor height for your entryway. The sensor should be centered horizontally above the entryway or hallway to ensure people are detected within the field of view.

Note: There is an exception to this rule if the sensor height is 100 in (254 cm) or below and the sensor is mounted over a single swinging door. In this case, a sensor offset of 10 in (25.4 cm) will be needed. See Single Door Specifics Section.

The sensor cannot be mounted inside the ceiling, on a side wall facing the entryway, or in the corner of a room.

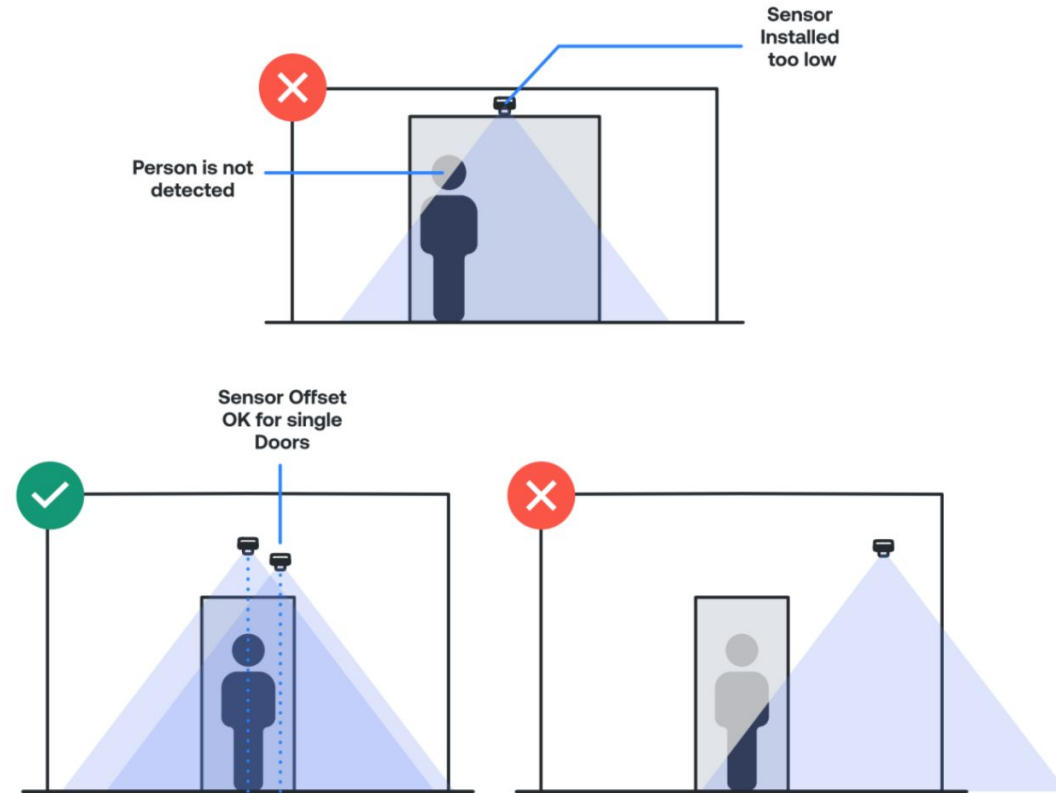

Trigger Line

People are counted as they cross an invisible barrier known as the Trigger Line. The sensor must be installed as close to the entryway as possible (not exceeding 12 in from the door) to ensure people cross this line.

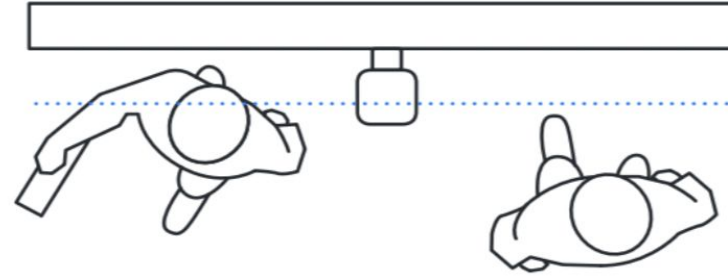

Install Height

The higher the sensor height, the greater the entryway FOV (Field of View) coverage. Install the sensor at its maximum height of 9 ft 10 in (118 in or 300 cm) for optimal entryway coverage. The minimum install height for the sensor is 7 ft 8 in (92 in or 234 cm). Refer to the Install Height Chart.

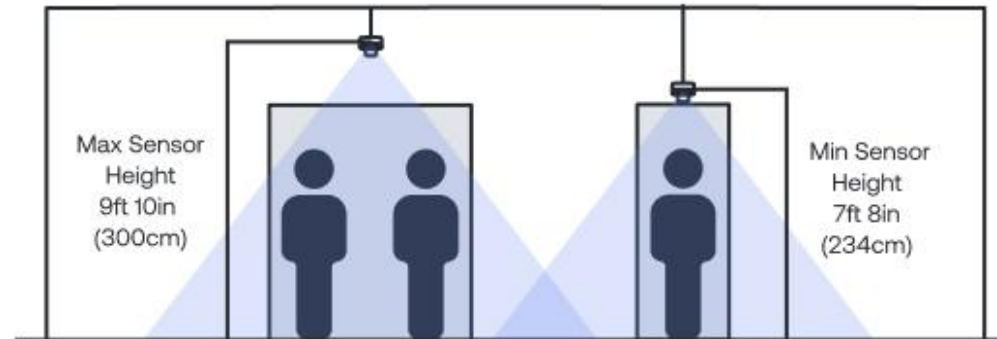

Sensor Height

Adequate sensor height is critical to ensure proper FOV coverage of the entryway. The Sensor Height is determined by measuring the distance between the front edge of the sensor or black window and the ground. The Wall Bracket Height is the distance between the bottom of the wall bracket and the floor. Sensor Height can be determined for wall-mounted installations by measuring the Wall Bracket Height and adding 2.5 in (6.3 cm) to that measurement.

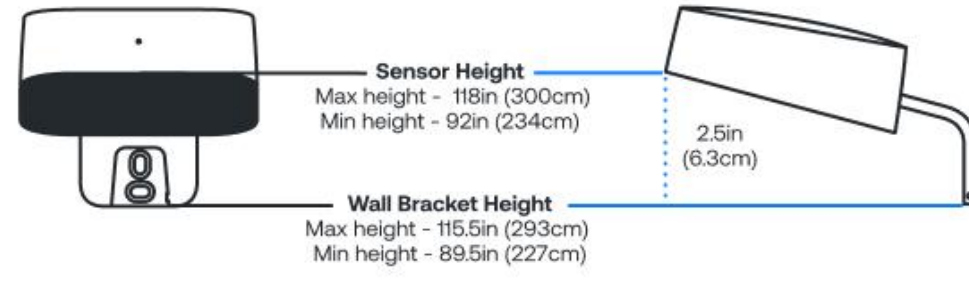
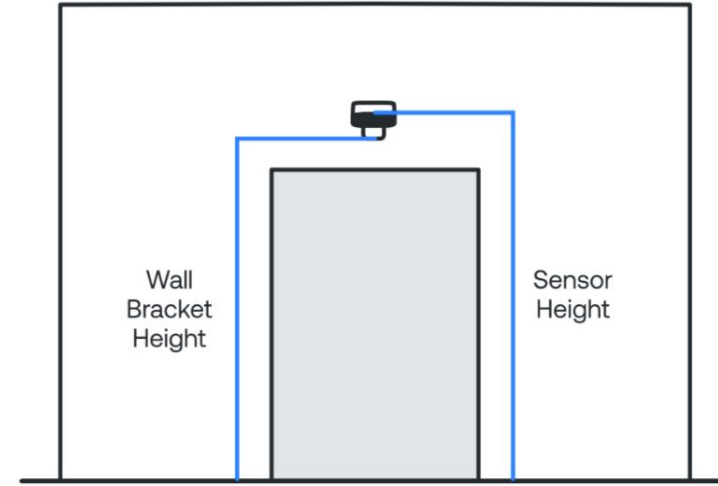

Threshold Width

To determine the Threshold Width of the entryway, measure the open space a person can physically walk through. Doors with handles can restrict the walkable pathway and reduce the FOV coverage requirements. For entryways with doors, open the door fully and measure the width of the unobstructed path through the doorway. For hallways or entryways with no doors, measure the distance from wall to wall.

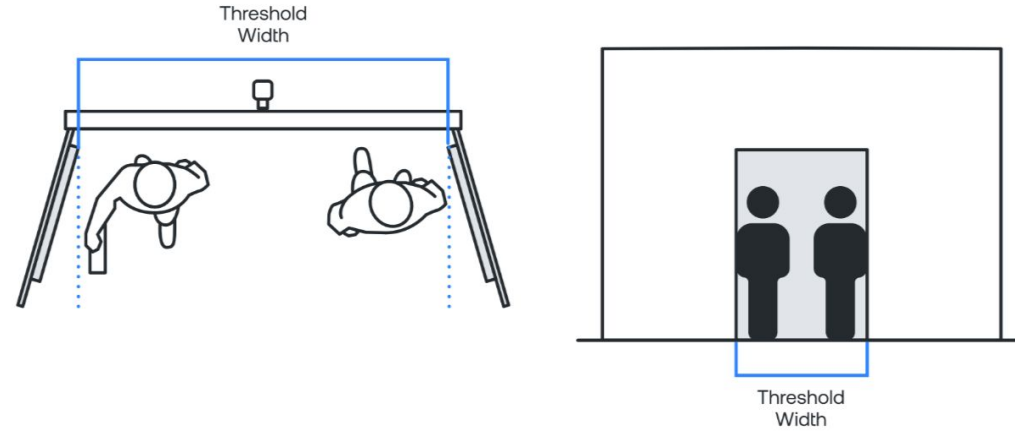

Sensor Orientation

The sensor must be positioned parallel to the flow of traffic. The sensor should point away from the wall if mounted near an entryway.

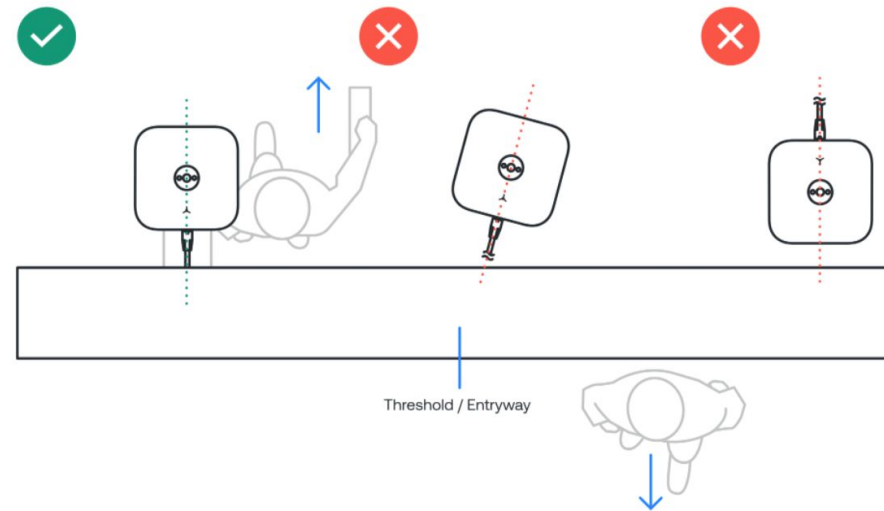

Sensor Positioning

When mounting the sensor to the ceiling, make sure that the sensor is not mounted too close or too far away from the entryway/threshold. The optimal position for the threaded rod is 3.5 in (8.9 cm) away from the threshold/entryway.

In some cases, obstructions or other environmental issues may call for the sensor to be installed outside these guidelines. Any deviation from the guidelines should be under the direct consultation of an account representative.

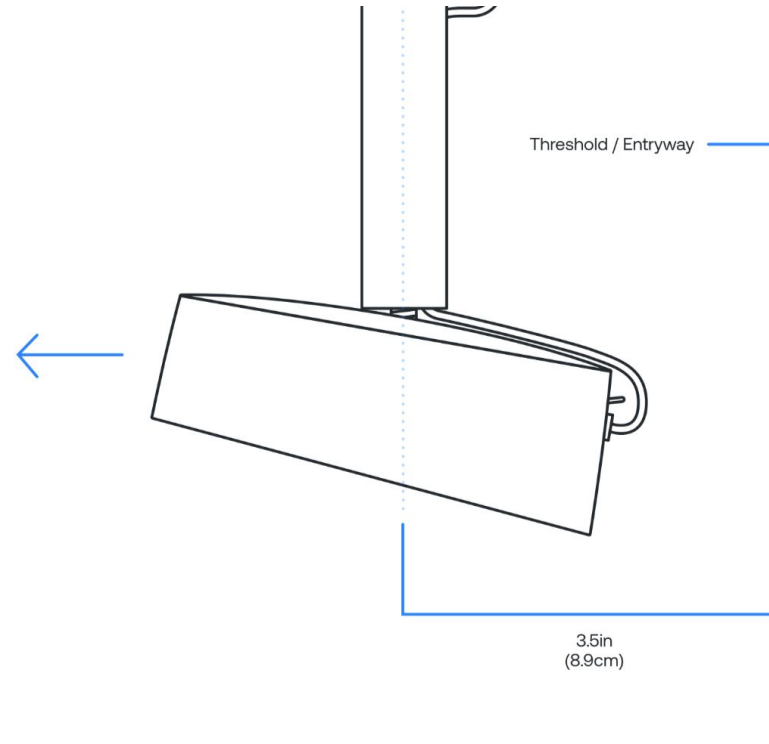

Exit Signs

Exit signs should be level with the front edge of the sensor or higher to avoid any light or FOV interference. If the exit sign is level with the sensor's front edge, ensure at least 6 in (15 cm) of space between the exit sign and the wall.

If an exit sign position falls outside these guidelines, reach out to your account representative to verify that there is no FOV or light interference.

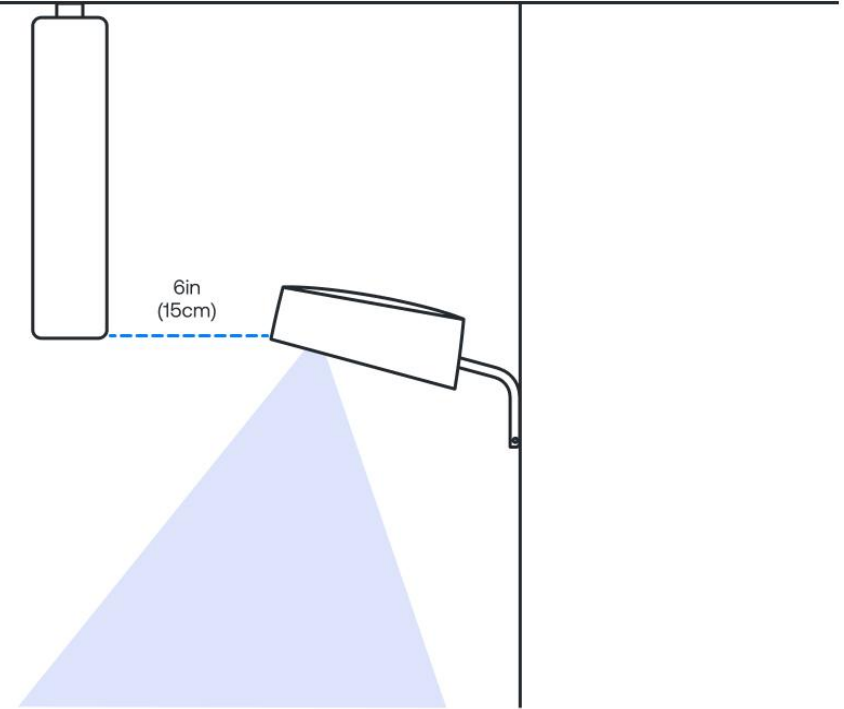

Door Frames

Installing the sensor near a door frame can cause potential FOV interference. If your installation requires a door frame mount (section 9,10), position the sensor towards the front edge of the door frame.

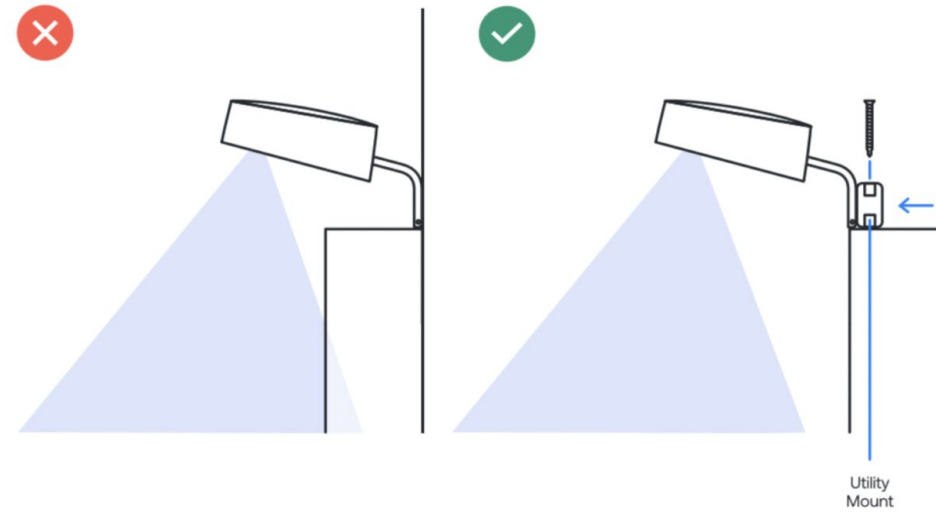

Door Swing

The sensor should be mounted on the non-door swing side of the entryway when possible.

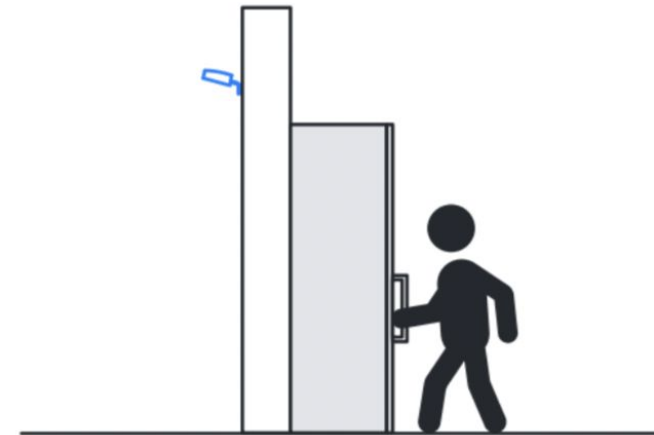

Single Door Specifics

For some single doors, the optimal sensor placement is closer to the handle side of the door. Mount the sensor approximately 10 in (25.4 cm) away from the handle side of the door if your single door meets any of the below criteria:

- + The sensor height is 100 in (254 cm) or less
- + A door closer swings under the sensor

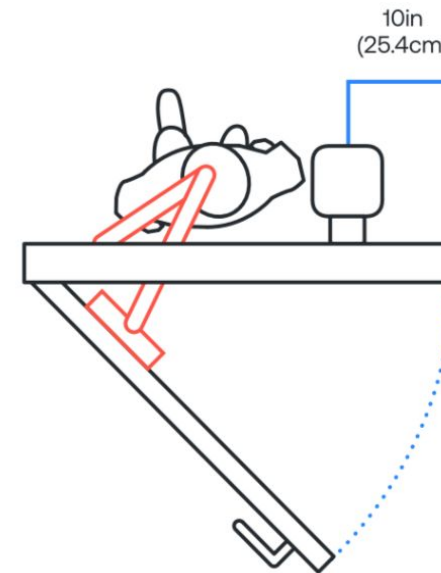
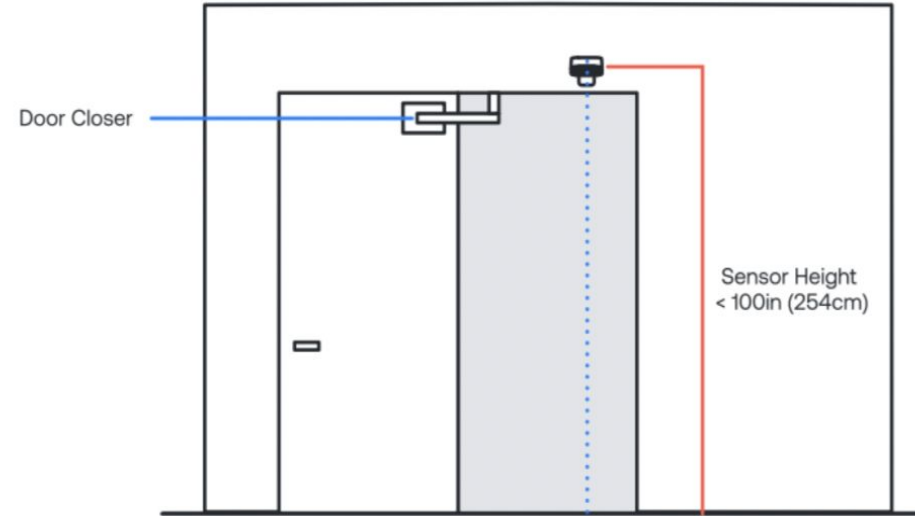

Black Tape

If the sensor is mounted too close to a swinging door, the IR light emitting from the sensor will bounce off the top of the door and cause interference with the sensor. If the door swings underneath the sensor, apply a strip of black painter's tape or gaffer's tape to the entire top surface of the door. Make sure to trim off any excess tape. The tape will help absorb the emitted sensor light and mitigate any interference.

** Metal doors cause extreme light reflection at any sensor height. If your door is made of metal, apply a strip of black tape to the entire top surface of the door regardless of sensor height.*

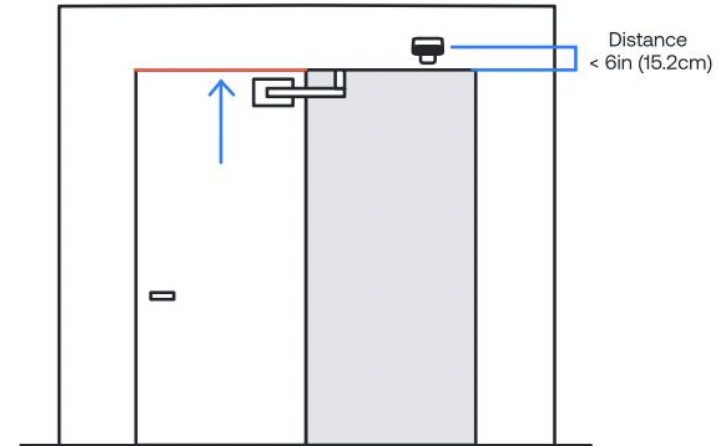

Door Swing Offset

Doors that swing in both directions and are flush with the ceiling require the sensor to be ceiling-mounted and offset away from the swinging door to avoid collision. The maximum offset distance for the sensor is 14 in (35.6 cm), measured from the wall to the front edge of the sensor.

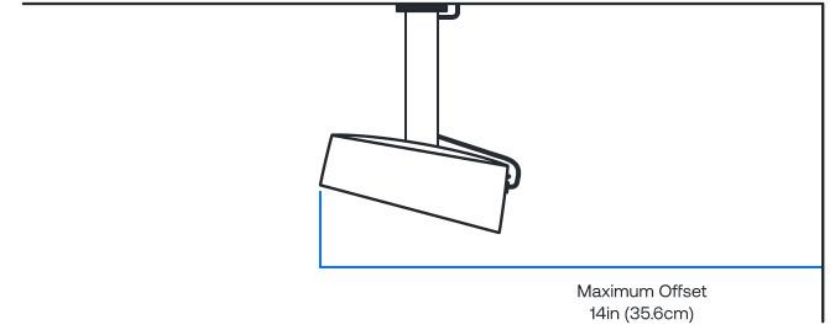
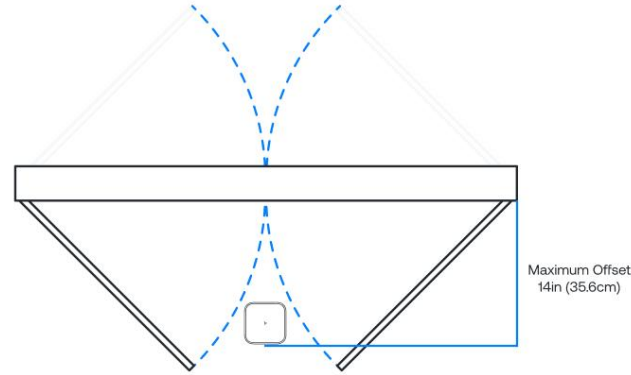

Overhang

Some doorways have a structural overhang which would prevent the sensor from being installed above the door at the optimal mounting height. The sensor can be offset from the door and mounted above the opening of the overhang. The opening will act as an extension of the door entryway. For the overhang mount to work, there needs to be structural side walls to confine human movement to the area beneath the sensor.

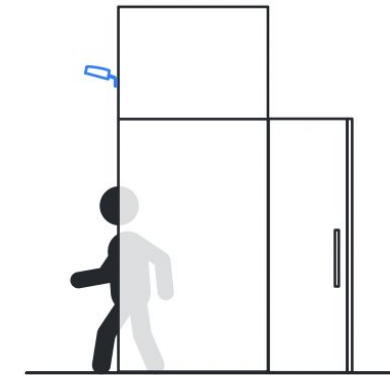
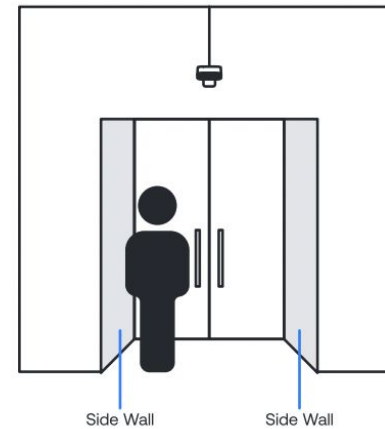

Standard Clearance

For standard wall mount installations (section 5), a minimum of 6.75 in (17.1 cm) of unobstructed vertical wall space is recommended above the entryway. This allows enough clearance to mount the sensor and for the sensor to receive adequate airflow to operate as expected.

The recommended clearance between the front edge of the sensor and the ceiling is 3 in (7.62 cm). This will guarantee device performance up to 35C ambient temperature.

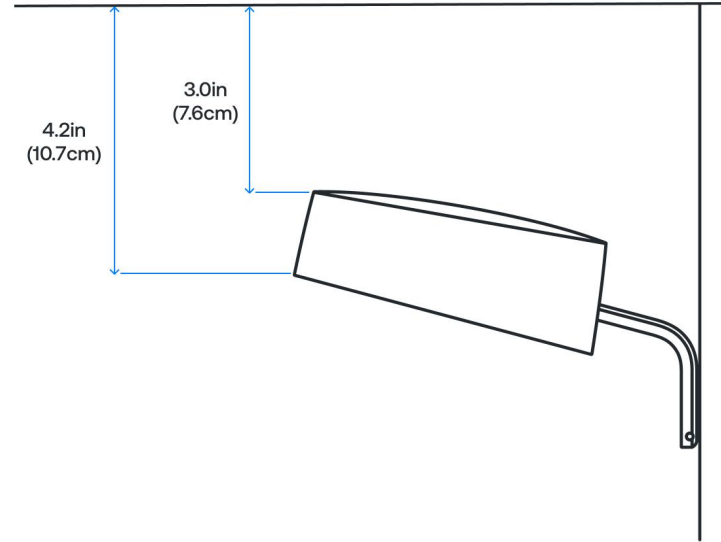

Minimum Clearance

For installation situations that require less headroom, the minimum gap from the top of the front edge to the ceiling is 0.5 in (1.3 cm). This gap will guarantee device performance up to 30C ambient temperature.

The sensor cannot hang below the entryway for ceiling mount installations if the door swings toward the sensor, as the door will make contact. If the door swings toward the sensor, the sensor must be offset away from the door (see Door Swing Offset section).

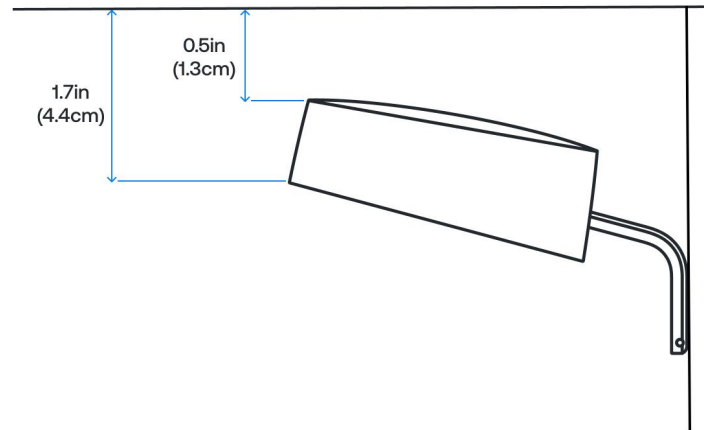

Hallways

In some scenarios, sensors can be suspended over hallways using a threaded rod and a Ceiling Mount Kit (section 8,9).

Make sure to follow the Install Height Chart for hallway installs.

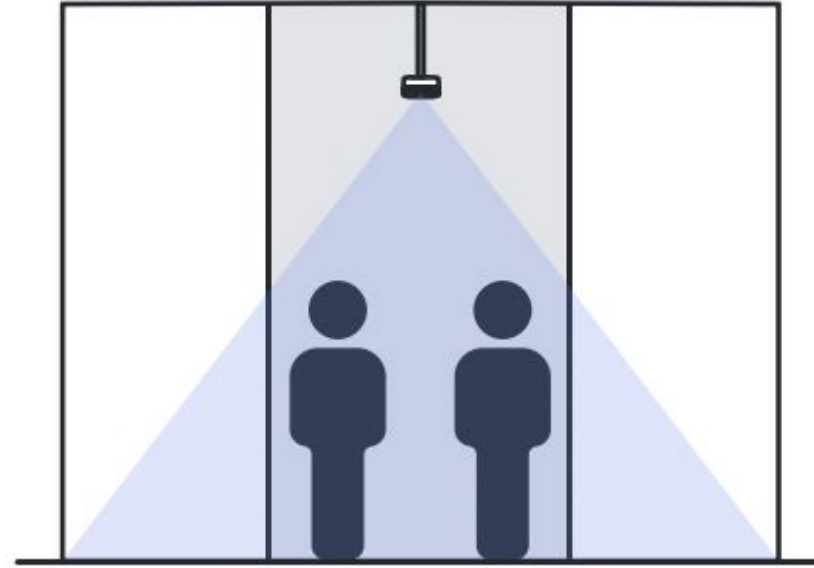

Install Height Chart - Single Sensor

To determine the necessary sensor height for a given threshold, measure the threshold width (the physical opening a person can walk through), then refer to the Install height Chart for the minimum sensor height. Use the minimum sensor height as the starting measurement for the Mounting Zone. The upper measurement of the mounting zone will be the overall maximum sensor install height of 118 in (300 cm). Mount the sensor near the center of the Mounting Zone.

Additional sensors may be needed if your entryway falls outside these guidelines. Please reach out to your account representative for assistance.

** If the sensor height is at 100 in (254 cm) or below, and the sensor is being mounted over a single swinging door, a sensor offset of 10 in (25.4 cm) will be needed. The sensor is offset to be positioned over the handle side of the door, so coverage is emphasized on the side that people walk through the door. See Single Door Specifics.*

Install Height Chart			
Standard (in)		Metric (cm)	
Threshold Width	Min Sensor Height	Threshold Width	Min Sensor Height
≤ 40in	*92in (7ft 8in)	≤ 101cm	*232cm
≤ 45in	*93in	≤ 114cm	*236cm
≤ 50in	*96in	≤ 127cm	*244cm
≤ 55in	99in	≤ 140cm	251cm
≤ 60in	102in	≤ 153cm	259cm
≤ 65in	105in	≤ 166cm	266cm
≤ 70in	108in	≤ 178cm	274cm
≤ 75in	111in	≤ 191cm	282cm
≤ 80in	114in	≤ 203cm	290cm
≤ 85in	117in	≤ 216cm	297cm
≤ 90in (7ft 6in)	118in (9ft 10in)	≤ 229cm	300cm
Minimum Sensor Height - 92in (7ft 8in) Maximum Sensor Height - 118in (9ft 10in)		Minimum Sensor Height - 232cm Maximum Sensor Height - 300cm	

Multiple Sensors

If the entryway width is too wide and the sensor cannot be mounted high enough for ample FOV coverage, an additional sensor or two can be added. While we recommend using fewer sensors when possible, one entryway can support up to three sensors.

As shown below, multiple sensors should be mounted in line and parallel to each other.

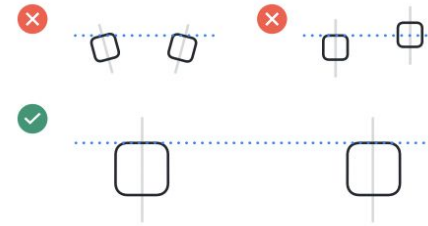
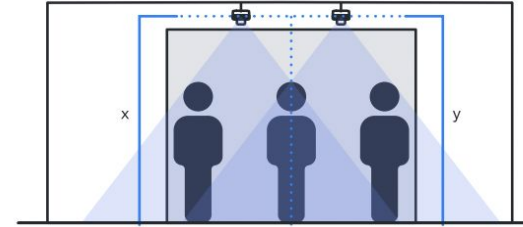

Multi-Unit Spacing - Two Sensors

For two-sensor installs, the distance between the center point of the entryway and the center point of the left and right sensors should be equal ($a = b$). The distance from the ground to the sensors should also be equal ($x = y$).

Record the distance between sensor center points, sensor height, and both sensor serial numbers.

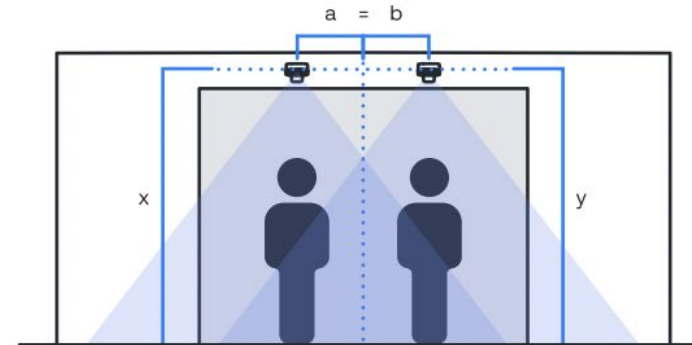

Install Height / Spacing Chart - Two Sensors

The Install Height / Spacing Chart lists the minimum sensor height requirements for various threshold widths as well as the required distance between sensors.

To use the chart, measure the threshold width (the physical opening a person can walk through), then look at the chart for the minimum required install height. Space the sensors over the threshold according to the Distance Between Sensors section of the chart. The minimum allowable distance between sensors is 22 in (56cm), and the maximum allowable distance between sensors is 67 in (170 cm).

If needed, please contact your account representative for a walk-through of the Install Height / Spacing Chart.

2 Sensors - Standard (in)																
Threshold Width	Min Sensor Height	Sensor Heights														
		92in	94in	96in	98in	100in	102in	104in	106in	108in	110in	112in	114in	116in	118in	
		Distance Between Sensors														
≤ 68in	*92in		25in	28in	30in	34in	37in	40in	43in	46in	49in	52in	55in	58in	61in	64in
≤ 74in	94in		N/A	28in	30in	34in	37in	40in	43in	46in	49in	52in	55in	58in	61in	64in
≤ 80in	96in		N/A	N/A	30in	34in	37in	40in	43in	46in	49in	52in	55in	58in	61in	64in
≤ 86in	98in		N/A	N/A	N/A	34in	37in	40in	43in	46in	49in	52in	55in	58in	61in	64in
≤ 92in	100in		N/A	N/A	N/A	N/A	37in	40in	43in	46in	49in	52in	55in	58in	61in	64in
≤ 98in	102in		N/A	N/A	N/A	N/A	N/A	40in	43in	46in	49in	52in	55in	58in	61in	64in
≤ 104in	104in		N/A	N/A	N/A	N/A	N/A	N/A	43in	46in	49in	52in	55in	58in	61in	64in
≤ 110in	106in		N/A	N/A	N/A	N/A	N/A	N/A	N/A	46in	49in	52in	55in	58in	61in	64in
≤ 116in	108in		N/A	N/A	N/A	N/A	N/A	N/A	N/A	N/A	49in	52in	55in	58in	61in	64in
≤ 122in	110in		N/A	N/A	N/A	N/A	N/A	N/A	N/A	N/A	N/A	52in	55in	58in	61in	64in
≤ 128in	112in		N/A	N/A	N/A	N/A	N/A	N/A	N/A	N/A	N/A	N/A	55in	58in	61in	64in
≤ 134in	114in		N/A	N/A	N/A	N/A	N/A	N/A	N/A	N/A	N/A	N/A	N/A	58in	61in	64in
≤ 140in	116in		N/A	N/A	N/A	N/A	N/A	N/A	N/A	N/A	N/A	N/A	N/A	N/A	61in	64in
≤ 146in	*118in		N/A	N/A	N/A	N/A	N/A	N/A	N/A	N/A	N/A	N/A	N/A	N/A	N/A	64in
*Minimum Sensor Height - 92in (7ft 8in) *Maximum Sensor Height - 118in (9ft 10in)																

2 Sensors - Metric (cm)																
Threshold Width	Min Sensor Height	Sensor Heights														
		232cm	239cm	245cm	249cm	254cm	259cm	264cm	269cm	274cm	279cm	284cm	289cm	295cm	300cm	
		Distance Between Sensors														
≤ 157cm	*232cm		63cm	71cm	76cm	86cm	94cm	101cm	109cm	117cm	124cm	132cm	140cm	147cm	155cm	162cm
≤ 173cm	234cm		63cm	71cm	76cm	86cm	94cm	101cm	109cm	117cm	124cm	132cm	140cm	147cm	155cm	162cm
≤ 188cm	239cm		N/A	71cm	76cm	86cm	94cm	101cm	109cm	117cm	124cm	132cm	140cm	147cm	155cm	162cm
≤ 203cm	245cm		N/A	N/A	76cm	86cm	94cm	101cm	109cm	117cm	124cm	132cm	140cm	147cm	155cm	162cm
≤ 218cm	249cm		N/A	N/A	N/A	86cm	94cm	101cm	109cm	117cm	124cm	132cm	140cm	147cm	155cm	162cm
≤ 234cm	254cm		N/A	N/A	N/A	N/A	94cm	101cm	109cm	117cm	124cm	132cm	140cm	147cm	155cm	162cm
≤ 249cm	259cm		N/A	N/A	N/A	N/A	N/A	101cm	109cm	117cm	124cm	132cm	140cm	147cm	155cm	162cm
≤ 264cm	264cm		N/A	N/A	N/A	N/A	N/A	N/A	109cm	117cm	124cm	132cm	140cm	147cm	155cm	162cm
≤ 279cm	269cm		N/A	N/A	N/A	N/A	N/A	N/A	N/A	117cm	124cm	132cm	140cm	147cm	155cm	162cm
≤ 295cm	274cm		N/A	N/A	N/A	N/A	N/A	N/A	N/A	N/A	124cm	132cm	140cm	147cm	155cm	162cm
≤ 310cm	279cm		N/A	N/A	N/A	N/A	N/A	N/A	N/A	N/A	N/A	132cm	140cm	147cm	155cm	162cm
≤ 325cm	284cm		N/A	N/A	N/A	N/A	N/A	N/A	N/A	N/A	N/A	N/A	140cm	147cm	155cm	162cm
≤ 340cm	289cm		N/A	N/A	N/A	N/A	N/A	N/A	N/A	N/A	N/A	N/A	N/A	147cm	155cm	162cm
≤ 356cm	295cm		N/A	N/A	N/A	N/A	N/A	N/A	N/A	N/A	N/A	N/A	N/A	N/A	155cm	162cm
≤ 371cm	*300cm		N/A	N/A	N/A	N/A	N/A	N/A	N/A	N/A	N/A	N/A	N/A	N/A	N/A	162cm
*Minimum Sensor Height - 232cm (2.32m) *Maximum Sensor Height - 300cm (3m)																

Multi-Sensor Spacing - Three Sensors

For three sensor installs, the distance between the center point of the centrally mounted sensor and the center point of the left and right sensors should be equal ($a = b$). The distance from the ground to the sensors should also be equal ($x = y$).

Record the distance between sensor center points, sensor height, and both sensor serial numbers.

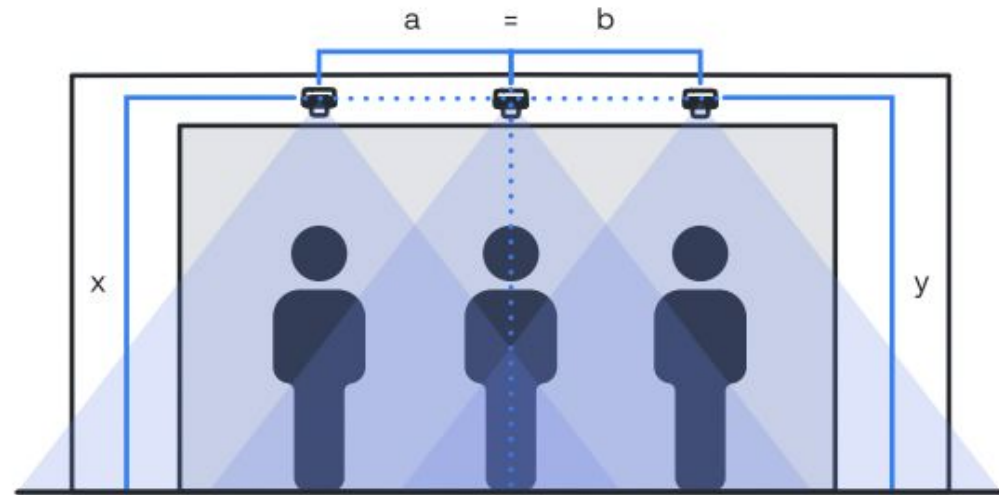

Install Height / Spacing Chart - Three Sensors

The Install Height / Spacing Chart lists the minimum sensor height requirements for various threshold widths as well as the required distance between sensors.

To use the chart, measure the threshold width (the physical opening a person can walk through), then look at the chart for the minimum required install height. Space the sensors over the threshold according to the Distance Between Sensors section of the chart. The minimum allowable distance between sensors is 22 in (56 cm), and the maximum allowable distance between sensors is 67 in.

3 Sensors - Standard (in)																	
Threshold Width	Min Sensor Height	Sensor Heights															
		90in	92in	94in	96in	98in	100in	102in	104in	106in	108in	110in	112in	114in	116in	118in	120in
		Distance Between Sensors															
≤ 84in	90in	22in	25in	28in	30in	34in	37in	40in	43in	46in	49in	52in	55in	58in	61in	64in	67in
≤ 93in	92in	N/A	25in	28in	30in	34in	37in	40in	43in	46in	49in	52in	55in	58in	61in	64in	67in
≤ 102in	94in	N/A	N/A	28in	30in	34in	37in	40in	43in	46in	49in	52in	55in	58in	61in	64in	67in
≤ 111in	96in	N/A	N/A	N/A	30in	34in	37in	40in	43in	46in	49in	52in	55in	58in	61in	64in	67in
≤ 120in	98in	N/A	N/A	N/A	N/A	34in	37in	40in	43in	46in	49in	52in	55in	58in	61in	64in	67in
≤ 129in	100in	N/A	N/A	N/A	N/A	N/A	37in	40in	43in	46in	49in	52in	55in	58in	61in	64in	67in
≤ 138in	102in	N/A	N/A	N/A	N/A	N/A	N/A	40in	43in	46in	49in	52in	55in	58in	61in	64in	67in
≤ 147in	104in	N/A	N/A	N/A	N/A	N/A	N/A	N/A	43in	46in	49in	52in	55in	58in	61in	64in	67in
≤ 156in	106in	N/A	N/A	N/A	N/A	N/A	N/A	N/A	N/A	46in	49in	52in	55in	58in	61in	64in	67in
≤ 165in	108in	N/A	N/A	N/A	N/A	N/A	N/A	N/A	N/A	N/A	49in	52in	55in	58in	61in	64in	67in
≤ 174in	110in	N/A	N/A	N/A	N/A	N/A	N/A	N/A	N/A	N/A	N/A	52in	55in	58in	61in	64in	67in
≤ 183in	112in	N/A	N/A	N/A	N/A	N/A	N/A	N/A	N/A	N/A	N/A	N/A	55in	58in	61in	64in	67in
≤ 192in	114in	N/A	N/A	N/A	N/A	N/A	N/A	N/A	N/A	N/A	N/A	N/A	N/A	58in	61in	64in	67in
≤ 201in	116in	N/A	N/A	N/A	N/A	N/A	N/A	N/A	N/A	N/A	N/A	N/A	N/A	N/A	61in	64in	67in
≤ 210in	118in	N/A	N/A	N/A	N/A	N/A	N/A	N/A	N/A	N/A	N/A	N/A	N/A	N/A	N/A	64in	67in
≤ 219in	*120in	N/A	N/A	N/A	N/A	N/A	N/A	N/A	N/A	N/A	N/A	N/A	N/A	N/A	N/A	N/A	67in

***Minimum Sensor Height - 90in (7ft 6in) *Maximum Sensor Height - 120in (10ft)**

3 Sensors - Metric (cm)																	
Threshold Width	Min Sensor Height	Sensor Heights															
		228cm	234cm	239cm	245cm	249cm	254cm	259cm	264cm	269cm	274cm	279cm	284cm	289cm	295cm	300cm	305cm
		Distance Between Sensors															
≤ 213cm	228cm	56cm	63cm	71cm	76cm	86cm	94cm	101cm	109cm	117cm	124cm	132cm	140cm	147cm	155cm	162cm	170cm
≤ 236cm	234cm	N/A	63cm	71cm	76cm	86cm	94cm	101cm	109cm	117cm	124cm	132cm	140cm	147cm	155cm	162cm	170cm
≤ 259cm	239cm	N/A	N/A	71cm	76cm	86cm	94cm	101cm	109cm	117cm	124cm	132cm	140cm	147cm	155cm	162cm	170cm
≤ 282cm	245cm	N/A	N/A	N/A	76cm	86cm	94cm	101cm	109cm	117cm	124cm	132cm	140cm	147cm	155cm	162cm	170cm
≤ 304cm	249cm	N/A	N/A	N/A	N/A	86cm	94cm	101cm	109cm	117cm	124cm	132cm	140cm	147cm	155cm	162cm	170cm
≤ 328cm	254cm	N/A	N/A	N/A	N/A	N/A	94cm	101cm	109cm	117cm	124cm	132cm	140cm	147cm	155cm	162cm	170cm
≤ 350cm	259cm	N/A	N/A	N/A	N/A	N/A	N/A	101cm	109cm	117cm	124cm	132cm	140cm	147cm	155cm	162cm	170cm
≤ 373cm	264cm	N/A	N/A	N/A	N/A	N/A	N/A	N/A	109cm	117cm	124cm	132cm	140cm	147cm	155cm	162cm	170cm
≤ 396cm	269cm	N/A	N/A	N/A	N/A	N/A	N/A	N/A	N/A	117cm	124cm	132cm	140cm	147cm	155cm	162cm	170cm
≤ 419cm	274cm	N/A	N/A	N/A	N/A	N/A	N/A	N/A	N/A	N/A	124cm	132cm	140cm	147cm	155cm	162cm	170cm
≤ 442cm	279cm	N/A	N/A	N/A	N/A	N/A	N/A	N/A	N/A	N/A	N/A	132cm	140cm	147cm	155cm	162cm	170cm
≤ 465cm	284cm	N/A	N/A	N/A	N/A	N/A	N/A	N/A	N/A	N/A	N/A	N/A	140cm	147cm	155cm	162cm	170cm
≤ 488cm	289cm	N/A	N/A	N/A	N/A	N/A	N/A	N/A	N/A	N/A	N/A	N/A	N/A	147cm	155cm	162cm	170cm
≤ 510cm	295cm	N/A	N/A	N/A	N/A	N/A	N/A	N/A	N/A	N/A	N/A	N/A	N/A	N/A	155cm	162cm	170cm
≤ 533cm	300cm	N/A	N/A	N/A	N/A	N/A	N/A	N/A	N/A	N/A	N/A	N/A	N/A	N/A	N/A	162cm	170cm
≤ 556cm	*305cm	N/A	N/A	N/A	N/A	N/A	N/A	N/A	N/A	N/A	N/A	N/A	N/A	N/A	N/A	N/A	170cm

***Minimum Sensor Height - 228cm (2.28m) *Maximum Sensor Height - 305cm (3.05m)**



Standard Wall Mount

The Standard Wall Mount is used for mounting the sensor to various wall types using the provided multi-surface wall anchors and screws.

Refer to section 7 for more details and mounting instructions.



Ceiling Mount

The Ceiling Mount is used for mounting the sensor to the ceiling in front of the entryway. The kit includes two options:

- + A Toggle Anchor for hollow ceiling types like drywall or ceiling tiles
- + A Threaded Rod Anchor for wood and steel, and Expansion Anchors for various solid surface materials like wood, metal, tile, stone & plaster.

Refer to sections 8 and 9 for more details and mounting instructions.



Door Frame Mount (Top and Bottom)

The Door Frame Mount is used for mounting the sensor to the top or bottom surface of a wood or metal door frame.

Refer to sections 10 and 11 for more details and mounting instructions.

Wall Mount

07



Wall Mount Kit (Included, available for order)

- + Wall Bracket
- + 2pcs #8 x 1.25in Rounded Head Screws
- + 2pcs Multi-Surface Anchors
- + Hex Key



Materials NOT included

- + Drill
- + Mallet or Hammer
- + Level
- + Measuring tape
- + Pencil
- + 3/16in drill bit
- + Ethernet Cable (Cat 5e or later)

Power & connectivity

All sensors require power over ethernet and internet connectivity.

Mounting with Screws and Anchors

The Wall Mount Kit comes with 2pcs #8 x 1.25" Phillips Rounded Head Screws and 2pcs Multi-Surface Toggler Anchors designed for a wide range of materials (concrete, brick, stone, drywall, etc.). The anchor expands and elongates within a solid substrate to distribute force evenly. For hollow substrates, the anchor jaws pop open to lock into position.

Anchors should be used for all wall materials except for wood. For wood, use the screws and drill directly into the surface.

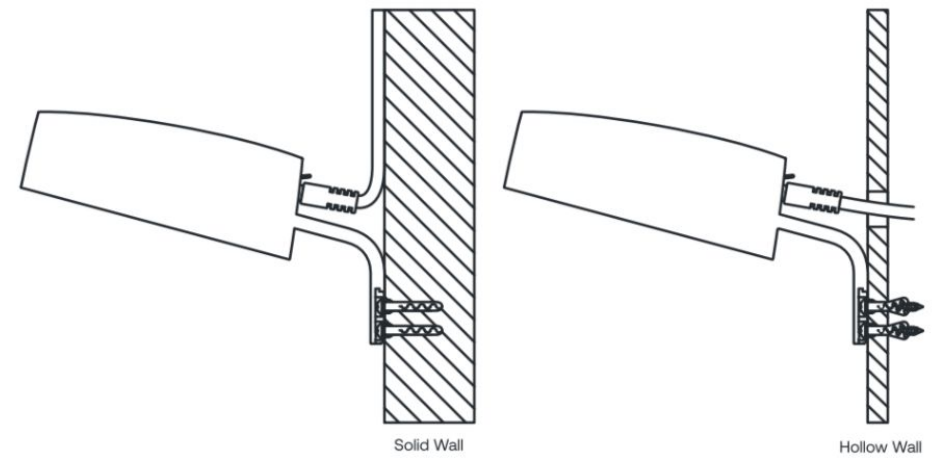
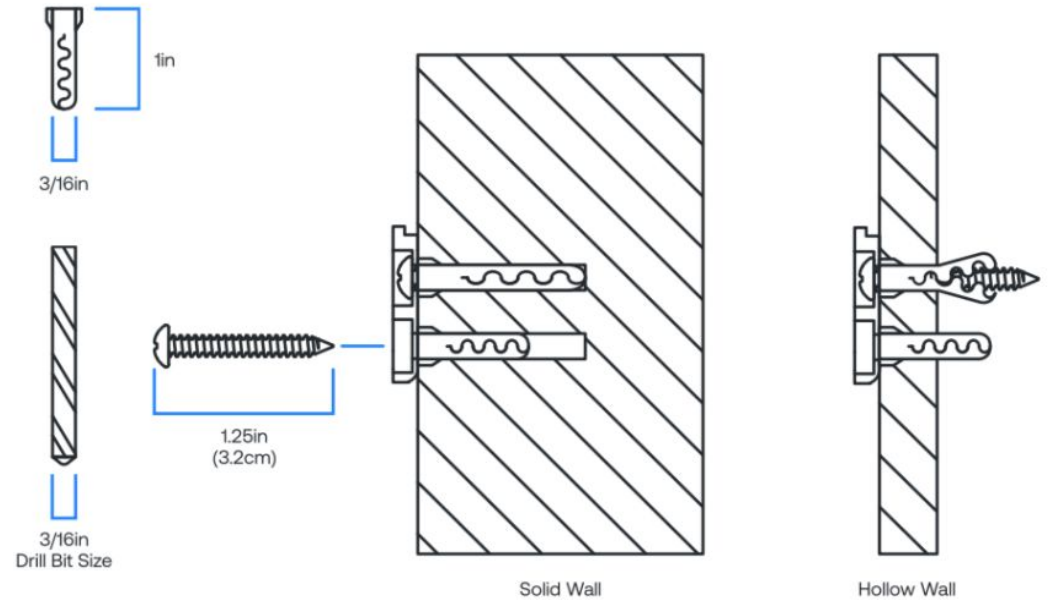

Cable Management - Hidden

For hollow wall installs, the cable can be hidden by drilling a hole into the wall material and threading the ethernet cable through the drilled hole.

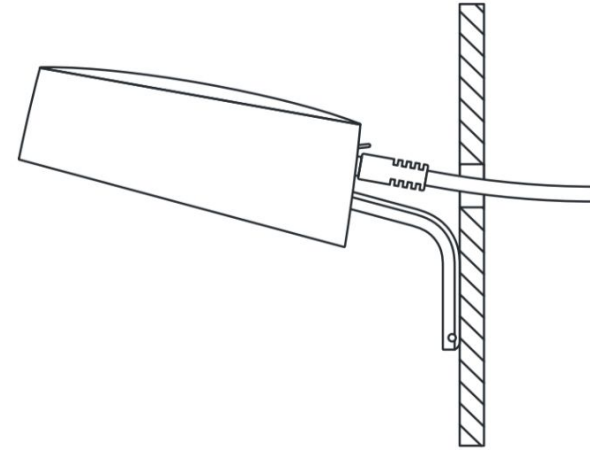

Cable Management - Exposed

For solid and hollow wall installs, the cable can be secured directly to the wall surface using cable clip fasteners or channeling.

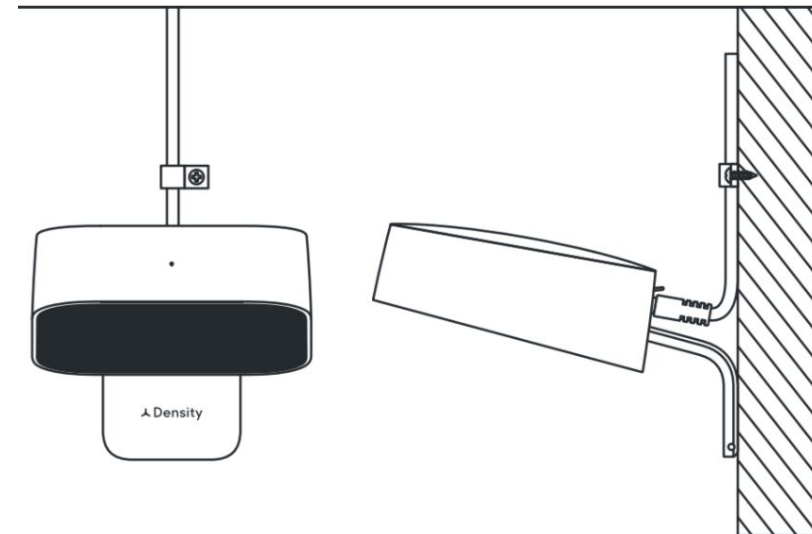

Step 1: Prepare The Sensor

Remove the protective film on the back of the sensor. Use the provided Hex Key to release the Wall Bracket from the Mount Arm.

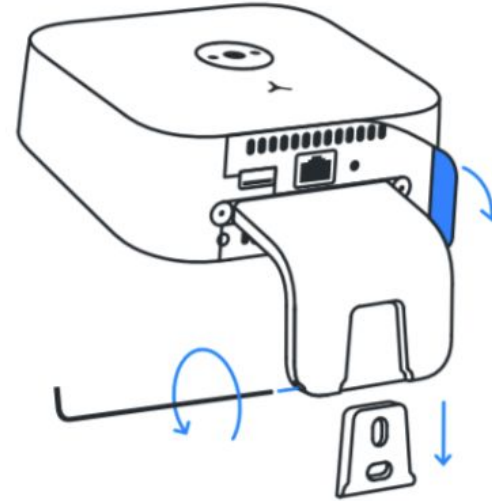

Step 2: Mark Placement

Before installing, refer to and follow the supported mounting height and clearance requirements in section 5.

Center the Wall Bracket horizontally above the doorway. Use the level to ensure the Wall Bracket is parallel to the ground. Use a pencil to mark the center of the two holes in the Wall Bracket.

If any objects obstruct the sensor, you may install the sensor slightly off-center or consider moving the obstruction. Please consult your Density Account Manager before offsetting the sensor.

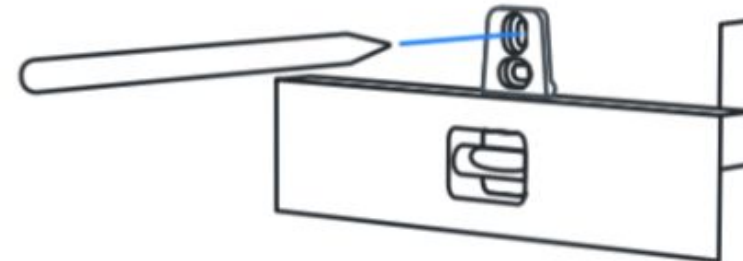

Step 3: Drill Holes

Drill a hole through each pencil mark using a 3/16 in drill bit. For hollow substrates, drill completely through. For solid wall materials, drill holes with a depth of at least 1 1/4 in (3.2 cm).

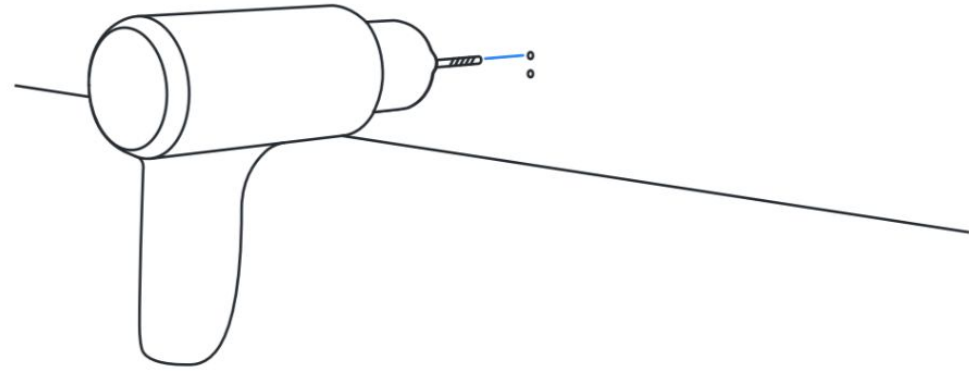

Step 4: Insert Anchors

Use a mallet or hammer to tap the anchors into each hole. Anchors should be flush with the wall.

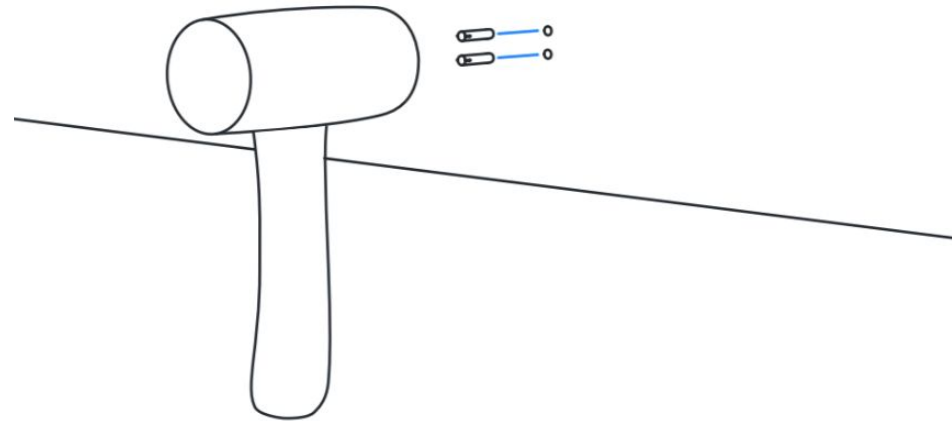

Step 5: Install Wall Bracket

Align the holes in the Wall Bracket with the installed anchors. Use a drill with #2 Phillips Screwdriver Bit or a standard Phillips head screwdriver to drive each screw into the drywall anchors.

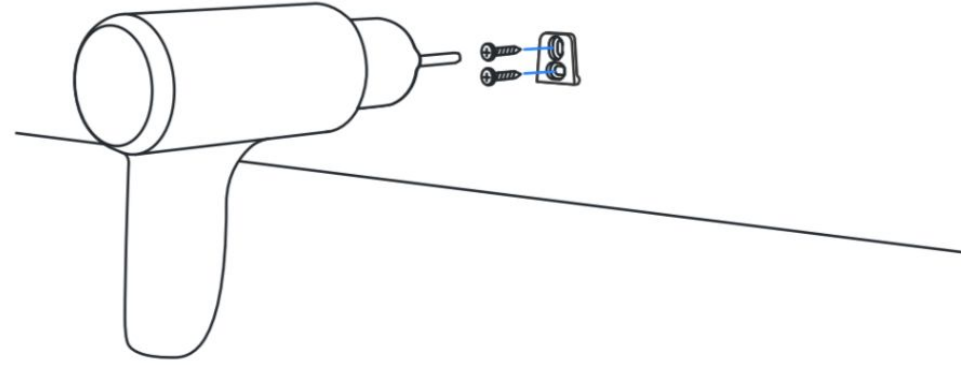

Step 6: Power Up The Sensor

Plug in the ethernet cable. The sensor will automatically power up, and the LED indicator on the front of the sensor will turn white or blue.

See the networking section for troubleshooting information if you see any other colors on the LED indicator.

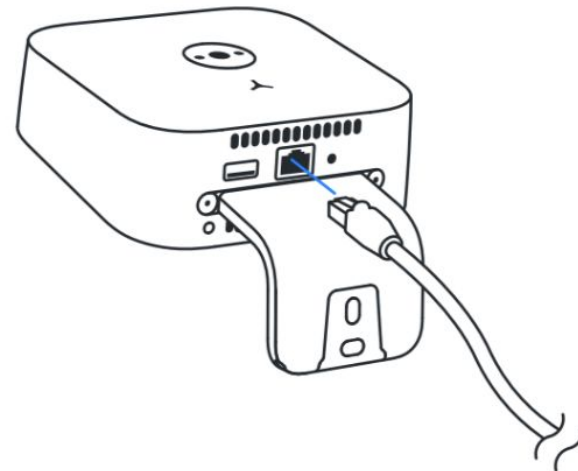

Step 7: Wall Mount

Slide the sensor downward onto the installed Wall Bracket.

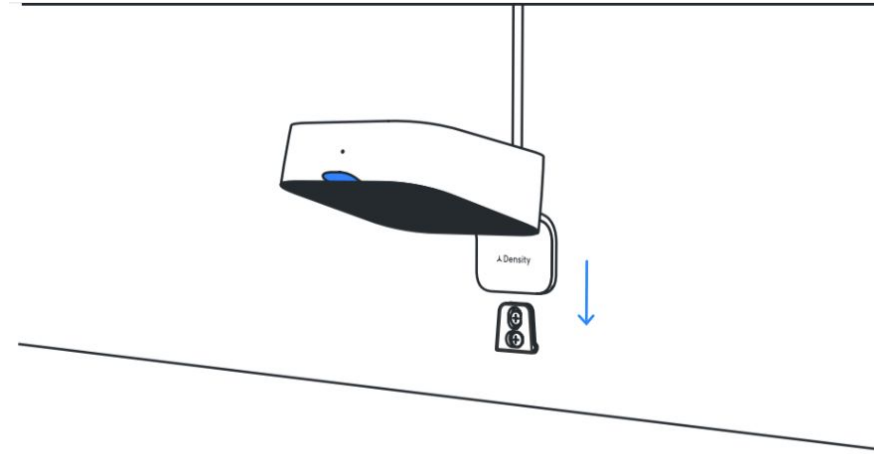

Step 8: Lock Sensor and Peel Film

Lock the sensor to the Wall Bracket with the provided Hex Key by twisting the set screw all the way in. Remove the protective film on the black window.

Ensure the black sensor window remains free of dust and smudges during operation. Wipe with a microfiber cloth to remove any accidental smudges.

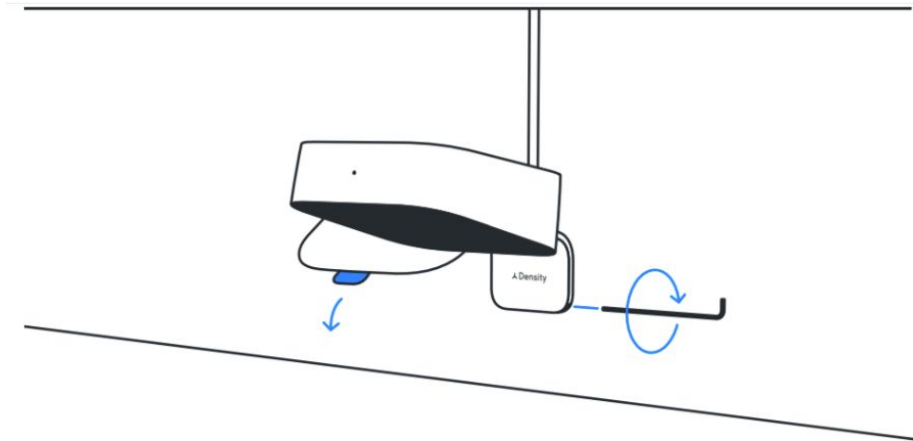

Ceiling Mount - Toggle Anchor

For hollow ceiling types



08

Ceiling Mount Kit (available for order)

- + 1/4in-20 Toggle Anchor
- + Steel Washer
- + Hex Nut
- + Hex Key



Materials NOT included

- + Measuring tape
- + Drill
- + Wrench or Pliers
- + 5/8in Drill Bit
- + 1/4in-20 Threaded rod (5in minimum length)
- + Ethernet Cable (Cat 5e or later)

Power & connectivity

All sensors require power over ethernet and internet connectivity.

Toggle anchor

Designed for hollow ceiling types (drywall, plaster, ceiling tiles, wood paneling, etc.), the Toggle Anchor has spring-loaded wings that fold flush and then re-open once they have passed through the ceiling material.

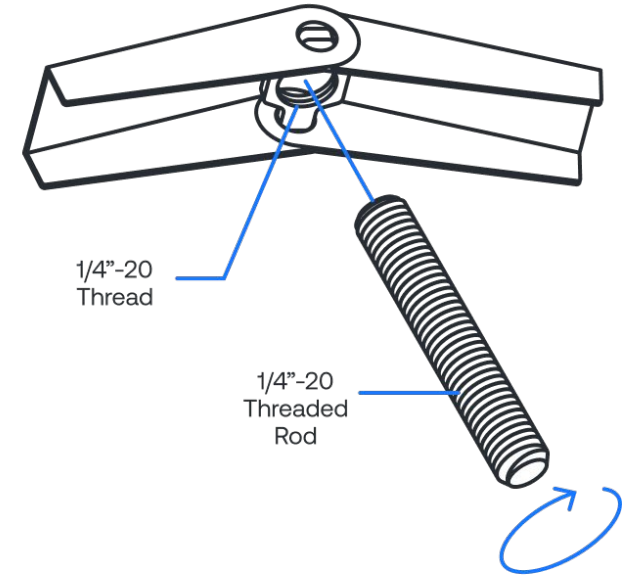
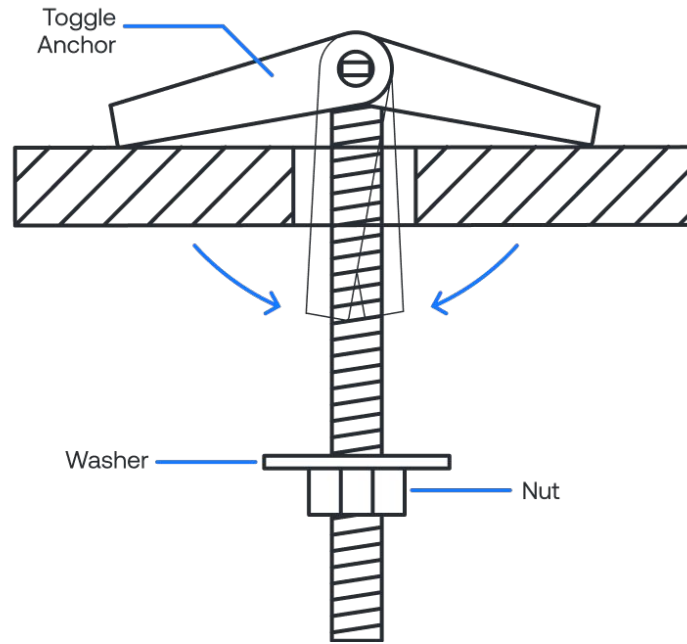

Step 1: Prepare The Sensor

Remove the protective film on the back of the sensor. Use the provided Hex Key to unscrew the two flat head screws and release the Mount Arm.

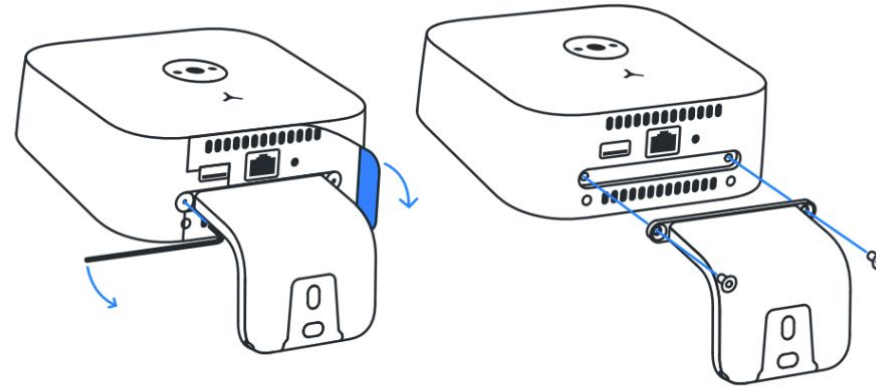

Step 2: Insert Rubber Plug

The sensor comes with a Rubber Plug (located in the Wall Mount Kit Box) designed to cosmetically cover the cavity where the Mount Arm was. Insert the plug by pressing the two pegs firmly into the two holes in the mount cavity. A small arrow on the inner surface of the Rubber Plug indicates which direction should face upward.

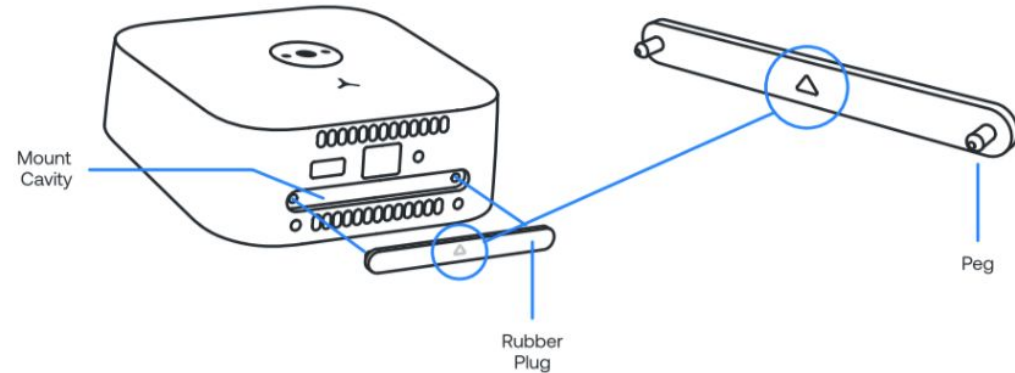

Step 3: Drill Mounting Hole

Before installing, refer to and follow the supported mounting height and clearance requirements in section 5.

Mark a spot 3.5 in (8.9 cm) away from the wall centered horizontally above the entryway. Drill a hole all the way through the hollow ceiling material using the 5/8 in drill bit.

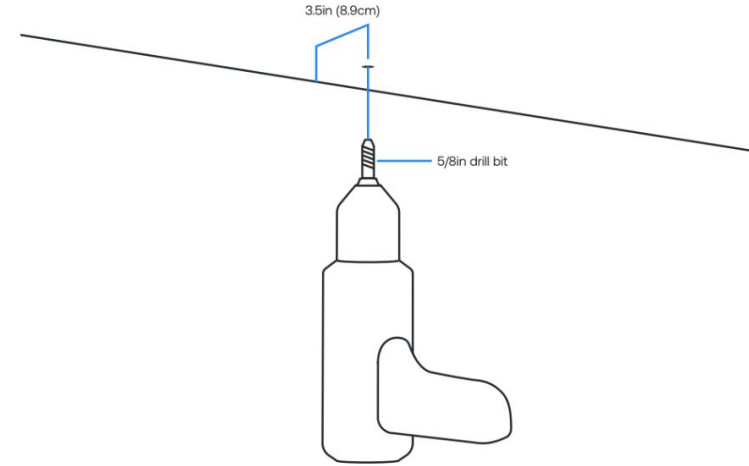

Step 4: Assemble

Screw the sensor onto the bottom end of the threaded rod. Ensure that the threaded rod is screwed completely into the threads on the sensor. Screw the nut and washer onto the top end of the threaded rod. Screw the Toggle Anchor onto the top end of the threaded rod. Make sure that the threaded rod is fully threaded into the Toggle Anchor.

The 1/4 in -20 threads on the sensor have an internal nylon washer designed to prevent the sensor from coming off the threaded rod. The nylon washer requires firm initial pressure to engage the threads of the rod. If needed, use a pair of pliers to clamp onto the threaded rod for a firm grip while threading on the sensor.

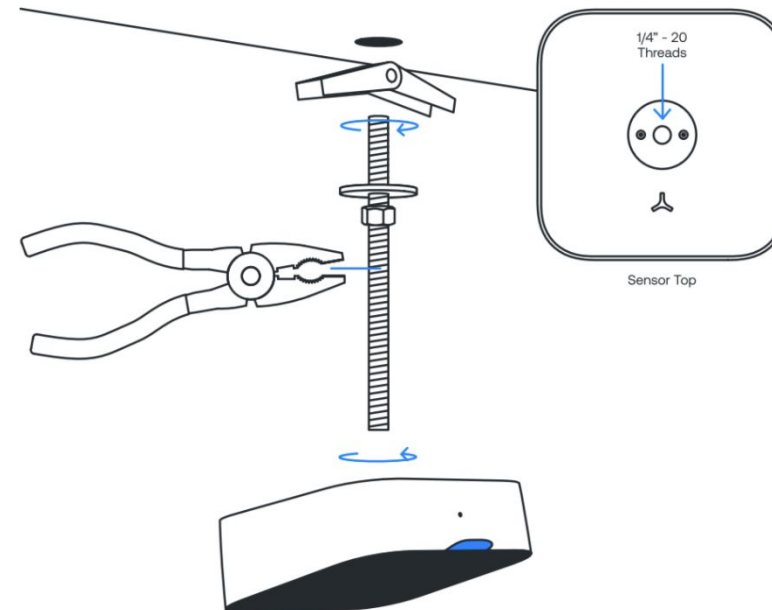

Step 5: Insert Toggle Anchor Into Ceiling

Fold the Toggle Anchor flaps down, then insert the Toggle Anchor and end of the threaded rod through the drilled hole. Once through the ceiling, the Toggle Anchor flaps will spring open again.

To adjust the install height, twist the threaded rod counterclockwise to raise or clockwise to lower (with a recommended clearance of at least 3 in between the top of the unit and the ceiling). Make sure the threaded rod has enough thread engagement with the Toggle Anchor.

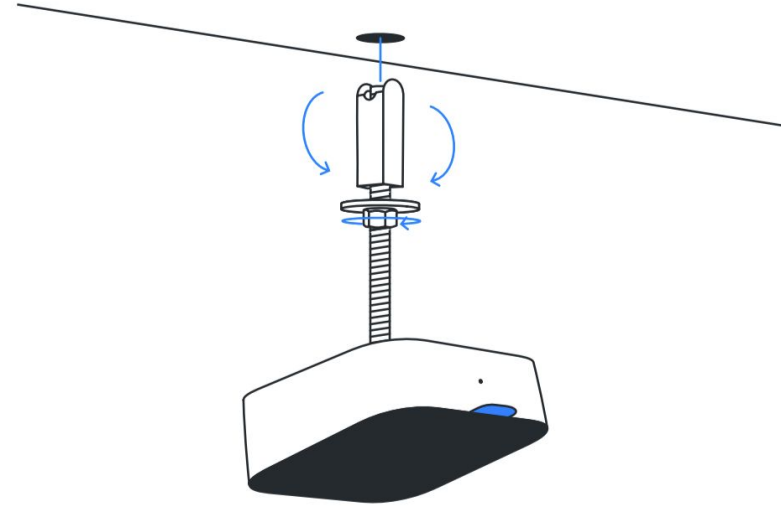

Step 6: Tighten the Anchor Assembly

Once desired install height is determined, twist the nut and washer until they are tight against the ceiling. Tighten the nut with a wrench or pliers so that the washer provides strong clamping pressure against the ceiling.

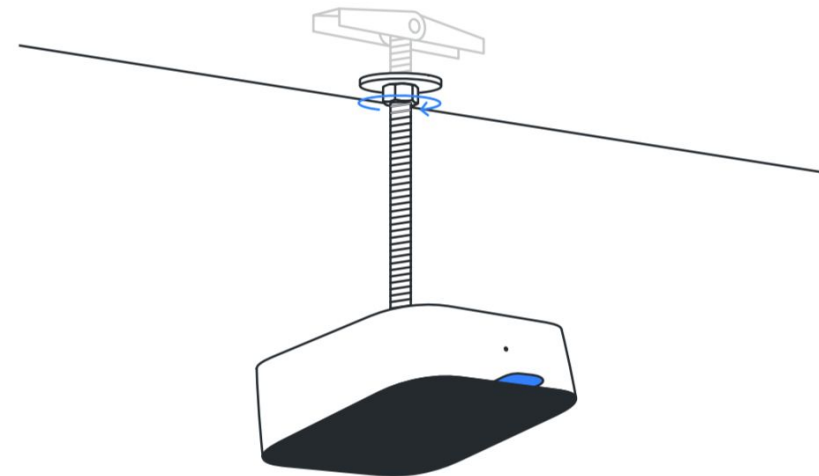

Step 7: Power Up The Sensor

Plug in the ethernet cable. The sensor will automatically power up, and the LED indicator on the front of the sensor will turn white or blue.

See the networking section for troubleshooting information if you see any other colors on the LED indicator.

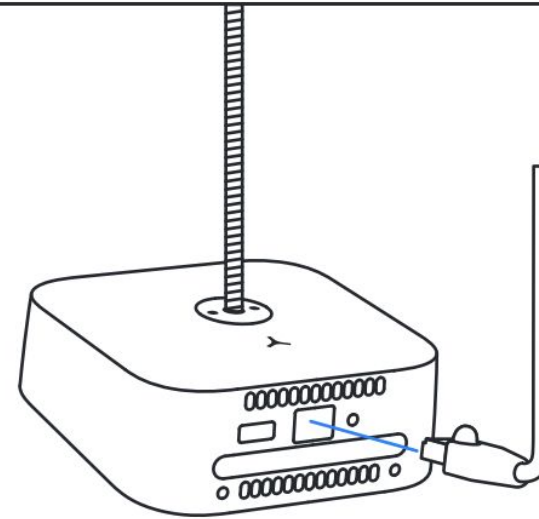

Step 8: Secure Cable

A zip tie can be used to secure the ethernet cable to the threaded rod for tidy cable management.

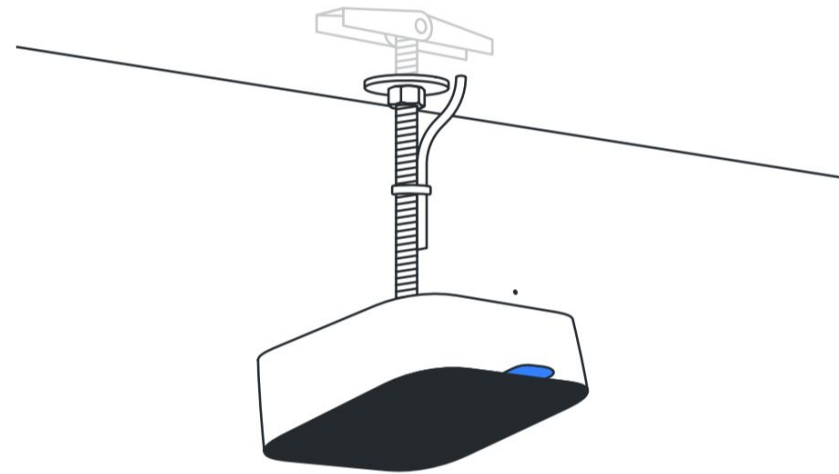

Step 9: Peel Film

Remove the protective film on the black window.

Ensure the black sensor window remains free of dust and smudges during operation. Wipe with a microfiber cloth to remove any accidental smudges.

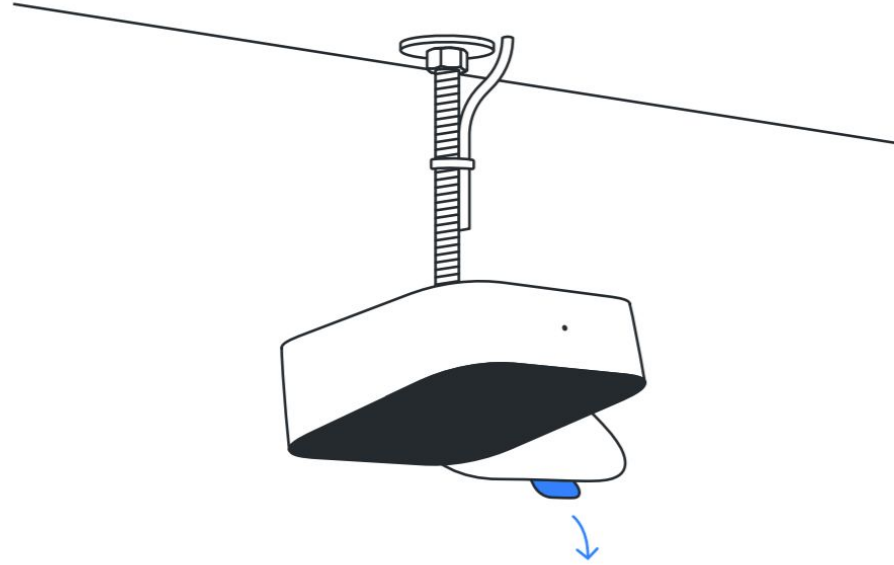

Cable Management

A 1/2 in PVC pipe can be used to run the cable and rod through. Before assembly, cut the PVC pipe to the proper length and drill or cut a notch or hole at the top of the pipe to allow for cable relief. For optimal cable aesthetics, we recommend using a flat white Cat 5e or greater ethernet cable, as shown. Make sure to use a pipe size with a minimum inner diameter of 0.62 in (1.6 cm).

Note: Please be careful when bending the cable to avoid cable failure.

Minimum Pipe
Size

0.84in
(2.1cm)

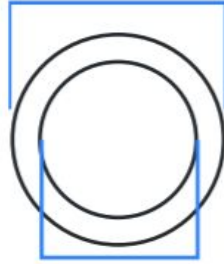

0.62in
(1.6cm)

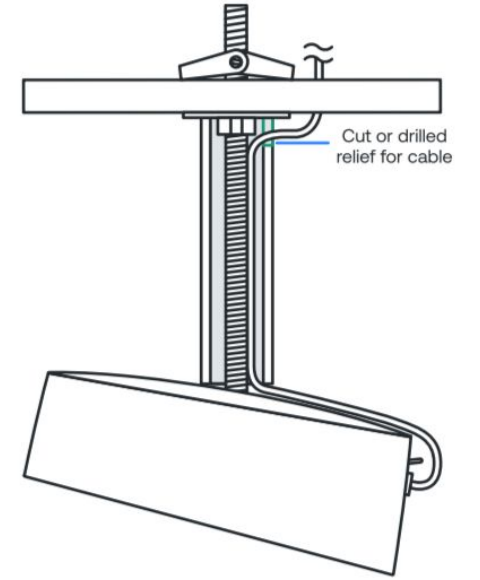
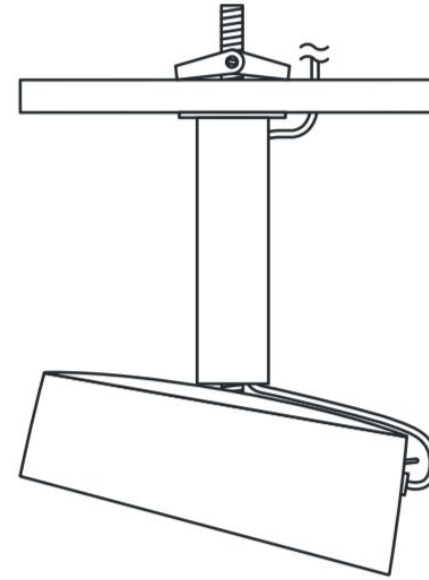

Sensor Height

The illustration below indicates the minimum recommended distance from the ceiling to the internal sensor for when the device is mounted as flush to the ceiling as possible.

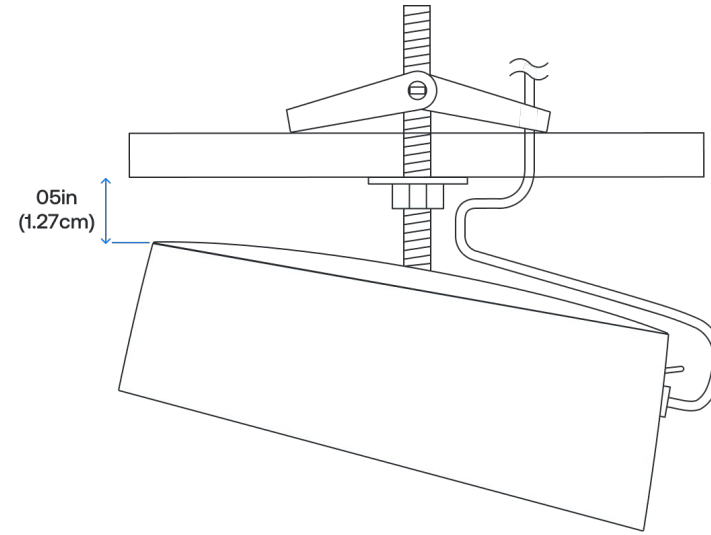

Ceiling Mounting - Threaded Anchor

For solid ceiling types



09

Ceiling Mount Kit (available for order)

- + Hex Key
- + Threaded Rod Anchor - Wood
- + Threaded Rod Anchor - Steel
- + Expansions Anchor - Concrete
- + Installation Tool - Concrete



Materials NOT included

- + Measuring tape
- + Drill
- + 5/8in Drive Socket - Wood only
- + 1/2in Drive Socket - Steel only
- + ANSI 3/8" masonry bit - Concrete only
- + 1/4in-20 Threaded rod
- + Ethernet Cable (Cat 5e or later)

Power & connectivity

All sensors require power over ethernet and internet connectivity.

Threaded Rod Anchor

Install directly into a mounting surface to suspend a threaded rod. The Ceiling Mount Kit ships with three different mounting anchors designed for wood, steel, and concrete surfaces. The wood and steel anchors require a drill along with the appropriate sized drive socket (not included) for installation. The concrete anchor requires a hole drilled by an ANSI 3/8" masonry bit, as well as a hammer (not included) and an installation tool (included).

Wood Anchor

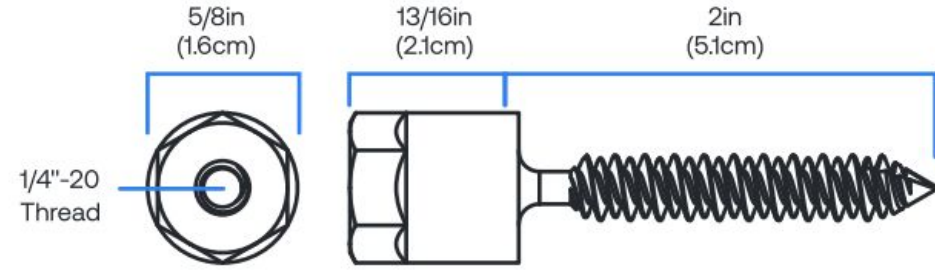

Steel Anchor

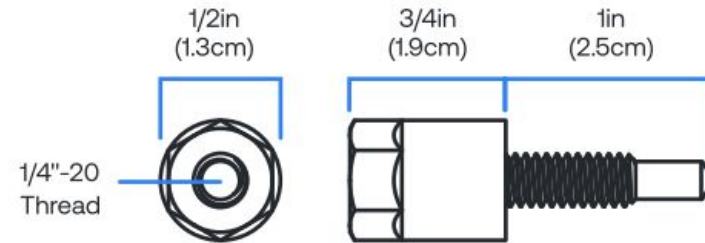

Concrete Anchor

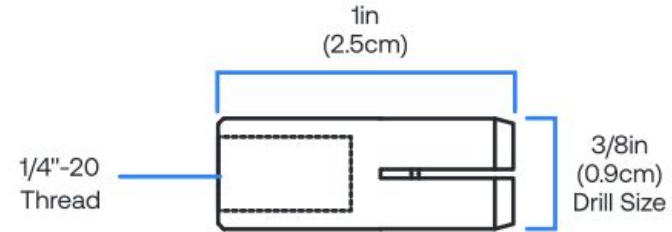

Step 1: Prepare The Sensor

Remove the protective film on the back of the sensor. Use the provided Hex Key to unscrew the two flat head screws and release the Mount Arm.

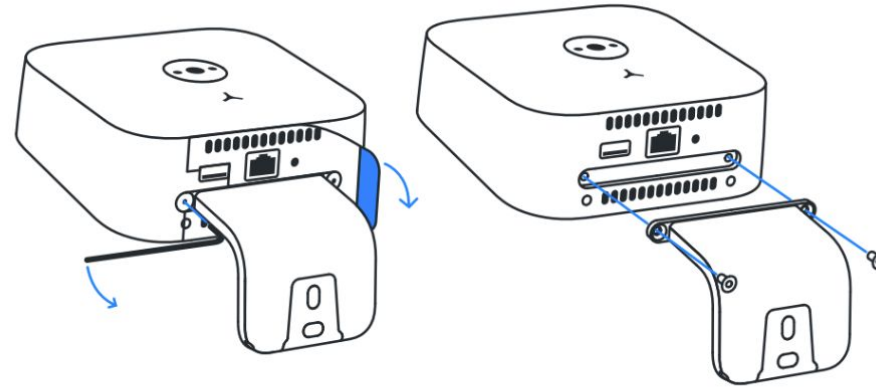

Step 2: Insert Rubber Plug

The sensor comes with a Rubber Plug (located in the Wall Mount Kit Box) designed to cosmetically cover the cavity where the Mount Arm was. Insert the plug by pressing the two pegs firmly into the two holes in the mount cavity. A small arrow on the inner surface of the Rubber Plug indicates which direction should face upward.

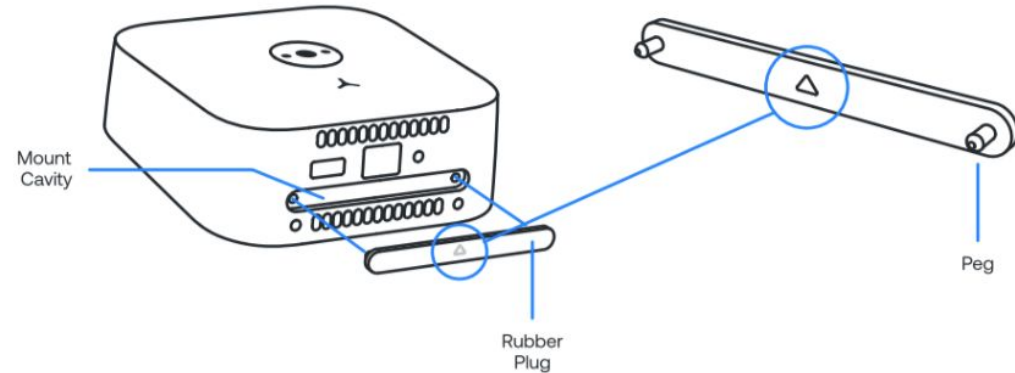

Step 3: Install Ceiling Anchor

Before installing, refer to and follow the supported mounting height and clearance requirements in section 5.

Mark a spot 3.5in (8.9cm) away from the wall that is centered horizontally above the entryway.

Wood and Steel installation: Use a drill and a drive socket (5/8in for wood, 1/2in for steel) to drive the anchor into the ceiling until the bottom side of the anchor head is flush with the ceiling.

Concrete installation: Anchors for concrete require a hole drilled by an ANSI 3/8in masonry bit. To install, place the anchor into the drilled hole, insert the required installation tool into the anchor, and drive with a hammer until the thicker portion of the tool makes contact with the anchor. When installed, anchors sit flush with the surface.

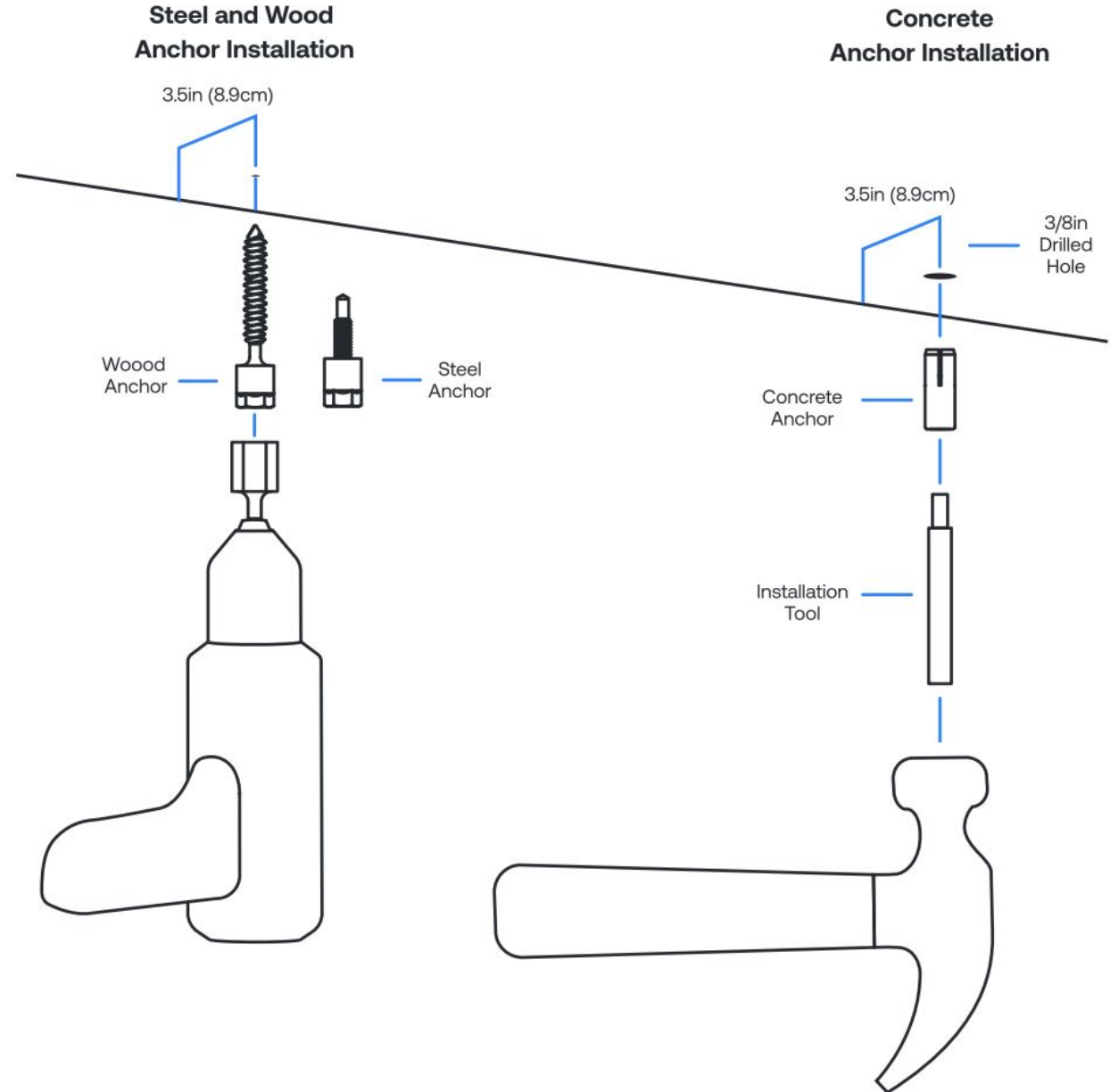

Step 4: Assemble

Screw the sensor onto the bottom end of the threaded rod. Twist the threaded rod completely into the threads of the Anchor. Make sure that the threaded rod is threaded completely into both the sensor and the Anchor.

The 1/4"-20 threads on the sensor have an internal nylon washer which is designed to prevent the sensor from coming off the threaded rod. The nylon washer requires firm initial pressure to engage the threads of the rod.

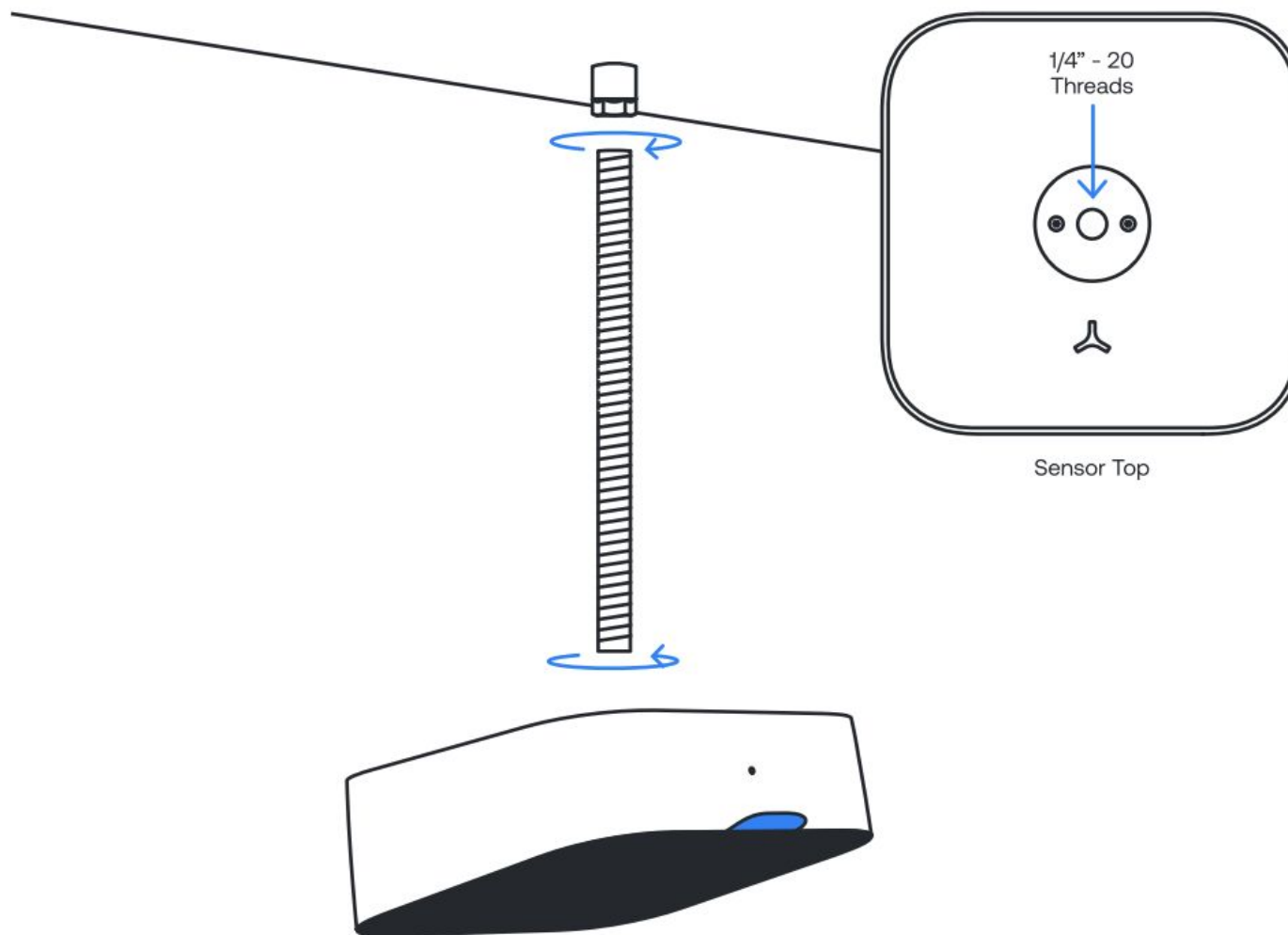

Step 7: Power Up The Sensor

Plug in the ethernet cable. The sensor will automatically power up, and the LED indicator on the front of the sensor will turn white or blue.

See the networking section for troubleshooting information if you see any other colors on the LED indicator.

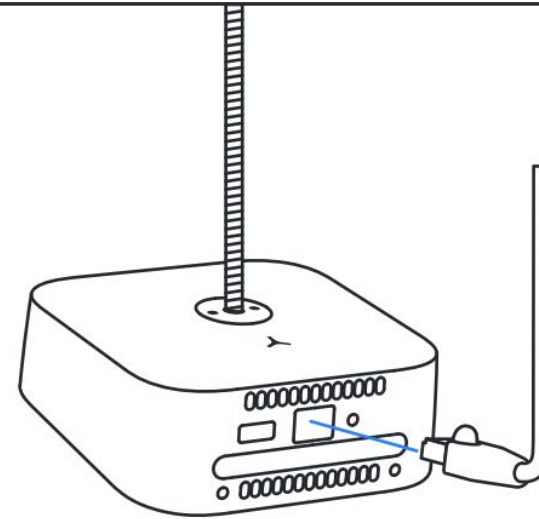

Step 8: Secure Cable

A zip tie can be used to secure the ethernet cable to the threaded rod for tidy cable management.

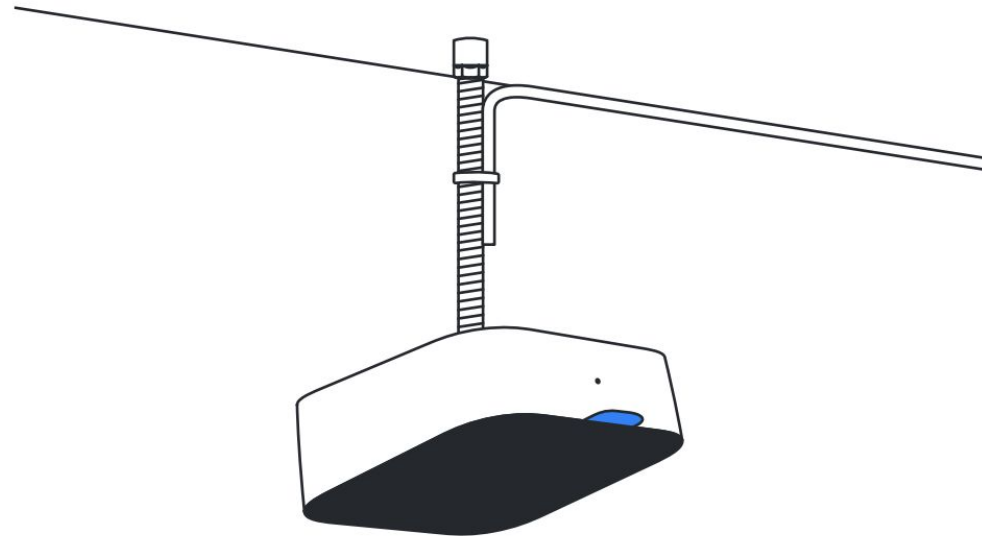

Step 9: Peel Film

Remove the protective film on the black window.

Ensure the black sensor window remains free of dust and smudges during operation. Wipe with a microfiber cloth to remove any accidental smudges.

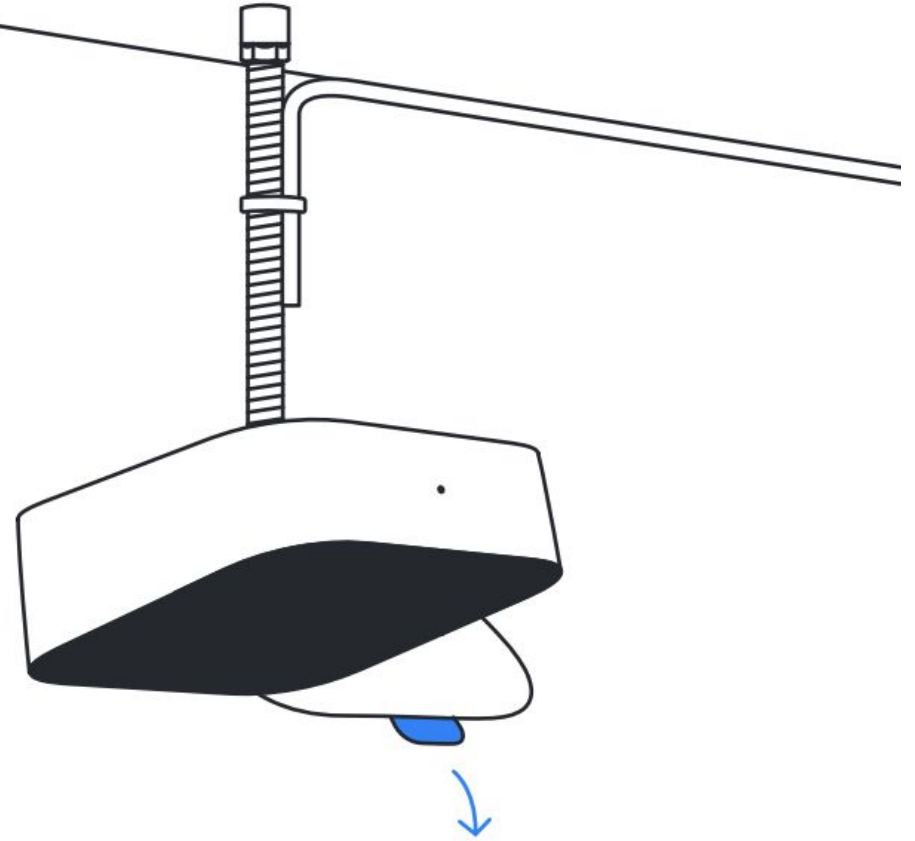

Cable Management

A .5 in PVC pipe can be used to run the cable and rod through. Before assembly, cut the PVC pipe to the proper length and drill or cut a notch or hole at the top of the pipe to allow for cable relief. For optimal cable aesthetics, we recommend using a flat white Cat 5e or greater ethernet cable as shown. Make sure to use a pipe size with a minimum inner diameter of 0.62 in (1.6cm).

Minimum Pipe
Size

0.84in
(2.1cm)

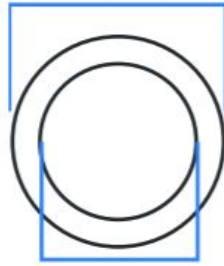

0.62in
(1.6cm)

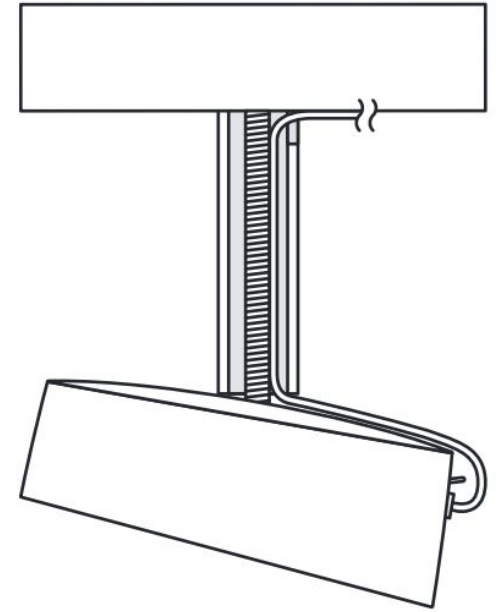
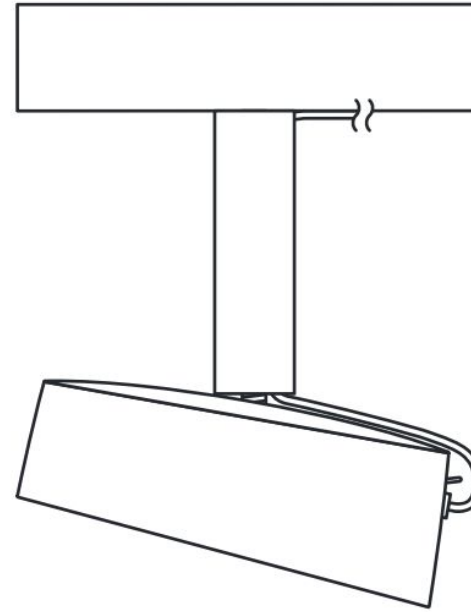

Sensor Height

The illustration below indicates the standard recommended distance from the ceiling to the internal sensor for when the device is mounted as flush to the ceiling as possible.

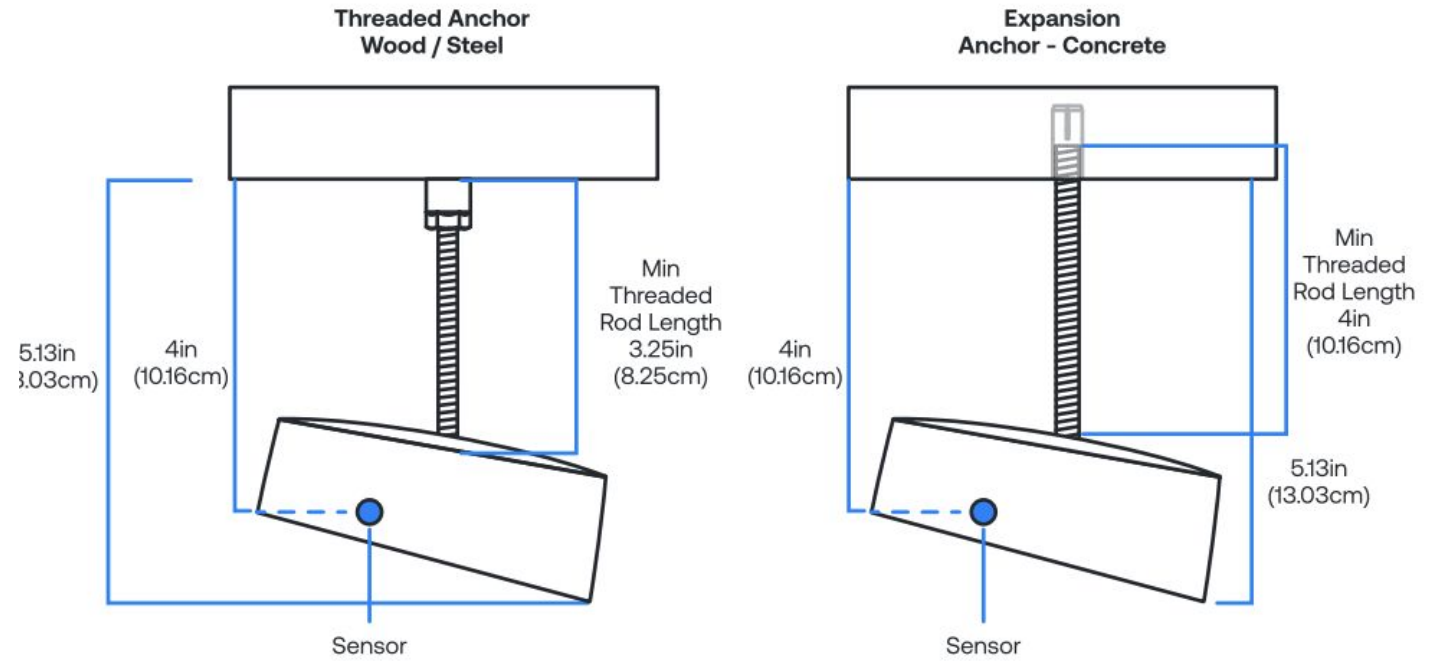

Top of Frame Mount

10



Door Frame Mount Kit (available for order)

- + Utility Mount
- + Hex Key
- + 2pcs Self-Drilling Screws, #6 x 1.5in



Materials NOT included

- + Drill
- + #2 Phillips Screwdriver Bit
- + Ethernet Cable (Cat 5e or later)

Power & connectivity

All sensors require power over ethernet and internet connectivity.

Step 1: Screw In Utility Mount

Before installing, refer to and follow the supported mounting height and clearance requirements in section 5.

Center the Utility Mount horizontally above the entryway and 1/4 in (0.6 cm) away from the front edge of the frame, as shown. Use a drill to drive both self-tapping screws through the Utility Mount and into the top of the door frame.

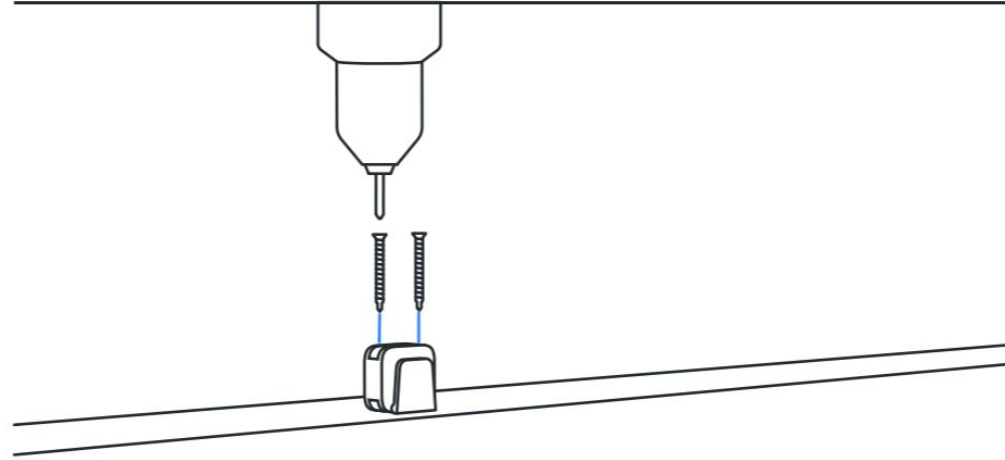

Step 2: Prepare The Sensor

Remove the protective film on the back of the sensor. Use the provided Hex Key to release the Wall Bracket from the Mount Arm.

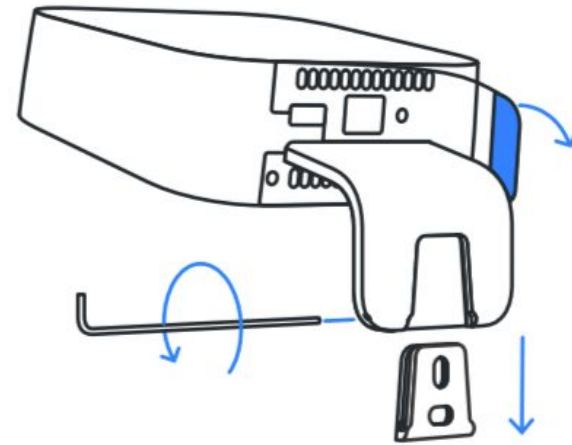

Step 3: Power Up The Sensor

Plug in the ethernet cable. The sensor will automatically power up, and the LED indicator on the front of the sensor will turn white or blue.

See the networking section for troubleshooting information if you see any other colors on the LED indicator.

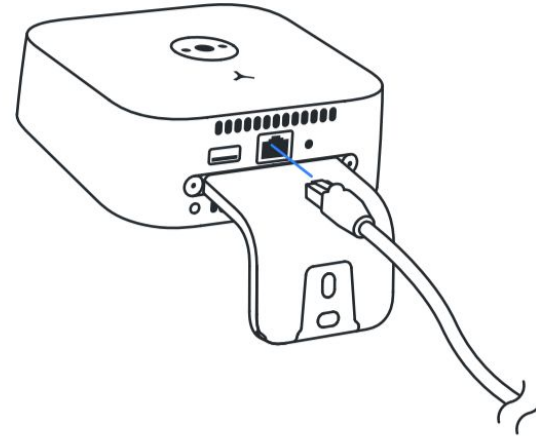

Step 4: Mount the Sensor

Slide the sensor downward onto the Utility Mount.

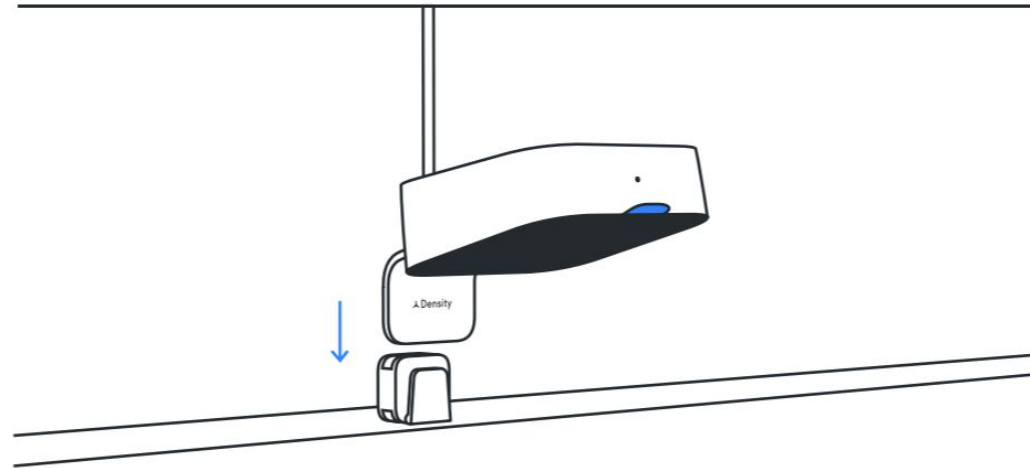

Step 5: Lock Sensor

Lock the sensor to the Utility Mount with the provided hex key by twisting the set screw all the way in.

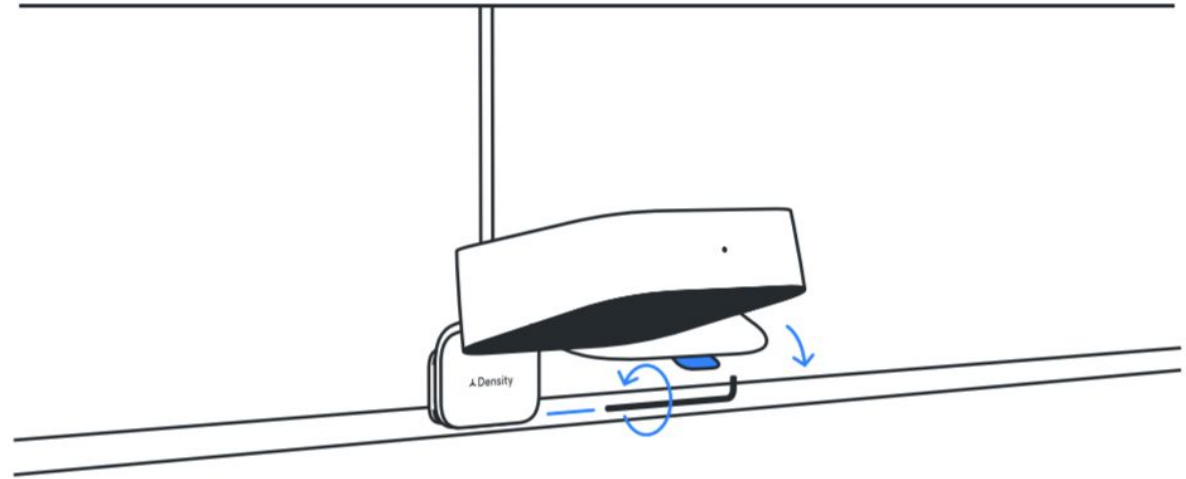

Step 6: Peel Film

Remove the protective film on the black window.

Ensure the black sensor window remains free of dust and smudges during operation. Wipe with a microfiber cloth to remove any accidental smudges.

Bottom of Frame Mount

11



Door Frame Mount Kit (available for order)

- + Utility Mount
- + Hex Key
- + 2pcs Self-Drilling Screws, #6 x 1.5in



Materials NOT included

- + Drill
- + #2 Phillips Screwdriver Bit
- + Ethernet Cable (Cat 5e or later)

Power & connectivity

All sensors require power over ethernet and internet connectivity.

Cable Management

For tidier cable management, the ethernet cable can be run within the hollow frame.

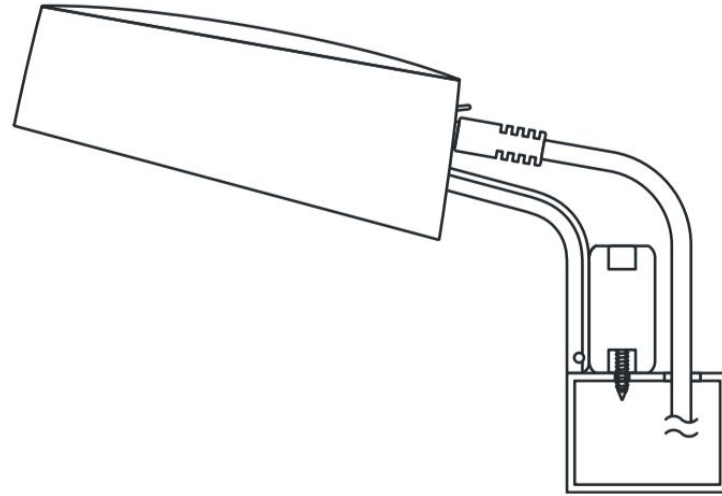

Step 1: Screw In the Door Frame Mount

Before installing, refer to and follow the supported mounting height and clearance requirements in section 5.

Center the Utility Mount horizontally above the entryway and 0.27 in (0.68 cm) away from the front edge of the frame, as shown. Use a drill to drive both self-tapping screws through the Utility Mount and into the bottom of the door frame.

Note the orientation of the Door Frame Mount.

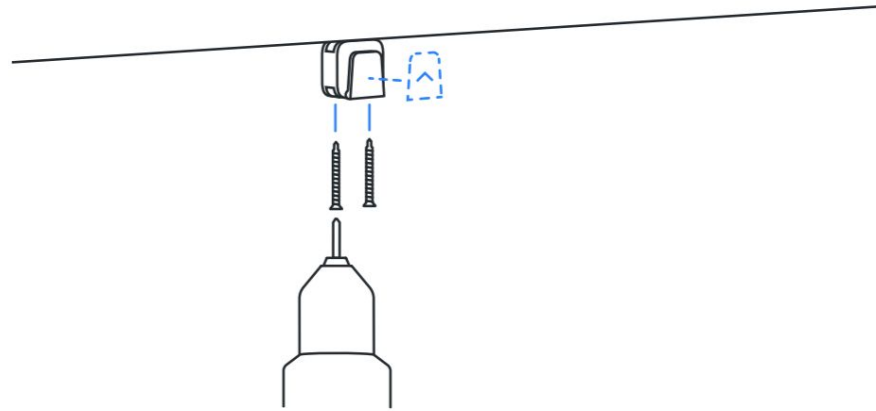

Step 2: Prepare The Sensor

Remove the protective film on the back of the sensor. Use the provided Hex Key to release the Wall Bracket from the Mount Arm.

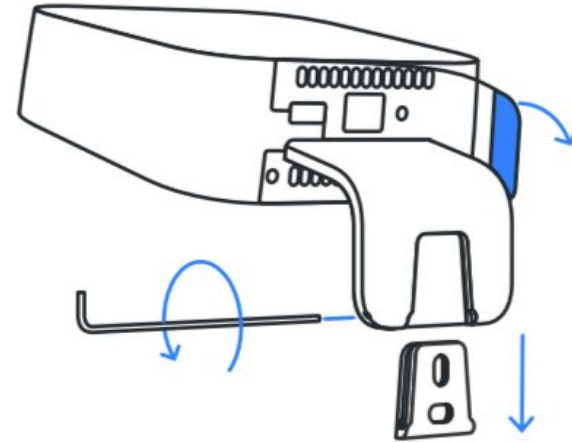

Step 3: Power Up The Sensor

Plug in the ethernet cable. The sensor will automatically power up, and the LED indicator on the front of the sensor will turn white or blue.

See the networking section for troubleshooting information if you see any other colors on the LED indicator.

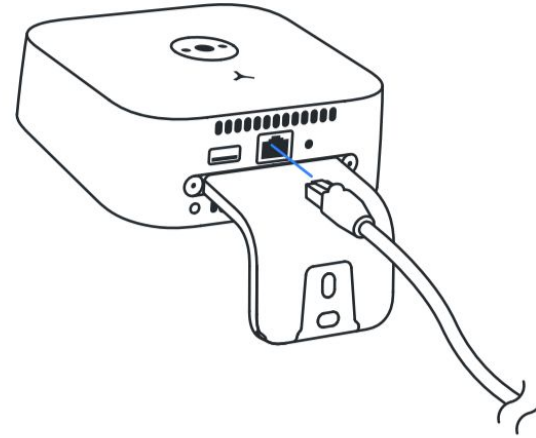

Step 4: Mount the Sensor

Slide the sensor downward onto the Utility Mount.

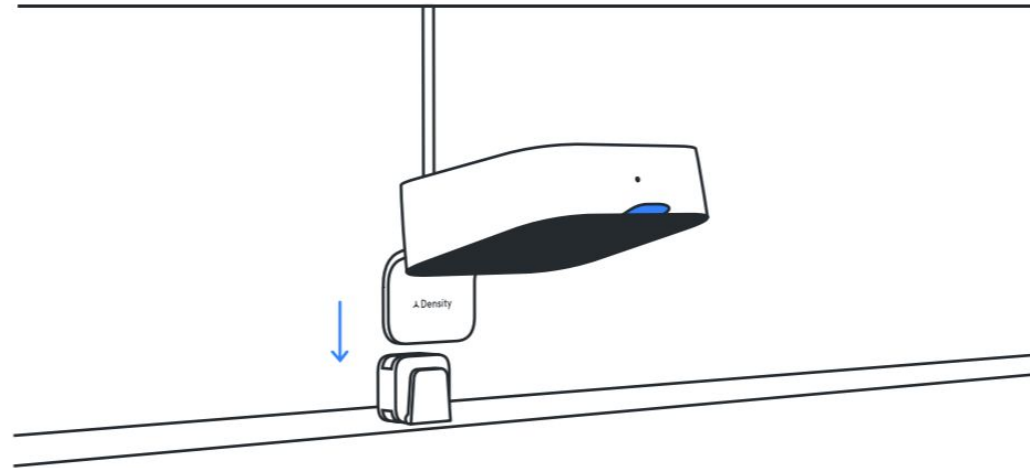

Step 5: Lock Sensor

Lock the sensor to the Utility Mount with the provided hex key by twisting the set screw all the way in.

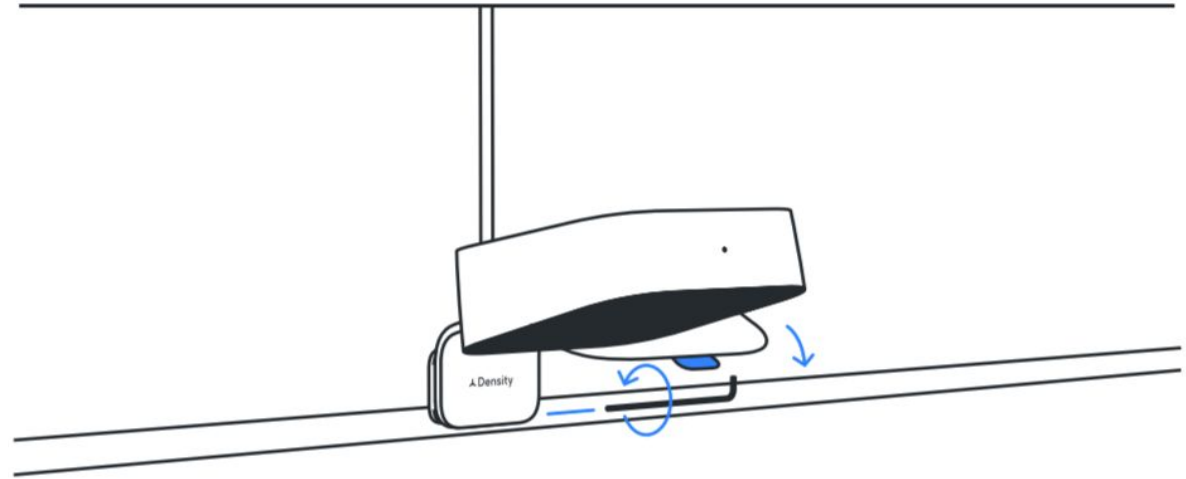

Step 6: Peel Film

Remove the protective film on the black window.

Ensure the black sensor window remains free of dust and smudges during operation. Wipe with a microfiber cloth to remove any accidental smudges.