

Complete Installation Guide

Waffle Sensor



Product

- + Density Waffle sensor
- + USB-C cable and wall adapter (US only)
- + QR code for Quick Start Guide
- + QR code for Legal information booklet

Wall mount kit

- + Mount plate
- + Two screws
- + Two adhesive strips
- + Hex key

Not included:

- + Anchors
- + Cable management

QR Code to Setup App

- + To successfully complete the installation process for this sensor, you will need an Apple device (iPhone or iPad) with WiFi/Bluetooth connectivity

Sensors

Single-chip 57-61GHz mmWave sensor

Environmental specifications

- + Temperature: 32° - 95°F (0° - 35°C)
- + Relative humidity: 20% to 80% non-condensing
- + Rated for indoor installation only

Interface

- + WiFi/Bluetooth
- + Reset Button

Indicators

Multi-color status LED

Unit weight

0.132lbs (60g)

MAC address

Full list included with shipment, and by request at support@density.io

Serial Number Label & Serial QR Code

Appears behind the mount plate of the Waffle sensor

Dimensions & features

- + Full plastic body (molded PC-ABS)
- + Three set-ups: Wall Mount (standard with adhesive tape, or screws)
- + Separate Accessories: stand and under mount

Interface

- + WiFi/Bluetooth
- + Reset button

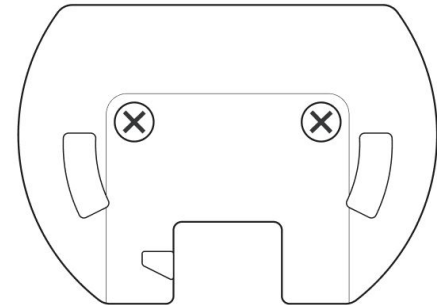
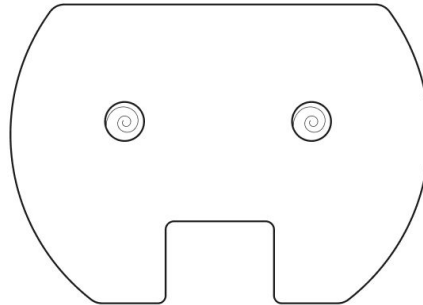
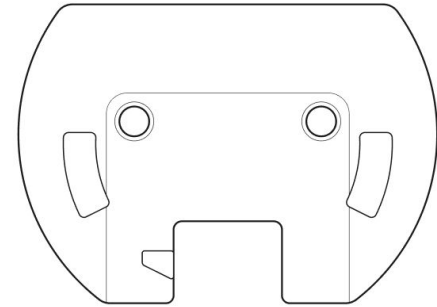
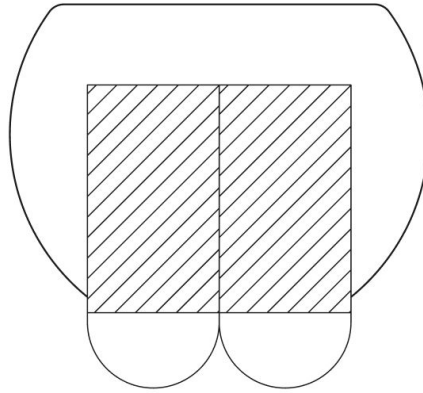
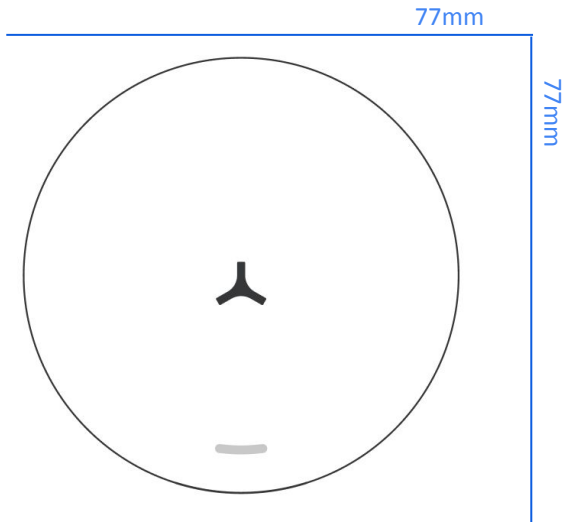

Resetting the sensor

To reset the sensor to default factory settings, press and hold the reset button for 11 seconds. The LED will turn red and then blue, indicating you can now set up your device in the setup app. The sensor must be plugged in and connected to power in order to reset.



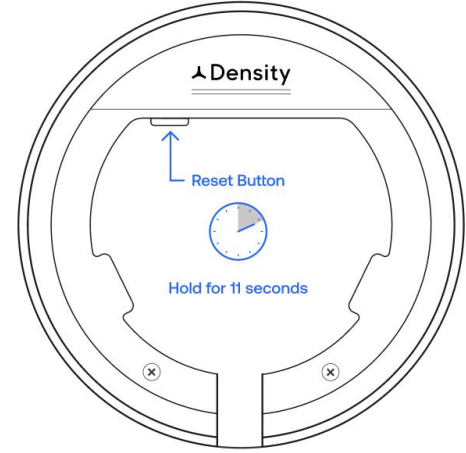
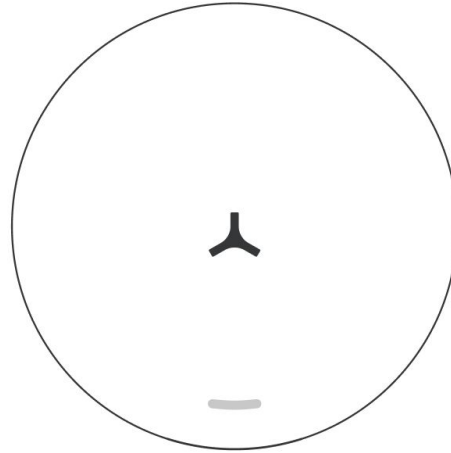





Holding the button for 11 seconds will factory reset your sensor, and you will need to set up your device in the app again. It will not be connected to your space until you complete the setup. You will not lose historical data.



Sensor LED status indicator

The sensor has an indicator LED located on the front of the sensor. The color chart below explains the meaning of each color, defines any issues, and lists what actions to take if necessary.

If the recommended action does not resolve the LED light error status, factory reset the sensor. To reset, press and hold the reset button on the bottom of the sensor until the LED light starts flashing white. If the issue persists, please reach out to support@density.io

Color	Visual	Meaning	Description/Action
No Light		No Power	Error Check the cable and outlet works, move the sensor to a known working outlet (ensure the device LED brightness is not set at 0)
White		Operating Normally	No action needed
White blink		Locate/Boot	No action needed FYI: - on device start, the led blink until all the firmware is fully started - on customer LOCATE command, waffle blink during 60s
Blue		Ready to be Provisioned	Bluetooth is active and ready for set up. Use setup app to configure your device (assign your device to org and space)
Blue blink		Bluetooth communication in progress	No action needed FYI: LED blinks all the time the setup app is connected to the sensor
Purple		No Density Server	Error The Density server is not available. Check that no firewall is blocking these addresses
Purple blink		No DNS	Error DNS servers are not reachable. The sensor has an IP address but cannot resolve domain names. Check that all allowlisting is complete, including MAC address if required. Reapply the internet connection through the app.
Red		Internet Issue	Error Certain WiFi networks are not supported: captive portal, proxy, WPA2 enterprise, hidden networks Check that all allowlisting is complete, including MAC address if required. Reapply the internet connection through the app. Confirm the WiFi network you are trying to connect to has access to the internet. Test this by connecting your phone to the same network.

Power requirements

Waffle is powered by a AC power adaptor and requires 5v.

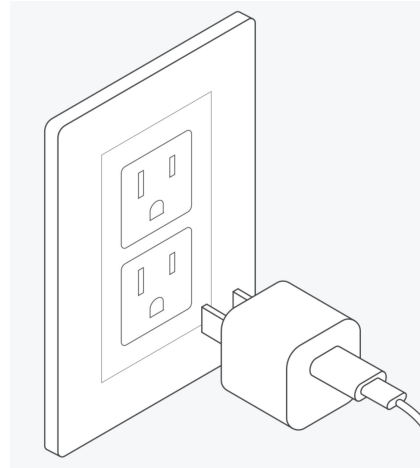

Cable requirements

Waffle utilizes USB-C. A 6 foot long USB-C to USB-C cable is included.

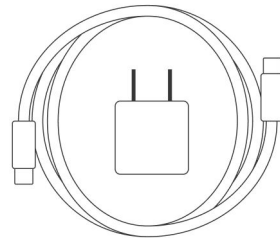

Networking basics

Density devices require internet connectivity via WiFi to pass data to the web application (requires the Density Unit Setup App to locally set up the device).

Networks that are not supported:

- + Captive portal
- + Proxy
- + WPA2 Enterprise
- + Hidden Networks *

** Hidden networks can be used if temporarily made transparent while we configure the devices.*

If you have a corporate firewall

You will need to whitelist the device MAC addresses (the MAC addresses can be found on the outside of the packaging box for the device). You will also need to whitelist the following addresses to ensure the device is able to communicate to your corporate network:

*.density.io
*.s3.amazonaws.com
*.pool.ntp.org (required for static IP)
connman.net
connectivitycheck.gstatic.com
8.8.8.8 (if applicable)
8.8.4.4 (if applicable)

Density does not currently support IP address whitelisting. A list of exact API subdomains is available by request.

- + ntp port (port 123) must be open
- + If internal DNS is not available then external DNS servers 8.8.8.8 and 8.8.4.4 will be used and port 53 must be open

Density Spaces App

iOS application used to connect and configure Waffle devices. Available in the App Store and mobile.density.io.

Network configuration options

Both DHCP and Static IP configurations are supported.

DHCP supported configuration

Option 53 – DHCP Message Type

- + Discover

Option 57 – Maximum DHCP Message Size

- + 576

Option 55 – Parameter List

- + Subnet Mask (1)
- + Router (3)
- + Interface MTU (26)
- + Private/Proxy Auto Discovery (252)
- + Network Time Protocol Servers (42)
- + Domain Name (15)
- + Domain Name Server (6)
- + Hostname (12)

Option 60 – Vendor Class Identifier *

- + “Density S5 DPU”

Option 61 – Client Identifier

- + M Address

Option 12 – Hostname

- + Density-<Serial>

Static configuration requirements

You will need an IPv4 Address and Name Servers from your IT team to use in the setup process. (Requires the Density Unit Setup App to locally set up the device).

Before you begin

05

Device placement

Follow these general guidelines for optimal sensor location:

- **Power Requirement:** Waffle must be powered via USB-C. Look for a location with an available outlet. A 6-foot cable is included for U.S. customers.
- **Clear Field of View:** Ensure no objects are placed directly in front of the Waffle unit, as this will obstruct its field of view.
- **Proper Orientation:** The Waffle's LED and cable should always be positioned at the bottom.
- **Sensor Height:** The Waffle should be installed at a height between 3.5 feet and 5 feet. We recommend installing at least one foot above the top of the table or desk in the room.

Depending on your mounting method, please refer to the appropriate mounting section for additional guidelines.

Device Measurement

- + When measuring the install height of the Waffle, be sure to measure to the center of the mounting screw holes on the wall mount, or to the center of the Density logo on the device, depending on your mounting option.

Device interference

- + Avoid placing objects (eg: books, chairs, movable whiteboards, chairs) in front of the device. Anything between the unit and where people will be located blocks the Field of View and will impact accuracy. Objects within 2 feet of the front of the device are especially impactful.
- + Avoid moving the sensor once it has gone through zone setup. If the sensor is moved out of position, the data associated with the device would be incorrect and the sensor will need to be reconfigured through the Density App, or moved back to its original position.

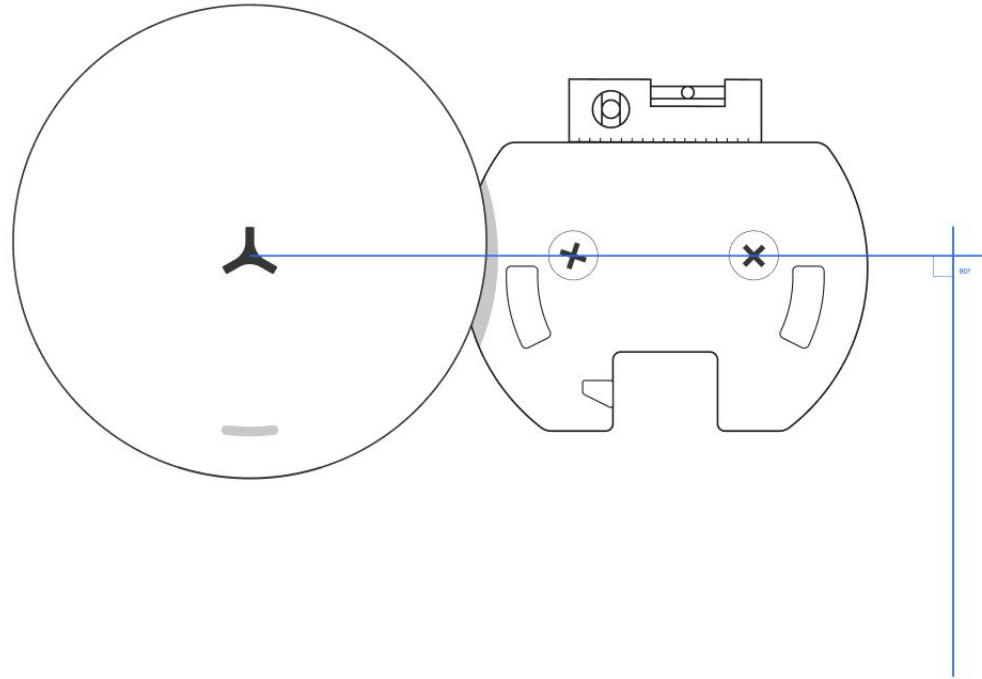

Wall mount

- + Mount plate
- + Two adhesive strips

Materials not included

- + Level
- + Optional cable management
- + Alcohol wipe
- + Microfiber cloth
- + Cable management

Power & connectivity

All sensors require USB-C (included)

Step 1: Remove mount plate

Remove device from box.

Turn the attached mount plate counter-clockwise to remove mount from sensor. The plate will twist off, do not pull until unlocked from magnets.

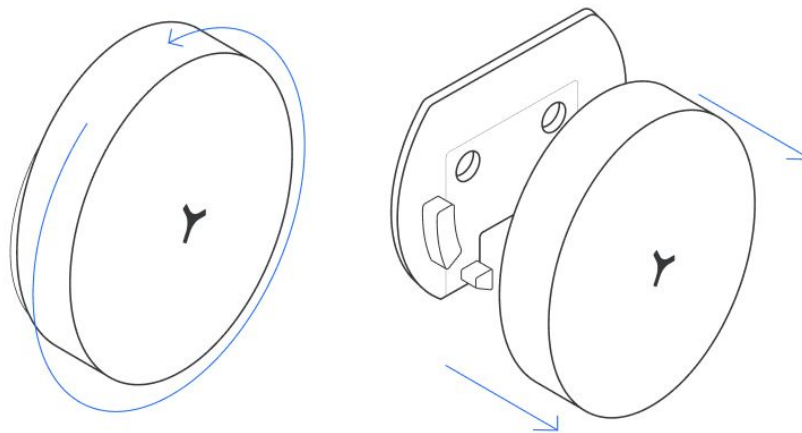

Step 2: Attach adhesive to mount

Separate and attach both adhesives **vertically** to the back of the sensor, so the removal pull tags hang in the opening for later removal. Press and hold firmly onto the mount for 15 seconds.

Note:

- Align the top of adhesive strip with the top edge of the cutout.
- Ensure wall side is facing out.

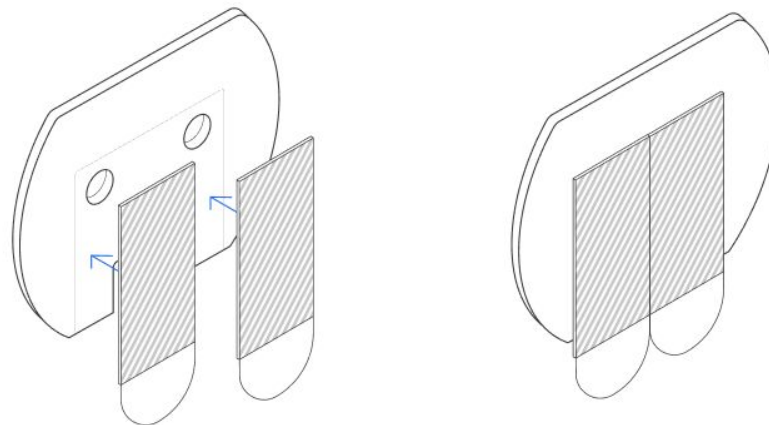

Step 3: Identify installation location

Follow these guidelines for optimal sensor location:

- + **Power Requirement:** The Waffle must be powered via USB-C. A 6-foot cable is included for U.S. customers.
- + **Clear Field of View:** Ensure no objects are placed directly in front of the Waffle unit, as this will obstruct its field of view.
- + **Proper Orientation:** The Waffle's LED and cable should always be positioned at the bottom.
- + **Sensor Height:** The Waffle should be installed at a height between 42"-60". We recommend being at least 12" above the top of the table or desk in the room.
- + **Sensor Location on Wall:** The Waffle should be installed as close to the center of the wall as possible. Do not install near corners.

Step 4: Secure adhesive

Remove the wall side liner and attach to wall.
Press and hold the adhesive for 15 seconds.

Note: Do not attach your Waffle device to the mount yet.

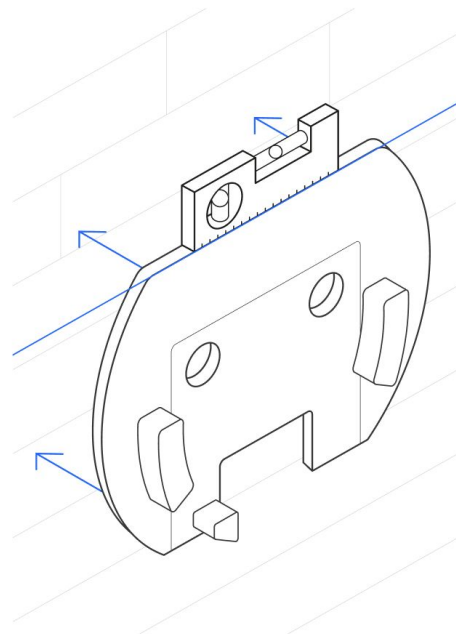
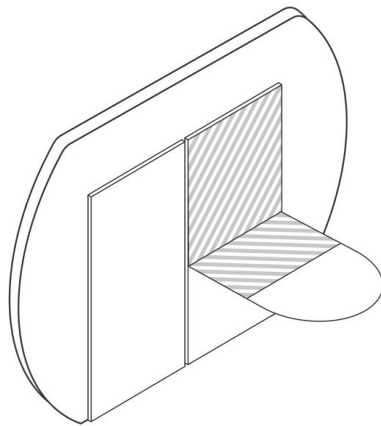

Step 5: Identify the sensor in the Density Spaces app

Download the Density Spaces app in the App Store (iOS only) or via mobile.density.io.

Before placing the Waffle back onto the mount plate, open the app, and scan the QR code on the back of the sensor.

If you've already placed the sensor on the mount plate, use the QR code on the back of the box or manually enter this Waffle's serial number.

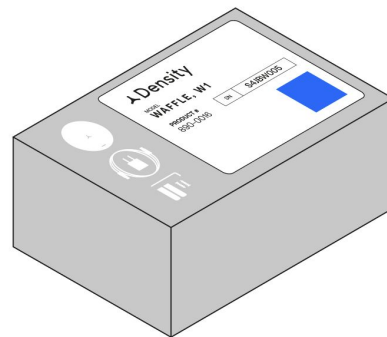
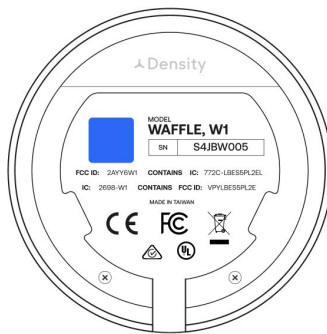

Step 6: Insert USB-C

Insert the USB-C into the Waffle device until you hear a click.

Optional: Insert USB-C locking clip

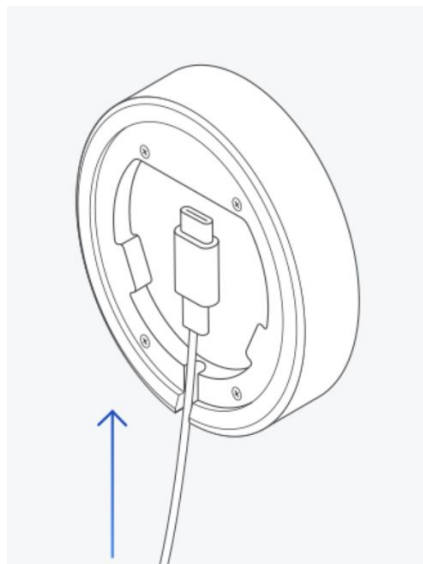

Step 7: Attach Waffle to mount

Hold the waffle at 10 o'clock position and when you feel the magnets activate, twist clockwise to lock into mount.

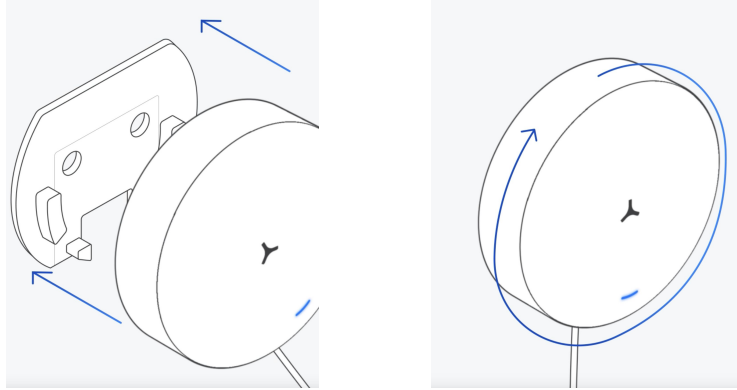

Step 8: Plug in sensor

Plug in the wall adapter to the cable and power supply. The LED light will turn blue to show it receiving power, and is ready to begin provisioning in the setup app.

Please note: do not plug in the sensor until you are prompted to do so in the setup app. The bluetooth connection will time out at 5 minutes.

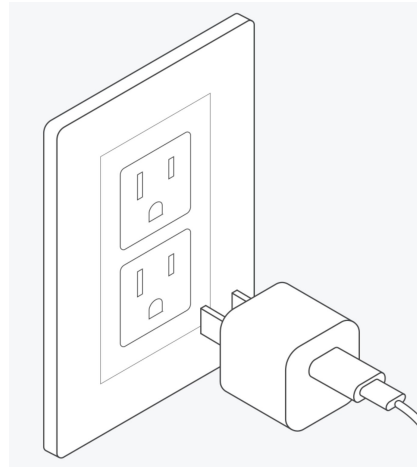

Step 9: Complete setup in the app

Follow the setup instructions in the Density Spaces app. The Density Spaces app is available in the Apple App Store, or at mobile.density.io.

If you have not completed WiFi setup within five minutes, Bluetooth will disconnect and the LED will turn from blue to red. Please unplug Waffle and plug it back in to reactivate Bluetooth. You'll see the LED turn blue.

When the LED turns white, you have successfully set up your Waffle.

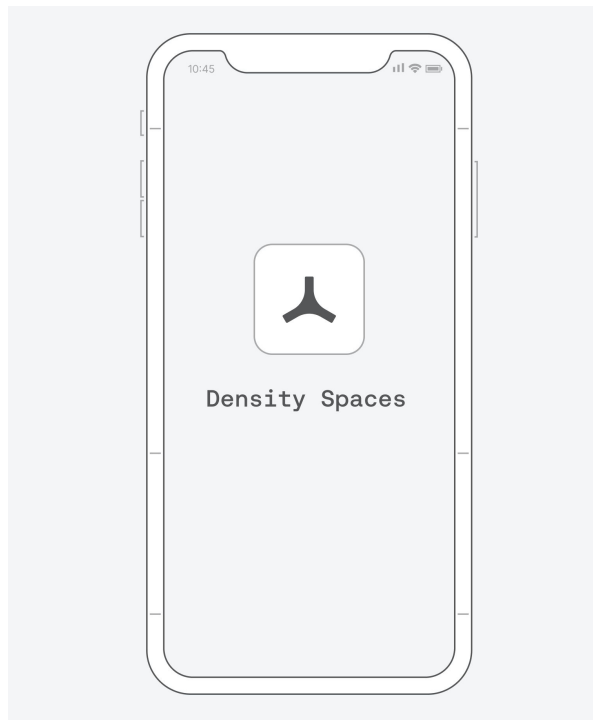

Optional: Tighten the locking screw

Place the provided hex key in the hole to the left of the cable, and turn counterclockwise to tighten to locking screw. Turn the hex key approximately 3 rotations, and check to see if it has locked. Try to turn the device to the left if the device is still loose please tighten the locking screw a few more rotations until the sensor is firmly locked in place

*Do not overtighten the locking screw as it may become dislodged and attached to the magnet wall plate making it difficult to remove the sensor.



Wall mount

- + Mount plate
- + Two screws

Materials not included

- + Level
- + Screwdriver
- + Optional cable management
- + Alcohol wipe
- + Microfiber cloth

Power & connectivity

All sensors require USB-C (included)

Step 1: Remove mount plate

Remove device from box.

Turn the attached mount plate counter-clockwise to remove mount from sensor. The plate will twist off, do not pull until unlocked from magnets.

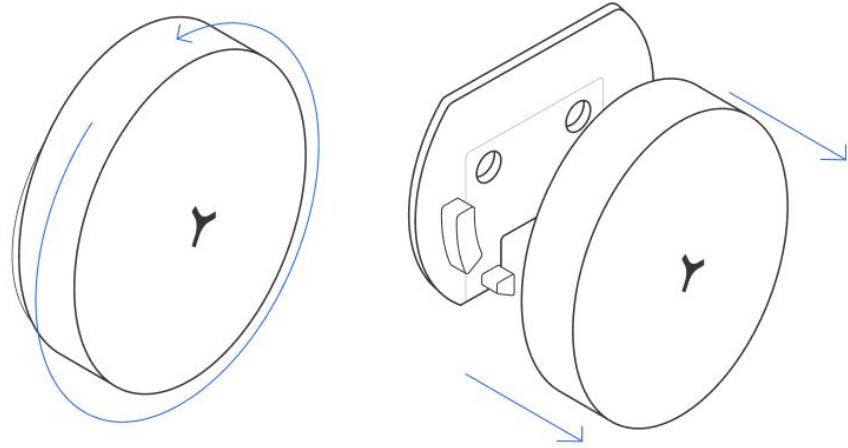

Step 2: Identify installation location

Follow these guidelines for optimal sensor location:

- + **Power Requirement:** The Waffle must be powered via USB-C. A 6-foot cable is included for U.S. customers.
- + **Clear Field of View:** Ensure no objects are placed directly in front of the Waffle unit, as this will obstruct its field of view.
- + **Proper Orientation:** The Waffle's LED and cable should always be positioned at the bottom.
- + **Sensor Height:** The Waffle should be installed at a height between 42"-60". We recommend being at least 12" above the top of the table or desk in the room.
- + **Sensor Location on Wall:** The Waffle should be installed as close to the center of the wall

Step 3: Screw on mount plate

Ensure mounting plate is level. Using a Phillips head screwdriver, screw both screws into the wall.

Note: Do not attach your Waffle sensor at this point

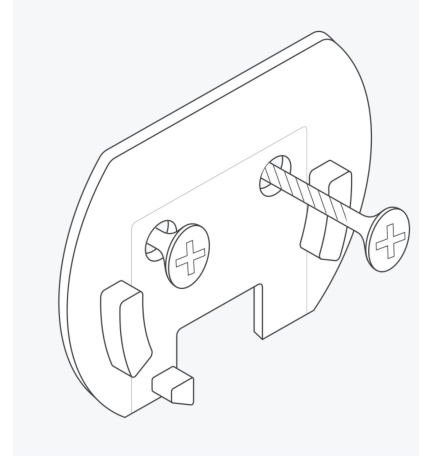
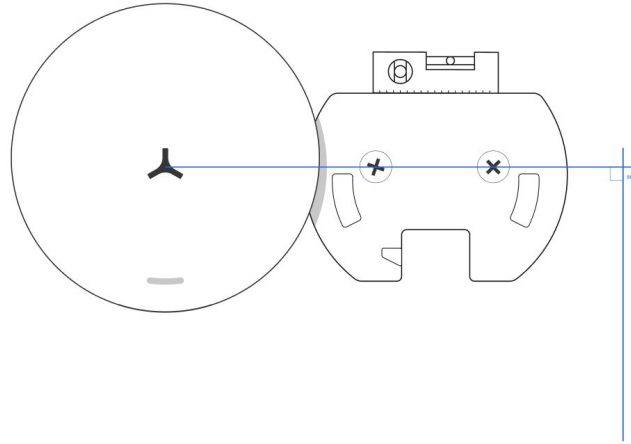

Step 4: Identify the sensor in the Density Spaces app

Download the Density Spaces app in the App Store (iOS only) or via mobile.density.io.

Before placing the Waffle back onto the mount plate, open the app, and scan the QR code on the back of the sensor.

If you've already placed the sensor on the mount plate, use the QR code on the back of the box or manually enter this Waffle's serial number.

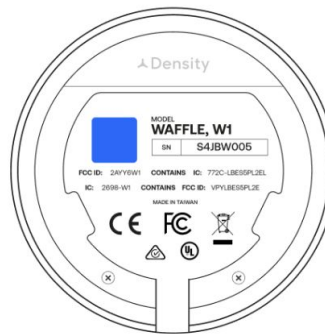

Step 5: Insert USB-C

Insert the USB-C into the Waffle device until you hear a click.

Optional: Insert USB-C locking clip

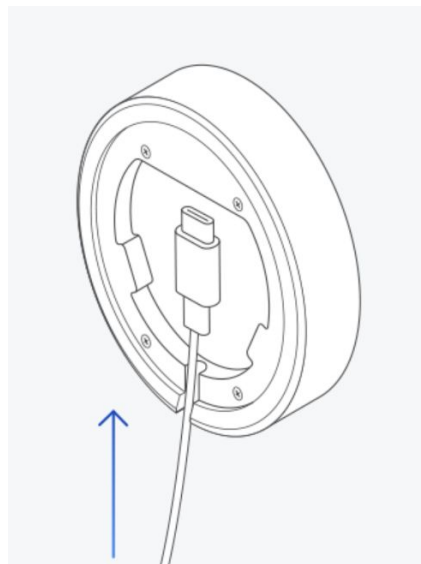

Step 6: Attach Waffle to mount

Hold the waffle at 10 o'clock position and when you feel the magnets activate, twist clockwise to lock into mount.

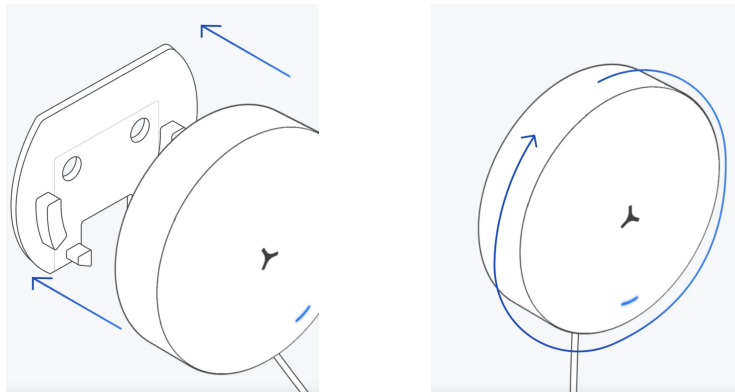

Step 7: Plug in sensor

Plug in the wall adapter to the cable and power supply. The LED light will turn blue to show it receiving power, and is ready to begin provisioning in the setup appy.

Please note: do not plug in the sensor until you are ready to use the setup app. The bluetooth connection will time out at 5 minutes.

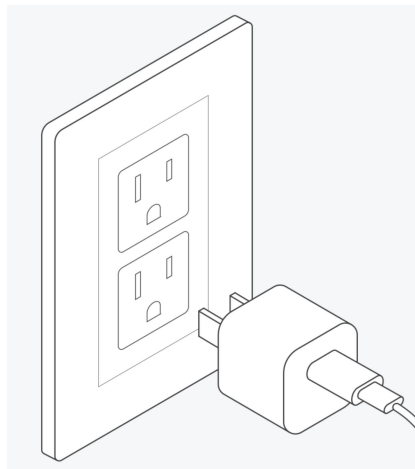

Step 8: Complete setup in the app

Follow the setup instructions in the Density Spaces app. The Density Spaces app is available in the Apple App Store, or at mobile.density.io.

If you have not completed WiFi setup within five minutes, Bluetooth will disconnect and the LED will turn from blue to red. Please unplug Waffle and plug it back in to reactivate Bluetooth. You'll see the LED turn blue.

When the LED turns white, you have successfully set up your Waffle.

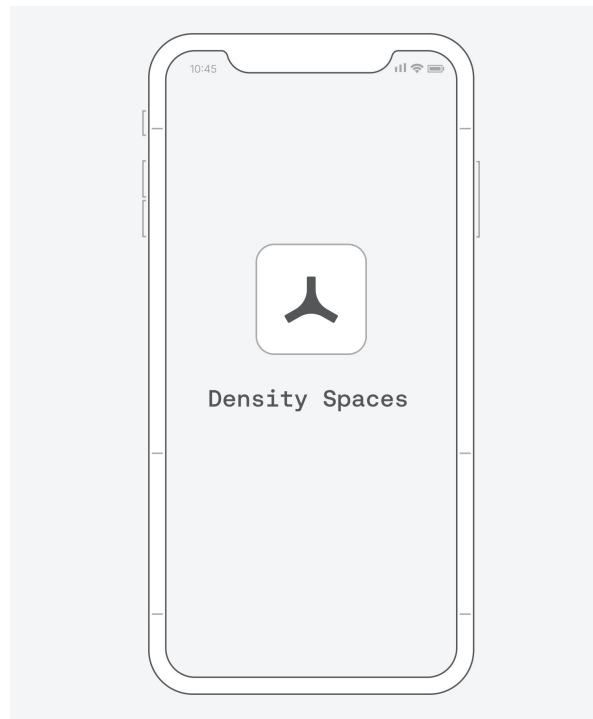

Optional: Tighten the locking screw

Place the provided hex key in the hole to the left of the cable, and turn counterclockwise to tighten to locking screw. Turn the hex key approximately 3 rotations, and check to see if the device has locked.

*The hex key does not need to be held straight, you can twist at an angle for a full rotation.



Under mount

- + Mount plate
- + TV mount
- + Adhesive strips

Materials not included

- + Level
- + Optional cable management
- + Alcohol wipe
- + Microfiber cloth

Power & connectivity

All sensors require USB-C (included)

Step 1: Identify the sensor in the Density Spaces app

Download the Density Spaces app in the App Store (iOS only) or via mobile.density.io.

Before placing the Waffle back onto the mount plate, open the app, and scan the QR code on the back of the sensor.

If you've already placed the sensor on the mount plate, use the QR code on the back of the box or manually enter this Waffle's serial number.

Step 2: Remove wall mount plate from Waffle

Remove device from box.

Turn the attached mount plate counter-clockwise to remove mount from sensor. The plate will twist off, do not pull until unlocked from magnets.

Set aside the wall mount plate from the Waffle. It is not needed with the under mount.

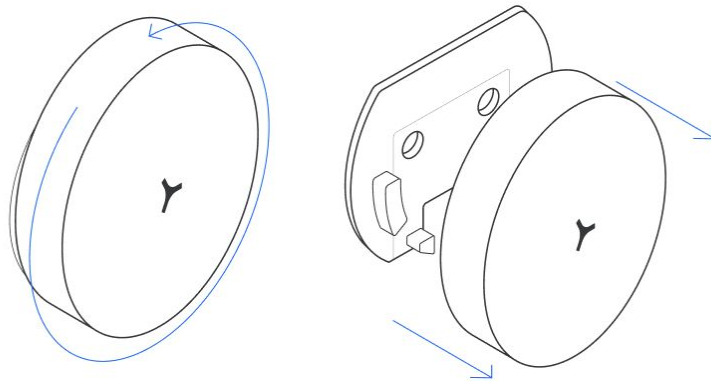

Step 3: Thread cable and plug USB-C into Waffle

Thread USB-C cable through the under mount.

Insert the USB-C into the Waffle device until you hear a click.

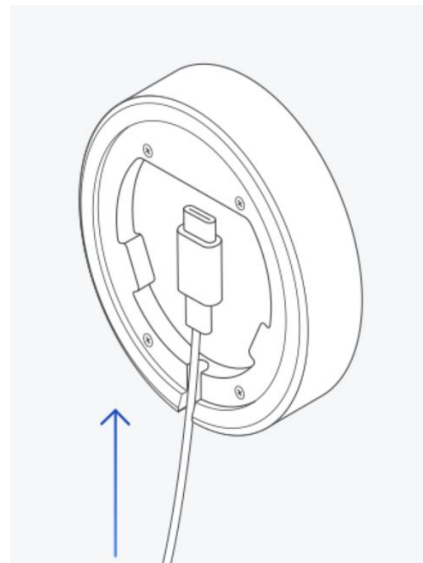

Step 4: Attach Waffle to Under Mount

Hold the waffle at 10 o'clock position and when you feel the magnets activate, twist clockwise to lock into mount.

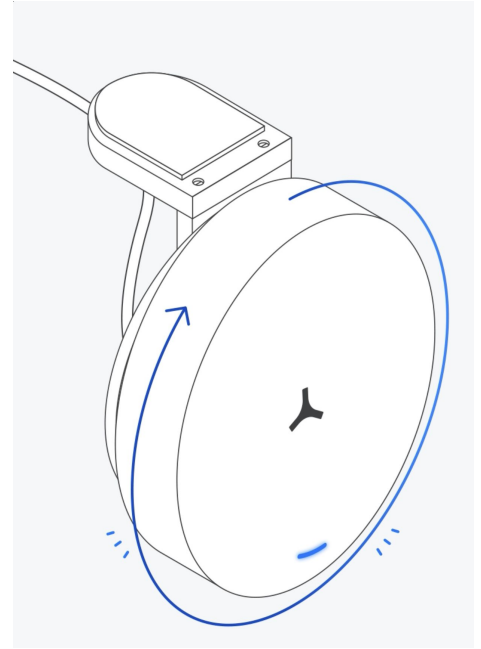
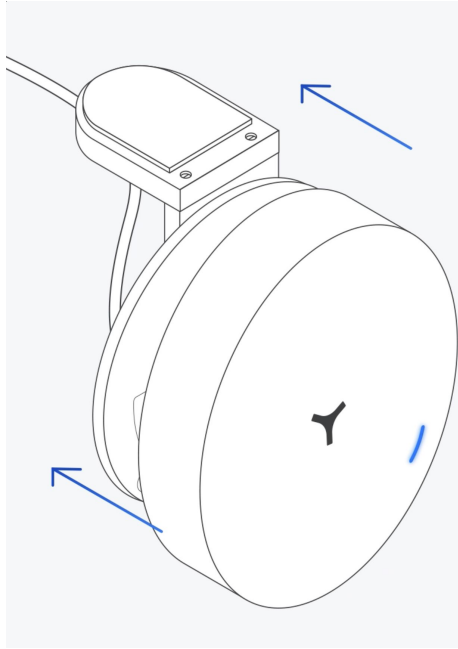

Step 5: Identify installation location

Follow these guidelines for optimal sensor location:

- + **Power Requirement:** The Waffle must be powered via USB-C. A 6-foot cable is included for U.S. customers.
- + **Clear Field of View:** Ensure no objects are placed directly in front of the Waffle unit, as this will obstruct its field of view.
- + **Proper Orientation:** The Waffle's LED and cable should always be positioned at the bottom.
- + **Attaching to a Desk:** Install towards the back of the desk in the left or right corner, facing the chair at a 45 degree angle, where someone is unlikely to knock the sensor.
- + **Attaching to a TV/Monitor:** Find a 1"x1" flat location on the bottom edge of the TV/Monitor.

Step 6: Clean installation location

Clean the mount location with an alcohol wipe and dry with microfiber cloth.

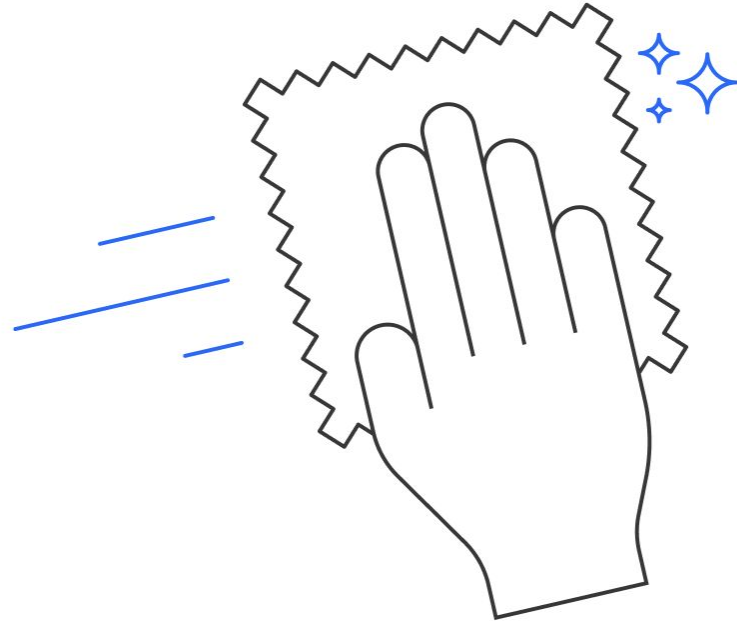

Step 7: Attach to installation location

Remove the liner and attach to the clean location under the TV or desk. Press and hold for 15 seconds.

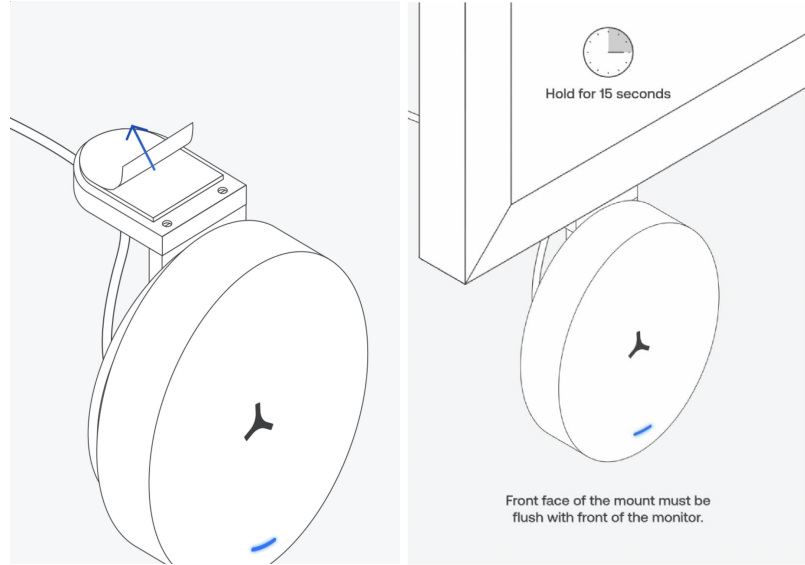

Step 8: Plug in sensor

Plug in the wall adapter to the cable and power supply. The LED light will turn blue to show it receiving power, and is ready to begin provisioning in the setup app.

Please note: do not plug in the sensor until you are ready to use the setup app. The bluetooth connection will time out at 5 minutes.

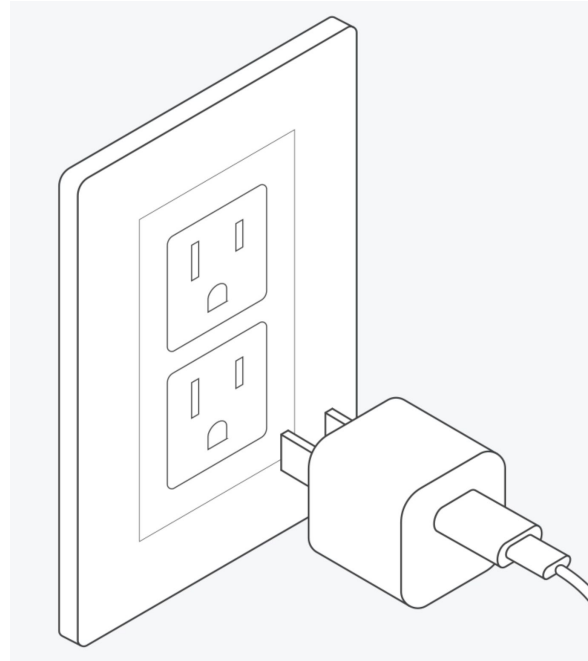

Step 9: Complete setup in the app

Follow the setup instructions in the Density Spaces app. The Density Spaces app is available in the Apple App Store, or at mobile.density.io.

If you have not completed WiFi setup within five minutes, Bluetooth will disconnect and the LED will turn from blue to red. Please unplug Waffle and plug it back in to reactivate Bluetooth. You'll see the LED turn blue.

When the LED turns white, you have successfully set up your Waffle.

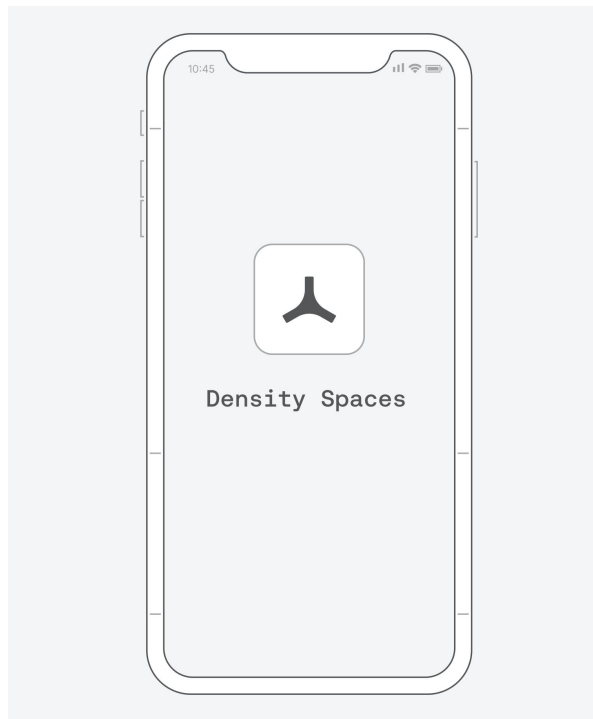

Table Top Stand

- + Mount plate
- + Stand mount
- + Adhesive strips

Materials not included

- + Optional cable management
- + Alcohol wipe
- + Microfiber cloth

Power & connectivity

All sensors require USB-C (included)

Step 1: Remove mount plate

Remove device from box.

Turn the attached mount plate counter-clockwise to remove mount from sensor. The plate will twist off, do not pull until unlocked from magnets.

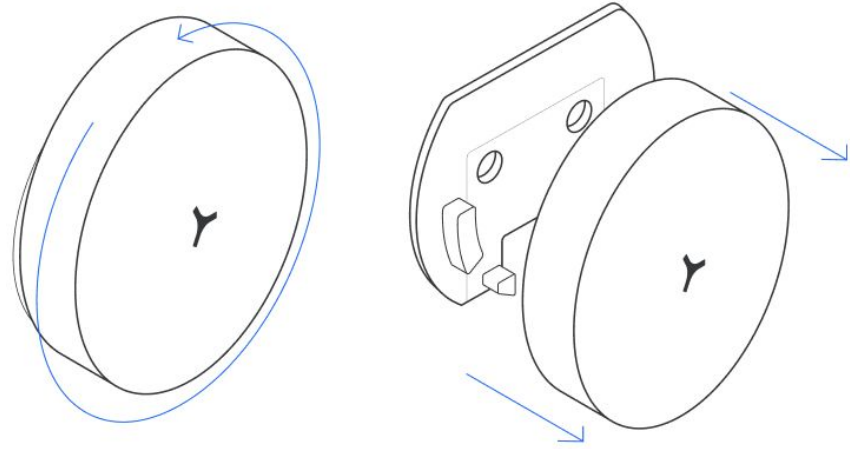

Step 2: Identify installation location

Identify your placement location with these guidelines:

- Within 6 feet of an outlet
- Placed at the edge of the surface you are placing it (table, desk, bookshelf, etc.)
- Place the sensor towards the top of the shelf so that it is installed at a height between 3.5 feet and 5 feet. We recommend installing at least one foot above the top of the table or desk in the room.

Please note: The stand should not be installed at the same height as the table/desk it is measuring. Waffle works best when placed a foot above the table height.

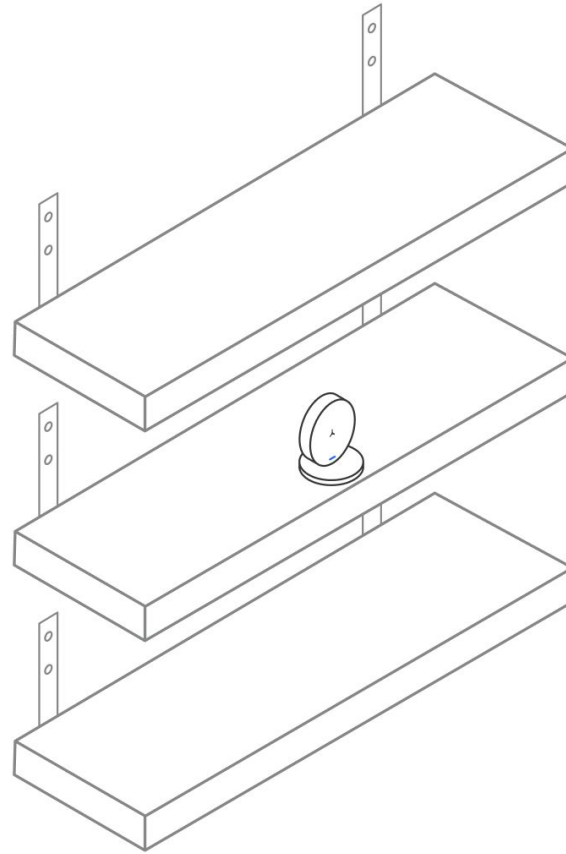

Step 4: Identify the sensor in the Density Spaces app

Download the Density Spaces app in the App Store (iOS only) or via mobile.density.io.

Before placing the Waffle back onto the mount plate, open the app, and scan the QR code on the back of the sensor.

If you've already placed the sensor on the mount plate, use the QR code on the back of the box or manually enter this Waffle's serial number.

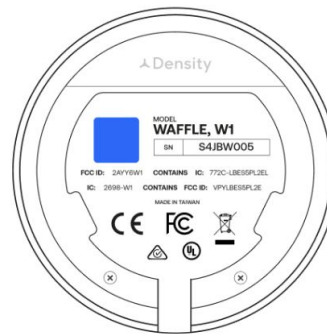

Step 5: Insert USB-C

Thread USB-C cable through the hole. Insert the USB-C into the Waffle device until you hear a click.

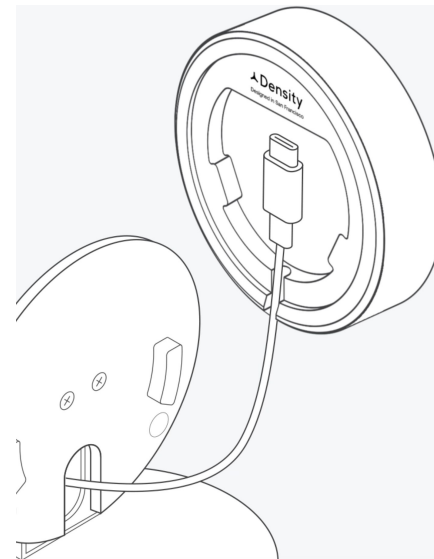
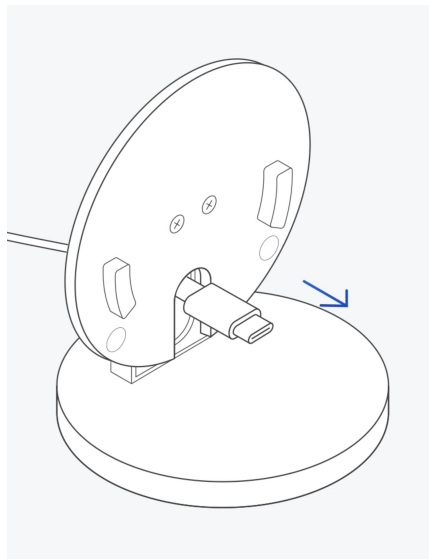

Step 6: Attach Waffle to mount

Hold the waffle at 10 o'clock position and when you feel the magnets activate, twist clockwise to lock into mount.

Loop the power cord / USB C cable up through optional cable management hook.

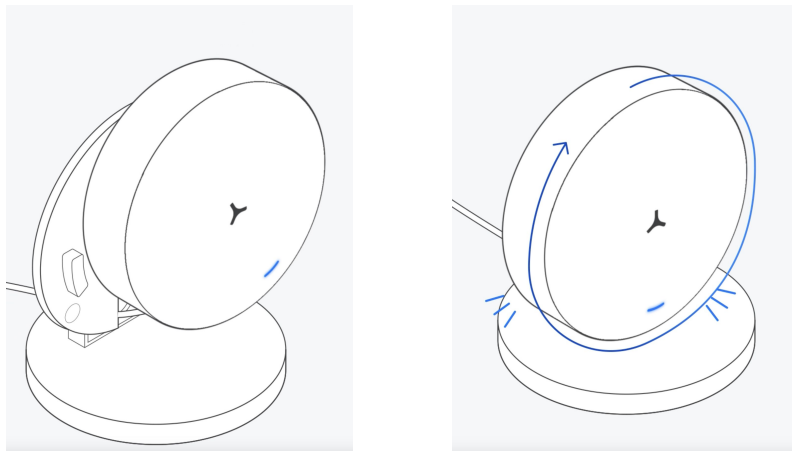

Step 7: Plug in sensor

Plug in the wall adapter to the cable and power supply. The LED light will turn blue to show it receiving power, and is ready to begin provisioning in the setup app.

Please note: do not plug in the sensor until you are ready to use the setup app. The bluetooth connection will time out at 5 minutes.

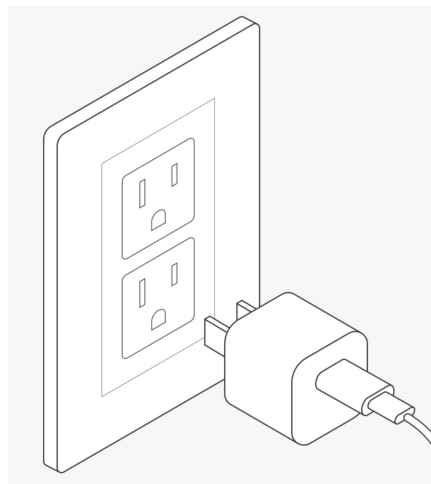

Step 8: Attach to installation location (optional)

Remove the liner and attach to the clean location.
Press and hold for 15 seconds.

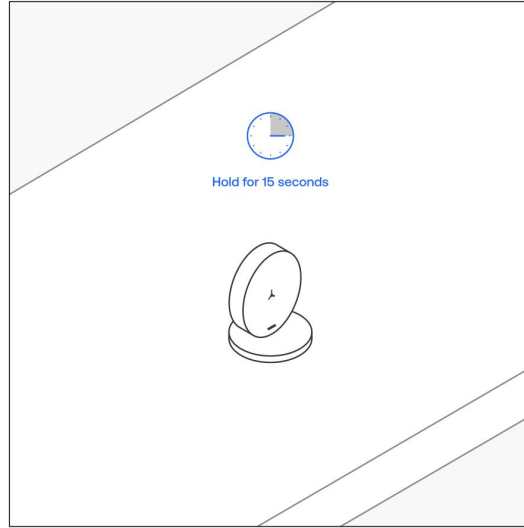

Step 9: Complete setup in the app

Follow the setup instructions in the Density Spaces app. The Density Spaces app is available in the Apple App Store, or at mobile.density.io.

If you have not completed WiFi setup within five minutes, Bluetooth will disconnect and the LED will turn from blue to red. Please unplug Waffle and plug it back in to reactivate Bluetooth. You'll see the LED turn blue.

When the LED turns white, you have successfully set up your Waffle.

