

Networking and Power

Entry Sensor Version s5b (lid with ceiling mount threads)

01 — Power

02 — Networking

Power Requirements

Density sensors require 802.3at PoE+ (Power over Ethernet) and need a constant 30W power budget.

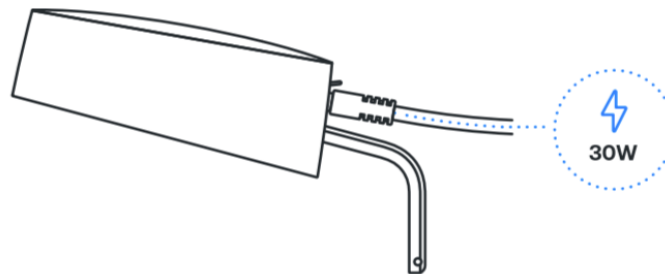

Cabling Requirements

The sensor requires a Cat 5e or later ethernet cable. (not included)

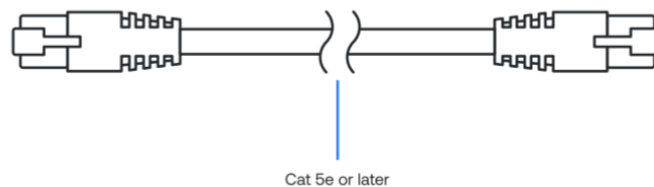

Option 1 - PoE+ Switch

Connect one end of a Cat 5e or later ethernet cable to a 802.3at (PoE+ Type 2) compliant network switch capable of providing 30W per port. Plug the other end of the ethernet cable into the sensor.

Each sensor requires 30W at the PSE (Power 30W Supply Equipment / Switch) per 802.3at PoE+ Per Port Type 2 spec. Please ensure your switch is not overloaded or the sensor will fail to operate. (For example, if you have a 24-port 500W switch you can support up to 16 sensors at a time assuming no other load on the remaining ports).

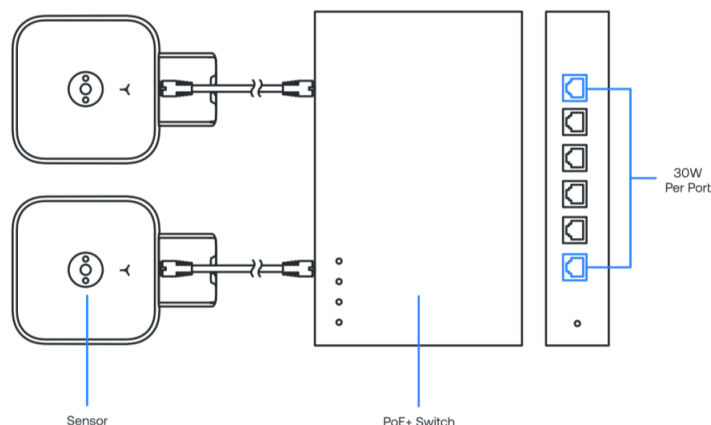

Option 2 - PoE+ Injector Using WiFi

Plug the 30W PoE+ Injector into any standard 120v wall outlet. Plug one end of a Cat 5e or later ethernet cable into the *Data & Power Out* port located on the bottom of the injector. Plug the other end of the ethernet cable into the sensor. Use the Unit Setup App to connect the sensor to a WiFi network.

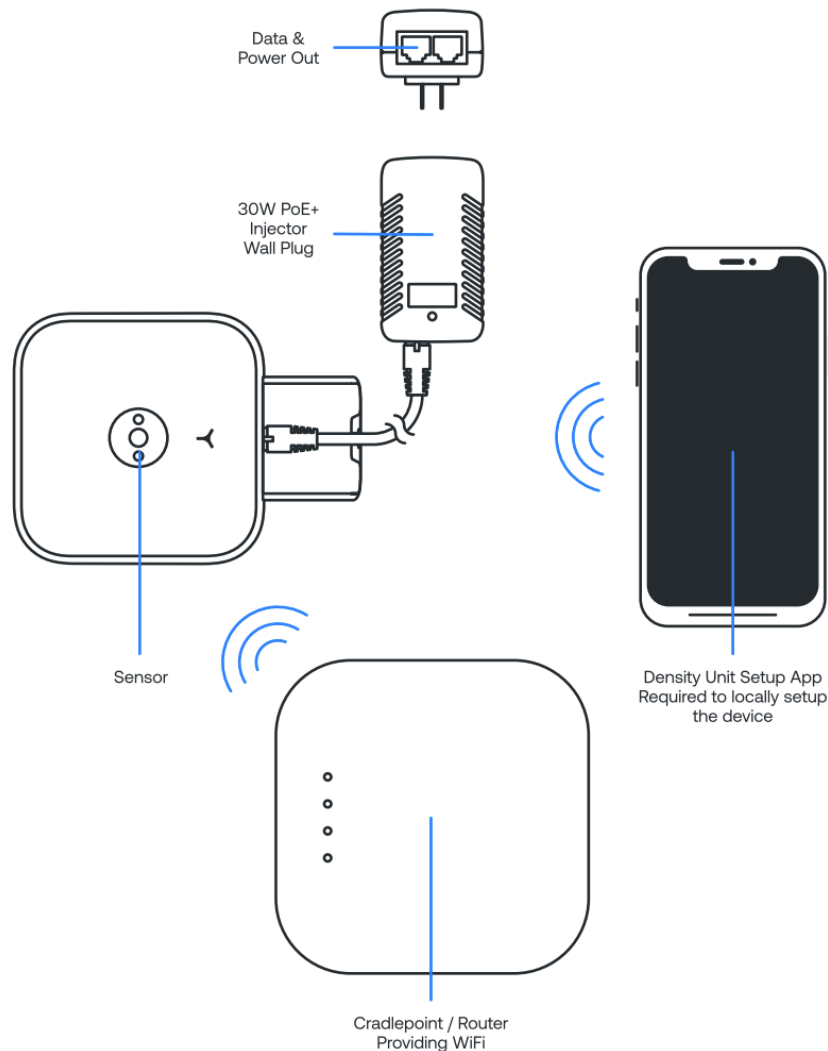

Option 3 - PoE+ Injector Using Ethernet

Plug the 30W PoE+ Injector into any standard 120v wall outlet. Plug one end of a Cat 5e or later ethernet cable into a cradlepoint / router or non PoE+ switch. Plug the other end of the cable into the Data In port located on the bottom of the Injector. Plug an additional ethernet cable into the Data & Power Out port also located on the bottom of the injector. Plug the other end of the ethernet cable into the sensor.

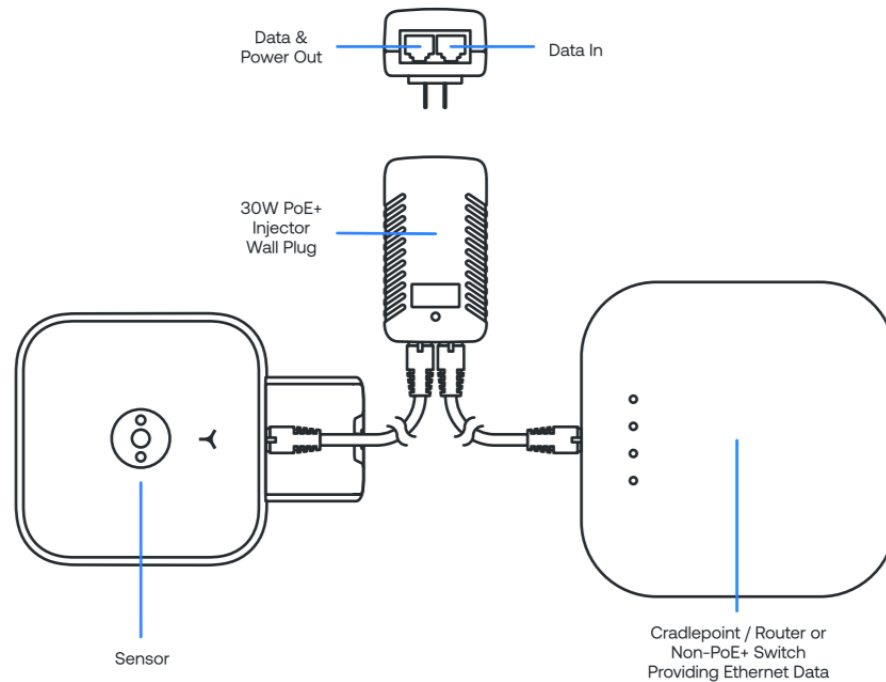

Networking

02

Networking Basics

Density devices require internet connectivity to pass data to the web application.

Options to connect your Density devices to the internet:

- Option 1 - Wired internet via switch
- Option 2 - Wi-Fi (requires the Density Unit Setup App to locally set up the device)
- Option 3 - Wired internet via cradle-point

Networks that are not supported:

- Captive portal
- Proxy
- 5GHz Wifi networks
- WPA2 Enterprise
- Hidden Networks*

* Hidden networks can be used if temporarily made transparent while we configure the devices.

Network Configuration Options

Both DHCP and Static IP configurations are supported. (Static IP configurations require the Density Unit Setup App to locally set up the device).

DHCP Supported Configuration Options

Option 53 - DHCP Message Type

- Discover

Option 57 - Maximum DHCP Message Size

- 576

Option 55 - Parameter List

- Parameter request Line Items
 - Subnet Mask (1)
 - Router (3)
 - Interface MTU (26)
 - Private/Proxy Auto Discovery (252)
 - Network Time Protocol Servers (42)
 - Domain Name (15)
 - Domain Name Server (6)
 - Hostname (12)

Option 60 - Vendor Class Identifier

- Density S5 DPU

Option 61 - Client Identifier

- MAC Address

Option 12 - Hostname

- Density-<Serial>

Static Configuration Requirements

You will need an IPv4 Address and Name Servers from your IT team to use in the setup process. [\(Requires the Density Unit Setup App to locally set up the device\).](#)

If You Have a Corporate Firewall

You will need to whitelist the device MAC addresses (the MAC addresses can be found on the outside of the packaging box for the device). You may also have to whitelist the following addresses to ensure the device is able to communicate to your corporate network:*.density.io

- *.s3.amazonaws.com
- *.pool.ntp.org (if applicable)
- connman.net
- connectivitycheck.gstatic.com
- 8.8.8.8 (if applicable)
- 8.8.4.4 (if applicable)

Density does not currently support IP address whitelisting. A list of exact API subdomains is available by request.

Notes:

- The DPUs communicate via https, therefore port 443 must be open
 - ntp port (port 123) must be open
 - If internal DNS is not available then external dns servers 8.8.8.8 and 8.8.4.4 will be used and port 53 must be open
-

Unit Setup App

Used to configure units. iOS and Android application available - Go to mobile.density.io to download.